

2010 National Building Code of Canada (NBC)

# 2013 Revisions and Errata Package for First Printing

Selected replacement pages have been produced for the NBC.

Please print and insert in your copy of the Code.



# Revisions and Errata

## Issued by the Canadian Commission on Building and Fire Codes

The Change History table that follows describes revisions, errata and editorial updates that apply to the National Building Code of Canada 2010:

- Revisions are changes deemed urgent that have been approved by the Canadian Commission on Building and Fire Codes.
- Errata are corrections to existing text.
- Editorial updates are provided for information purposes only.

Code pages containing revisions and/or errata are identified with the words “Amended Page” in the footer; pages with editorial updates and index pages with changes are not flagged.

Contact your local authority having jurisdiction to find out if these revisions and errata apply in your province or territory.

### Change History — National Building Code of Canada 2010

Division	Code Reference	Change	Date (Y-M-D)	Description of Change
Preface	n/a	editorial update	2012-12-21	Text referring to application statements was deleted as these statements are no longer being published
A	1.4.2.1.(1)	editorial update	2012-12-21	The following abbreviations were added to the list as a result of the addition of new Section 9.36.: HDD, HVAC, K, R, RSI and U-value
A	1.5.1.1.(1)	revision	2012-12-21	Sentence was revised to read “Except as provided in Sentence (2), the provisions ...”
A	1.5.1.1.(2)	revision	2012-12-21	Sentence was added
A	2.1.1.2.	revision	2012-12-21	Reference to Appendix Note was added following Article title
A	2.1.1.2.(1)	revision	2012-12-21	Sentence was revised to read “Except as provided in Sentences (2) to (6), ...”
A	2.1.1.2.(6)	revision	2012-12-21	Sentence was added
A	2.2.1.1.(1)	revision	2012-12-21	Objective OE, Environment, and sub-objectives OE1, Resources, and OE1.1, excessive use of energy, were added
A	3.1.1.2.(1)	revision	2012-12-21	Sentence was revised to read “Except as provided in Sentences (2) to (4), ...”
A	3.1.1.2.(4)	revision	2012-12-21	Sentence was added
A	3.2.1.1.(1)	revision	2012-12-21	Functional Statements F90–F93, F95, F96 and F98–F100 were added
A	A-2.1.1.2.(6)	revision	2012-12-21	Appendix Note was added
A	A-2.2.1.1.(1)	revision	2012-12-21	Reference to the National Energy Code for Buildings was added
A	A-3.2.1.1.(1)	revision	2012-12-21	Reference to the National Energy Code for Buildings was added
B	1.3.1.1.(1)	revision	2013-10-31	Date stated in Sentence was revised to read “30 June 2012”
B	Table 1.3.1.2.	revision	2012-12-21	Standards referenced in new Section 9.36. were added
B	Table 1.3.1.2.	revision	2012-12-21	ASTM F 1667-05 was added as a result of revisions to Sentences 9.23.3.1.(1), 9.26.2.2.(1) and 9.29.5.6.(1)
B	Table 1.3.1.2.	revision	2013-10-31	Document references were updated as applicable to reflect more recent editions published as of June 30, 2012

## Change History — National Building Code of Canada 2010 (Continued)

Division	Code Reference	Change	Date (Y-M-D)	Description of Change
B	1.3.2.1.(1)	editorial update	2012-12-21	The following abbreviations and applicable addresses were added as a result of new Section 9.36.: AHAM, AHRI, CTI, DOE, ICC, NECB and NFRC; the address for TPIC was updated
B	3.2.3.4.(1)	erratum	2012-12-21	Change bar was added
B	3.2.4.22.(10)	erratum	2012-12-21	Sentence was corrected to read "... required by Sentence (7) .."
B	3.4.7.7.(1)	erratum	2012-12-21	Sentence was corrected to read "... Articles 3.4.6.3. and 3.4.6.4."
B	4.1.7.1.(5)	erratum	2012-12-21	Clause (b) was corrected to read "... or 20 times the height of the <i>building</i> , whichever is greater ..." Clause (c) was corrected to read "... or 20 times the height of the <i>building</i> from a change in terrain conditions ..."
B	5.2.2.1.(2)	revision	2012-12-21	Sentence was revised to read "... Except as provided in Article 4.1.8.18., the structural loads ..."
B	5.10.1.1.(1)	erratum	2012-12-21	Sentence was corrected to read "... Except as provided in Sentence (2) and elsewhere in this Part, ..."
B	6.2.1.4.(1)	erratum	2013-10-31	Word "and" at the end of Clause (e) was replaced with "or"
B	6.2.2.1.(3)	erratum	2012-12-21	Sentence was modified to clarify intent
B	6.2.2.6.(1)	erratum	2013-10-31	Sentence was corrected to read "Except as provided in Subsection 6.2.12., systems ..."
B	6.2.4.1.(4)	erratum	2012-12-21	Change bar was added
B	Table 6.4.1.1.	erratum	2012-12-21	Functional Statement F43 was deleted from attribution for Sentence 6.2.1.7.(2)
B	8.2.1.3.(1)	erratum	2012-12-21	Sentence was corrected to read "... and is located 2 m or more from a <i>public way</i> , ..."
B	9.4.1.1.(2)	erratum	2013-10-31	Sentence was corrected to read "... on the floor according to Table 4.1.5.3. shall not exceed 2.4 kPa."
B	9.4.2.1.(1)	erratum	2013-10-31	Text "(See Appendix A.)" was moved from the end of the Sentence to following title of Article 9.4.2.2.
B	9.7.2.2.	revision	2012-12-21	Sentences (1) to (9) were reordered and Sentence (10) was added
B	9.10.9.7.(2)	erratum	2012-12-21	Term "firestop system" was replaced with defined term " <i>fire stop</i> "
B	9.10.14.5.(3)	erratum	2012-12-21	Word "and" at the end of the Clause (b) was deleted Subclause (e)(i) was corrected to read "... conforms to Subsection 9.27.12.,"
B	9.10.15.5.(2)	erratum	2012-12-21	Subclause (b)(i) was corrected to read "... conform to Subsection 9.27.12.,"
B	9.12.2.2.(1)	erratum	2012-12-21	Sentence was corrected to read "... Except as provided in Sentences (4) to (7), ..."
B	9.19.2.1.(1)	revision	2012-12-21	Sentence was revised
B	9.23.3.1.	revision	2012-12-21	Sentence (1) was revised Sentence (2) was added
B	9.23.6.1.(3)	erratum	2013-10-31	Sentence was corrected to read "... greater than 0.70 but not greater than 1.2 or the 1-in-50 hourly ..."
B	9.23.13.7.(7)	erratum	2012-12-21	Sentence was corrected to read "... the ratio of the length of <i>braced wall panels</i> in the respective upper <i>braced wall bands</i> to the length of <i>braced wall panels</i> in the reduced exterior <i>braced wall band</i> ..."
B	9.23.16.5.(2)	erratum	2013-10-31	Word "and" at the end of Clause (a) was replaced with "or"
B	9.25.1.1.(2)	revision	2012-12-21	Subclause (a)(i) was revised to read "thermal insulation conforming to Subsection 9.25.2. and Section 9.36.," Subclause (a)(ii) was revised to read "an air barrier conforming to Subsection 9.25.3. and Section 9.36.,"
B	9.25.1.1.(3)	revision	2012-12-21	Sentence was revised to read "... Sections 9.32., 9.33. and 9.36."
B	9.25.5.1.(1)	erratum	2012-12-21	Word "and" was added at the end of Subclause (a)(i)
B	9.26.2.2.(1)	revision	2012-12-21	Clause (b) was added
B	9.29.5.6.(1)	revision	2012-12-21	Clause (b) was added
B	9.31.1.1.(4)	revision	2012-12-21	Sentence was added
B	9.32.1.1.(4)	revision	2012-12-21	Sentence was added

### Change History — National Building Code of Canada 2010 (Continued)

Division	Code Reference	Change	Date (Y-M-D)	Description of Change
B	9.32.3.1.(1)	erratum	2012-12-21	Clause (c) was added to clarify intent
B	9.32.3.11.(4)	revision	2012-12-21	Sentence was restructured and requirement was added as Clause (b)
B	9.33.1.1.(4)	revision	2012-12-21	Sentence was added
B	Section 9.36.	revision	2012-12-21	Section was added
B	Table 9.36.4.2.	erratum	2013-10-31	Table Note (1) was corrected to read “1 kW = 3412 Btu/h”
B	9.36.5.11.(15)	erratum	2013-10-31	Clause (b) was corrected to read “0.0251 for all other types of heating systems.”
B	9.36.5.15.(14)	erratum	2013-10-31	Clause (b) was corrected to read “0.0251 for all other types of heating systems.”
B	Table 9.37.1.1.	revision	2012-12-21	Attributions were added for new Sentence 9.23.3.1.(2) and new Section 9.36.
B	A-1.1.2.1.(1)	erratum	2012-12-21	Appendix Note was corrected to read “... at the end of Volume 1.”
B	Table A-1.3.1.2.(1)	revision	2012-12-21	Standards referenced in new Appendix Notes A-9.36.1.1.(1) to A-9.36.5.15.(8) were added
B	Table A-1.3.1.2.(1)	revision	2013-10-31	Document references were updated as applicable to reflect more recent editions published as of June 30, 2012
B	A-4.1.5.8.	erratum	2013-10-31	Text was corrected to read “... Commentary entitled Live Loads ...”
B	A-5.2.2.1.(2)(c)	revision	2012-12-21	Second paragraph was added
B	A-9.4.2.1.(1)	erratum	2013-10-31	Appendix Note number was corrected to read “A-9.4.2.2.”
B	A-9.8.8.6.(2)	erratum	2012-12-21	Offset shown in top guard protrusion in Figure A-9.8.8.6.(2)-B was corrected
B	A-9.10.15.4.(2)	erratum	2012-12-21	In Figure A-9.10.15.4.(2)-C, Table Notes on “required” and “noncombustible” were corrected for limiting distance <sub>2</sub> to limiting distance <sub>3</sub>
B	A-9.10.22.	erratum	2012-12-21	Word “range” was replaced with “cooktop” in title, text and Figure title
B	A-9.19.2.1.(1)	revision	2012-12-21	Appendix Note was added
B	A-9.23.3.1.(2)	revision	2012-12-21	Appendix Note was added
B	A-Table 9.23.4.3.	erratum	2013-10-31	Text in last two bullets was corrected as follows: <ul style="list-style-type: none"> <li>• live load: first floor = 1.9 kPa; second floor = 1.4 kPa</li> <li>• dead load = 1.5 kPa (0.5 kPa floor + 1.0 kPa partition)</li> </ul>
B	A-9.32.3.3.	erratum	2012-12-21	Word “range” was replaced with “cooktop” in third paragraph under section entitled “Indoor Air Exhaust”
B	A-9.32.3.3.(10)	erratum	2012-12-21	Appendix Note was corrected to read “... the use of a cooktop exhaust or hood fan ...”
B	A-9.36.1.1.(1) to A-9.36.5.15.(8)	revisions	2012-12-21	Eighty-four Appendix Notes were added
B	Table C-2	erratum	2012-12-21	Value for S <sub>a</sub> (2.0) for Sault Ste. Marie was corrected to read “0.012”
B	Table D-1.1.2.	revision	2013-10-31	Document references were updated as applicable to reflect more recent editions published as of June 30, 2012
C	2.2.8.	revision	2012-12-21	Subsection was added
C	A-2.2.8.1.(1)	revision	2012-12-21	Appendix Note was added
C	A-2.2.8.3.(2)(c)(i)	revision	2012-12-21	Appendix Note was added
Index	Letter A	erratum	2012-12-21	Entry under “Application of the National Building Code, factory-made buildings” was corrected to read “factory-constructed buildings”
Index	Letter F	erratum	2012-12-21	Entry for “Factory-made buildings” was corrected to read “Factory-constructed buildings” Under entry for “Fans,” “range-top” was corrected to read “cooktop” Entry for “Fire blocks” was added Entry for “Fire stopping” was corrected Entry for “Fire stops” was corrected
n/a	Conversion Factors	editorial update	2012-12-21	Factor to convert kW to Btu/h was added: 3.412
		erratum	2013-10-31	Factor to convert kW to Btu/h was corrected to read “3412”



# **Part 1 General**

## **Section 1.1. General**

### **1.1.1. Application**

#### **1.1.1.1. Application**

**1)** This Part applies to all *buildings* covered in this Code. (See Article 1.1.1.1. of Division A.)

### **1.1.2. Objectives and Functional Statements**

#### **1.1.2.1. Attributions to Acceptable Solutions**

**1)** For the purpose of compliance with this Code as required in Clause 1.2.1.1.(1)(b) of Division A, the objectives and functional statements attributed to the acceptable solutions in Division B shall be the objectives and functional statements identified in Sections 3.9., 4.5., 5.11., 6.4., 7.2., 8.3. and 9.37. (See Appendix A.)

### **1.1.3. Climatic and Seismic Data**

#### **1.1.3.1. Climatic and Seismic Values**

**1)** The climatic and seismic values required for the design of *buildings* under this Code shall be in conformance with the values established by the *authority having jurisdiction* or, in the absence of such data, with Sentence (2) and the climatic and seismic values in Appendix C. (See Appendix A.)

**2)** The outside winter design temperatures determined from Appendix C shall be those listed for the January 2.5% values. (See Appendix A.)

#### **1.1.3.2. Depth of Frost Penetration**

**1)** Depth of frost penetration shall be established on the basis of local experience.

### **1.1.4. Fire Safety Plan**

#### **1.1.4.1. Fire Safety Plan**

**1)** Where a fire safety plan is required, it shall conform to Section 2.8. of Division B of the NFC.

## **Section 1.2. Terms and Abbreviations**

### **1.2.1. Definitions of Words and Phrases**

#### **1.2.1.1. Non-defined Terms**

**1)** Words and phrases used in Division B that are not included in the list of definitions in Article 1.4.1.2. of Division A shall have the meanings that are commonly assigned to them in the context in which they are used, taking into account the

specialized use of terms by the various trades and professions to which the terminology applies.

**2)** Where objectives and functional statements are referred to in Division B, they shall be the objectives and functional statements described in Parts 2 and 3 of Division A.

**3)** Where acceptable solutions are referred to in Division B, they shall be the provisions stated in Parts 3 to 9.

### 1.2.1.2. Defined Terms

**1)** The words and terms in italics in Division B shall have the meanings assigned to them in Article 1.4.1.2. of Division A.

## 1.2.2. Symbols and Other Abbreviations

### 1.2.2.1. Symbols and Other Abbreviations

**1)** The symbols and other abbreviations in Division B shall have the meanings assigned to them in Article 1.4.2.1. of Division A and Article 1.3.2.1.

## Section 1.3. Referenced Documents and Organizations

### 1.3.1. Referenced Documents

#### 1.3.1.1. Effective Date

**1)** Unless otherwise specified herein, the documents referenced in this Code shall include all amendments, revisions, reaffirmations, reapprovals, addenda and supplements effective to 30 June 2012.

#### 1.3.1.2. Applicable Editions

**1)** Where documents are referenced in this Code, they shall be the editions designated in Table 1.3.1.2. (See Appendix A.)

**Table 1.3.1.2.**  
Documents Referenced in the National Building Code of Canada 2010  
Forming Part of Sentence 1.3.1.2.(1)

Issuing Agency	Document Number <sup>(1)(2)</sup>	Title of Document <sup>(3)</sup>	Code Reference
AHAM	ANSI/AHAM RAC-1-1982	Room Air Conditioners	Table 9.36.3.10.
AHRI	ANSI/AHRI 210/240-2008	Performance Rating of Unitary Air-Conditioning and Air-Source Heat Pump Equipment	Table 9.36.3.10.
AHRI	ANSI/AHRI 1060-2005	Performance Rating of Air-to-Air Exchangers for Energy Recovery Ventilation	9.36.3.8.(4)
AHRI	BTS-2000	Efficiency of Commercial Space Heating Boilers	Table 9.36.3.10.
AISI	S201-07	North American Standard for Cold-Formed Steel Framing - Product Data	9.24.1.2.(1)
ANSI	A208.1-2009	Particleboard	Table 5.10.1.1. 9.23.15.2.(3) 9.29.9.1.(1) 9.30.2.2.(1)
ANSI/CSA	ANSI Z21.10.3-2004/CSA 4.3-04	Gas Water Heaters – Volume III, Storage Water Heaters With Input Ratings Above 75,000 Btu Per Hour, Circulating and Instantaneous	Table 9.36.4.2.
ANSI/CSA	ANSI Z21.56-2006/CSA 4.7-2006	Gas-Fired Pool Heaters	Table 9.36.4.2.



**Table 1.3.1.2. (Continued)**

Issuing Agency	Document Number <sup>(1)(2)</sup>	Title of Document <sup>(3)</sup>	Code Reference
ANSI/CSA	ANSI Z83.8-2006/CSA 2.6-2006	Gas Unit Heaters, Gas Packaged Heaters, Gas Utility Heaters and Gas-Fired Duct Furnaces	Table 9.36.3.10.
ASHRAE	ANSI/ASHRAE 62-2001	Ventilation for Acceptable Indoor Air Quality (except Addendum n)	6.2.2.1.(2)
ASHRAE	ANSI/ASHRAE 103-2007	Annual Fuel Utilization Efficiency of Residential Central Furnaces and Boilers	Table 9.36.3.10.
ASHRAE	ANSI/ASHRAE 140-2007	Evaluation of Building Energy Analysis Computer Programs	9.36.5.4.(8)
ASME	B18.6.1-1981	Wood Screws (Inch Series)	Table 5.10.1.1. 9.23.3.1.(3)
ASME/CSA	ASME A17.1-2010/CSA B44-10	Safety Code for Elevators and Escalators	3.2.6.7.(2) 3.5.2.1.(1) 3.5.2.1.(2) 3.5.2.1.(3) 3.5.4.2.(1) Table 4.1.5.11.
ASTM	A 123/A 123M-09	Zinc (Hot-Dip Galvanized) Coatings on Iron and Steel Products	Table 5.10.1.1. Table 9.20.16.1.
ASTM	A 153/A 153M-09	Zinc Coating (Hot-Dip) on Iron and Steel Hardware	Table 5.10.1.1. Table 9.20.16.1.
ASTM	A 252-10	Welded and Seamless Steel Pipe Piles	4.2.3.8.(1)
ASTM	A 283/A 283M-03	Low and Intermediate Tensile Strength Carbon Steel Plates	4.2.3.8.(1)
ASTM	A 653/A 653M-11	Steel Sheet, Zinc-Coated (Galvanized) or Zinc-Iron Alloy-Coated (Galvannealed) by the Hot-Dip Process	Table 5.10.1.1. 9.3.3.2.(1)
ASTM	A 792/A 792M-10	Steel Sheet, 55% Aluminum-Zinc Alloy-Coated by the Hot-Dip Process	9.3.3.2.(1)
ASTM	A 1008/A 1008M-11	Steel, Sheet, Cold-Rolled, Carbon, Structural, High-Strength Low-Alloy, High-Strength Low-Alloy with Improved Formability, Solution Hardened, and Bake Hardenable	4.2.3.8.(1)
ASTM	A 1011/A 1011M-10	Steel, Sheet and Strip, Hot-Rolled, Carbon, Structural, High-Strength Low-Alloy, High-Strength Low-Alloy with Improved Formability, and Ultra-High Strength	4.2.3.8.(1)
ASTM	C 4-04	Clay Drain Tile and Perforated Clay Drain Tile	Table 5.10.1.1. 9.14.3.1.(1)
ASTM	C 27-98	Fireclay and High-Alumina Refractory Brick	9.21.3.4.(1)
ASTM	C 73-10	Calcium Silicate Brick (Sand-Lime Brick)	Table 5.10.1.1. 9.20.2.1.(1)
ASTM	C 126-11	Ceramic Glazed Structural Clay Facing Tile, Facing Brick, and Solid Masonry Units	Table 5.10.1.1. 9.20.2.1.(1)
ASTM	C 177-10	Steady-State Heat Flux Measurements and Thermal Transmission Properties by Means of the Guarded-Hot-Plate Apparatus	9.36.2.2.(1)
ASTM	C 212-10	Structural Clay Facing Tile	Table 5.10.1.1. 9.20.2.1.(1)
ASTM	C 260/C 260M-10a	Air-Entraining Admixtures for Concrete	9.3.1.8.(1)
ASTM	C 411-11	Hot-Surface Performance of High-Temperature Thermal Insulation	3.6.5.4.(4) 3.6.5.5.(1) 9.33.6.4.(4) 9.33.8.2.(2)
ASTM	C 412M-11	Concrete Drain Tile (Metric)	Table 5.10.1.1. 9.14.3.1.(1)
ASTM	C 444M-03	Perforated Concrete Pipe (Metric)	Table 5.10.1.1. 9.14.3.1.(1)
ASTM	C 494/C 494M-11	Chemical Admixtures for Concrete	9.3.1.8.(1)

Table 1.3.1.2. (Continued)

Issuing Agency	Document Number <sup>(1)(2)</sup>	Title of Document <sup>(3)</sup>	Code Reference
ASTM	C 518-10	Steady-State Thermal Transmission Properties by Means of the Heat Flow Meter Apparatus	9.36.2.2.(1)
ASTM	C 553-11	Mineral Fiber Blanket Thermal Insulation for Commercial and Industrial Applications	Table 5.10.1.1.
ASTM	C 612-10	Mineral Fiber Block and Board Thermal Insulation	Table 5.10.1.1.
ASTM	C 700-11	Vitrified Clay Pipe, Extra Strength, Standard Strength and Perforated	Table 5.10.1.1. 9.14.3.1.(1)
ASTM	C 834-10	Latex Sealants	Table 5.10.1.1. 9.27.4.2.(2)
ASTM	C 920-11	Elastomeric Joint Sealants	Table 5.10.1.1. 9.27.4.2.(2)
ASTM	C 954-11	Steel Drill Screws for the Application of Gypsum Panel Products or Metal Plaster Bases to Steel Studs from 0.033 in. (0.84 mm) to 0.112 in. (2.84 mm) in Thickness	9.24.1.4.(1)
ASTM	C 991-08e1	Flexible Fibrous Glass Insulation for Metal Buildings	Table 5.10.1.1.
ASTM	C 1002-07	Steel Self-Piercing Tapping Screws for the Application of Gypsum Panel Products or Metal Plaster Bases to Wood Studs or Steel Studs	Table 5.10.1.1. 9.24.1.4.(1) 9.29.5.7.(1)
ASTM	C 1177/C 1177M-08	Glass Mat Gypsum Substrate for Use as Sheathing	Table 5.10.1.1. Table 9.23.17.2.A.
ASTM	C 1178/C 1178M-11	Coated Glass Mat Water-Resistant Gypsum Backing Panel	Table 5.10.1.1. 9.29.5.2.(1)
ASTM	C 1184-05	Structural Silicone Sealants	Table 5.10.1.1. 9.27.4.2.(2)
ASTM	C 1311-10	Solvent Release Sealants	Table 5.10.1.1. 9.27.4.2.(2)
ASTM	C 1330-02	Cylindrical Sealant Backing for Use with Cold Liquid-Applied Sealants	Table 5.10.1.1. 9.27.4.2.(3)
ASTM	C 1363-05	Thermal Performance of Building Materials and Envelope Assemblies by Means of a Hot Box Apparatus	9.36.2.2.(4)
ASTM	C 1396/C 1396M-11	Gypsum Board	3.1.5.12.(4) Table 5.10.1.1. Table 9.23.17.2.A. 9.29.5.2.(1) Table 9.29.5.3.
ASTM	D 323-08	Vapor Pressure of Petroleum Products (Reid Method)	1.4.1.2.(1) <sup>(4)</sup>
ASTM	D 2178-04	Asphalt Glass Felt Used in Roofing and Waterproofing	Table 5.10.1.1.
ASTM	D 2898-10	Accelerated Weathering of Fire-Retardant-Treated Wood for Fire Testing	3.1.5.5.(5) 3.1.5.21.(1) 3.2.3.7.(4) 9.10.14.5.(3) 9.10.15.5.(3)
ASTM	E 90-04	Laboratory Measurement of Airborne Sound Transmission Loss of Building Partitions and Elements	5.9.1.1.(1) 9.11.1.1.(1)
ASTM	E 96/E 96M-10	Water Vapor Transmission of Materials	5.5.1.2.(3) 9.25.4.2.(1) 9.25.5.1.(1) 9.30.1.2.(1)
ASTM	E 336-05	Measurement of Airborne Sound Attenuation between Rooms in Buildings	5.9.1.1.(1) 9.11.1.1.(1)
ASTM	E 413-04	Classification for Rating Sound Insulation	5.9.1.1.(1) 9.11.1.1.(1)

**Table 1.3.1.2. (Continued)**

Issuing Agency	Document Number <sup>(1)(2)</sup>	Title of Document <sup>(3)</sup>	Code Reference
ASTM	E 2190-10	Insulating Glass Unit Performance and Evaluation	Table 5.10.1.1. 9.6.1.2.(1)
ASTM	E 2357-11	Determining Air Leakage of Air Barrier Assemblies	9.36.2.9.(1)
ASTM	F 476-84	Security of Swinging Door Assemblies	9.7.5.2.(2)
ASTM	F 1667-05	Driven Fasteners: Nails, Spikes, and Staples	9.23.3.1.(1) 9.26.2.2.(1) 9.29.5.6.(1)
AWPA	M4-11	Care of Preservative-Treated Wood Products	4.2.3.2.(2) Table 5.10.1.1.
BNQ	BNQ 3624-115/2007	Polyethylene (PE) Pipe and Fittings – Flexible Pipes for Drainage – Characteristics and Test Methods	Table 5.10.1.1. 9.14.3.1.(1)
CCBFC	NRCC 38732	National Farm Building Code of Canada 1995	1.1.1.1.(3) <sup>(4)</sup>
CCBFC	NRCC 53302	National Plumbing Code of Canada 2010	2.1.1.2.(4) <sup>(4)</sup> 5.6.2.2.(2) 7.1.2.1.(1) 9.31.6.2.(1)
CCBFC	NRCC 53303	National Fire Code of Canada 2010	1.1.4.1.(1) 1.4.1.2.(1) <sup>(4)</sup> 2.1.1.2.(4) <sup>(4)</sup> 3.1.13.1.(1) 3.2.3.21.(1) 3.2.4.6.(1) 3.2.5.16.(1) 3.3.1.2.(1) 3.3.1.10.(1) 3.3.2.3.(1) 3.3.2.15.(1) 3.3.4.3.(4) 3.3.5.2.(1) 3.3.6.1.(1) 3.3.6.3.(1) 3.3.6.3.(2) 3.3.6.4.(1) 3.3.6.4.(2) 3.3.6.6.(1) 6.2.2.6.(1) 6.2.12.2.(3) 6.2.12.3.(1) 6.2.12.4.(1) 8.1.1.1.(3) 8.1.1.3.(1) 9.10.1.2.(1) 9.10.20.4.(1) 9.10.21.8.(1)
CCBFC	NRCC 54435	National Energy Code of Canada for Buildings 2011	9.36.1.3.(1) 9.36.1.3.(4) 9.36.3.1.(2) 9.36.4.1.(2)
CGSB	CAN/CGSB-1.501-M89	Method for Permeance of Coated Wallboard	5.5.1.2.(2) 9.25.4.2.(5)
CGSB	CAN/CGSB-7.2-94	Adjustable Steel Columns	9.17.3.4.(1)
CGSB	CAN/CGSB-10.3-92	Air Setting Refractory Mortar	9.21.3.4.(2) 9.21.3.9.(1) 9.22.2.2.(2)

Table 1.3.1.2. (Continued)

Issuing Agency	Document Number <sup>(1)(2)</sup>	Title of Document <sup>(3)</sup>	Code Reference
CGSB	CAN/CGSB-11.3-M87	Hardboard	Table 5.10.1.1. 9.27.9.1.(2) 9.29.7.1.(1) 9.30.2.2.(1)
CGSB	CAN/CGSB-11.5-M87	Hardboard, Precoated, Factory Finished, for Exterior Cladding	Table 5.10.1.1. 9.27.9.1.(1)
CGSB	CAN/CGSB-12.1-M90	Tempered or Laminated Safety Glass	3.3.1.19.(2) 3.4.6.15.(1) 3.4.6.15.(3) Table 5.10.1.1. 9.6.1.2.(1) 9.6.1.4.(1) 9.8.8.7.(1)
CGSB	CAN/CGSB-12.2-M91	Flat, Clear Sheet Glass	Table 5.10.1.1. 9.6.1.2.(1)
CGSB	CAN/CGSB-12.3-M91	Flat, Clear Float Glass	Table 5.10.1.1. 9.6.1.2.(1)
CGSB	CAN/CGSB-12.4-M91	Heat Absorbing Glass	Table 5.10.1.1. 9.6.1.2.(1)
CGSB	CAN/CGSB-12.8-97	Insulating Glass Units	Table 5.10.1.1. 9.6.1.2.(1)
CGSB	CAN/CGSB-12.10-M76	Glass, Light and Heat Reflecting	Table 5.10.1.1. 9.6.1.2.(1)
CGSB	CAN/CGSB-12.11-M90	Wired Safety Glass	3.3.1.19.(2) 3.4.6.15.(1) 3.4.6.15.(3) Table 5.10.1.1. 9.6.1.2.(1) 9.6.1.4.(1) 9.8.8.7.(1)
CGSB	CAN/CGSB-12.20-M89	Structural Design of Glass for Buildings	4.3.6.1.(1) 9.6.1.3.(1)
CGSB	CAN/CGSB-19.22-M89	Mildew-Resistant Sealing Compound for Tubs and Tiles	9.29.10.5.(1)
CGSB	CAN/CGSB-34.22-94	Asbestos-Cement Drain Pipe	Table 5.10.1.1. 9.14.3.1.(1)
CGSB	CAN/CGSB-37.1-M89	Chemical Emulsifier Type, Emulsified Asphalt for Dampproofing	Table 5.10.1.1. 9.13.2.2.(1)
CGSB	CAN/CGSB-37.2-M88	Emulsified Asphalt, Mineral-Colloid Type, Unfilled, for Dampproofing and Waterproofing and for Roof Coatings	Table 5.10.1.1. 9.13.2.2.(1) 9.13.3.2.(1)
CGSB	CAN/CGSB-37.3-M89	Application of Emulsified Asphalts for Dampproofing or Waterproofing	5.8.2.3.(1) Table 5.10.1.1. 9.13.2.3.(1) 9.13.3.3.(1)
CGSB	CAN/CGSB-37.4-M89	Fibrated, Cutback Asphalt, Lap Cement for Asphalt Roofing	Table 5.10.1.1. 9.26.2.1.(1)
CGSB	CAN/CGSB-37.5-M89	Cutback Asphalt Plastic, Cement	Table 5.10.1.1. 9.26.2.1.(1)
CGSB	37-GP-6Ma-1983	Asphalt, Cutback, Unfilled, for Dampproofing	5.8.2.2.(6) 5.8.2.2.(7) Table 5.10.1.1. 9.13.2.2.(1)
CGSB	CAN/CGSB-37.8-M88	Asphalt, Cutback, Filled, for Roof Coating	Table 5.10.1.1. 9.26.2.1.(1)

**Table 1.3.1.2. (Continued)**

Issuing Agency	Document Number <sup>(1)(2)</sup>	Title of Document <sup>(3)</sup>	Code Reference
CGSB	37-GP-9Ma-1983	Primer, Asphalt, Unfilled, for Asphalt Roofing, Dampproofing and Waterproofing	Table 5.10.1.1. 9.26.2.1.(1)
CGSB	37-GP-12Ma-1984	Application of Unfilled Cutback Asphalt for Dampproofing	5.8.2.3.(2) Table 5.10.1.1. 9.13.2.3.(1)
CGSB	CAN/CGSB-37.16-M89	Filled, Cutback Asphalt for Dampproofing and Waterproofing	Table 5.10.1.1. 9.13.2.2.(1) 9.13.3.2.(1)
CGSB	37-GP-18Ma-1985	Tar, Cutback, Unfilled, for Dampproofing	5.8.2.2.(6) 5.8.2.2.(7) Table 5.10.1.1. 9.13.2.2.(1)
CGSB	37-GP-21M-1985	Tar, Cutback, Fibrated, for Roof Coating	Table 5.10.1.1. 9.26.2.1.(1)
CGSB	CAN/CGSB-37.22-M89	Application of Unfilled, Cutback Tar Foundation Coating for Dampproofing	5.8.2.3.(2) Table 5.10.1.1. 9.13.2.3.(1)
CGSB	37-GP-36M-1976	Application of Filled Cutback Asphalts for Dampproofing and Waterproofing	5.8.2.3.(1) Table 5.10.1.1.
CGSB	37-GP-37M-1977	Application of Hot Asphalt for Dampproofing or Waterproofing	5.8.2.3.(1) Table 5.10.1.1.
CGSB	CAN/CGSB-37.50-M89	Hot-Applied, Rubberized Asphalt for Roofing and Waterproofing	Table 5.10.1.1. 9.26.2.1.(1)
CGSB	CAN/CGSB-37.51-M90	Application for Hot-Applied Rubberized Asphalt for Roofing and Waterproofing	5.6.1.2.(1) 5.8.2.3.(1) Table 5.10.1.1. 9.26.15.1.(1)
CGSB	37-GP-52M-1984	Roofing and Waterproofing Membrane, Sheet Applied, Elastomeric	Table 5.10.1.1. 9.26.2.1.(1)
CGSB	CAN/CGSB-37.54-95	Polyvinyl Chloride Roofing and Waterproofing Membrane	Table 5.10.1.1. 9.26.2.1.(1)
CGSB	37-GP-55M-1979	Application of Sheet Applied Flexible Polyvinyl Chloride Roofing Membrane	5.6.1.2.(1) Table 5.10.1.1. 9.26.16.1.(1)
CGSB	37-GP-56M-1985	Membrane, Modified, Bituminous, Prefabricated, and Reinforced for Roofing	Table 5.10.1.1. 9.26.2.1.(1)
CGSB	37-GP-64M-1977	Mat Reinforcing, Fibrous Glass, for Membrane Waterproofing Systems and Built-Up Roofing	Table 5.10.1.1.
CGSB	41-GP-6M-1983	Sheets, Thermosetting Polyester Plastics, Glass Fiber Reinforced	Table 5.10.1.1. 9.26.2.1.(1)
CGSB	CAN/CGSB-41.24-95	Rigid Vinyl Siding, Soffits and Fascia	Table 5.10.1.1. 9.27.12.1.(1)
CGSB	CAN/CGSB-51.25-M87	Thermal Insulation, Phenolic, Faced	Table 9.23.17.2.A. 9.25.2.2.(1)
CGSB	51-GP-27M-1979	Thermal Insulation, Polystyrene, Loose Fill	9.25.2.2.(1)
CGSB	CAN/CGSB-51.32-M77	Sheathing, Membrane, Breather Type	Table 5.10.1.1. 9.20.13.9.(1) 9.26.2.1.(1) 9.27.3.2.(1)
CGSB	CAN/CGSB-51.33-M89	Vapour Barrier Sheet, Excluding Polyethylene, for Use in Building Construction	Table 5.10.1.1. 9.25.4.2.(4)

Table 1.3.1.2. (Continued)

Issuing Agency	Document Number <sup>(1)(2)</sup>	Title of Document <sup>(3)</sup>	Code Reference
CGSB	CAN/CGSB-51.34-M86	Vapour Barrier, Polyethylene Sheet for Use in Building Construction	Table 5.10.1.1. 9.13.2.2.(1) 9.18.6.2.(1) 9.25.3.2.(2) 9.25.3.6.(1) 9.25.4.2.(3)
CGSB	CAN/CGSB-51.71-95	The Spillage Test: Method to Determine the Potential for Pressure-Induced Spillage from Vented, Fuel-Fired, Space Heating Appliances, Water Heaters and Fireplaces	9.32.3.8.(7)
CGSB	CAN/CGSB-82.6-M86	Doors, Mirrored Glass, Sliding or Folding, Wardrobe	9.6.1.2.(2)
CGSB	CAN/CGSB-93.1-M85	Sheet, Aluminum Alloy, Prefinished, Residential	Table 5.10.1.1. 9.27.11.1.(4)
CGSB	CAN/CGSB-93.2-M91	Prefinished Aluminum Siding, Soffits, and Fascia, for Residential Use	3.2.3.6.(4) Table 5.10.1.1. 9.10.14.5.(8) 9.10.14.5.(11) 9.10.15.5.(7) 9.10.15.5.(10) 9.27.11.1.(3)
CGSB	CAN/CGSB-93.3-M91	Prefinished Galvanized and Aluminum-Zinc Alloy Steel Sheet for Residential Use	Table 5.10.1.1. 9.27.11.1.(2)
CGSB	CAN/CGSB-93.4-92	Galvanized Steel and Aluminum-Zinc Alloy Coated Steel Siding, Soffits and Fascia, Prefinished, Residential	Table 5.10.1.1. 9.27.11.1.(1)
CGSB	CAN/CGSB-149.10-M86	Determination of the Airtightness of Building Envelopes by the Fan Depressurization Method	9.36.5.10.(11)
CSA	CAN/CSA-6.19-01	Residential Carbon Monoxide Alarming Devices	6.2.4.1.(2) 9.32.3.9.(2) 9.32.3.9.(3)
CSA	A23.1-09	Concrete Materials and Methods of Concrete Construction	4.2.3.6.(1) 4.2.3.9.(1) Table 5.10.1.1. 9.3.1.1.(1) 9.3.1.1.(4) 9.3.1.3.(1) 9.3.1.4.(1)
CSA	CAN/CSA-A23.3-04	Design of Concrete Structures	Table 4.1.8.9. 4.3.3.1.(1)
CSA	CAN/CSA-A82.1-M87	Burned Clay Brick (Solid Masonry Units Made from Clay or Shale)	Table 5.10.1.1. 9.20.2.1.(1)
CSA	A82.4-M1978	Structural Clay Load-Bearing Wall Tile	Table 5.10.1.1. 9.20.2.1.(1)
CSA	A82.5-M1978	Structural Clay Non-Load-Bearing Tile	Table 5.10.1.1. 9.20.2.1.(1)
CSA	CAN3-A82.8-M78	Hollow Clay Brick	Table 5.10.1.1. 9.20.2.1.(1)
CSA	CAN/CSA-A82.27-M91	Gypsum Board	3.1.5.12.(4) Table 5.10.1.1. Table 9.23.17.2.A. 9.29.5.2.(1)
CSA	A82.30-M1980	Interior Furring, Lathing and Gypsum Plastering	Table 5.10.1.1. 9.29.4.1.(1)

**Table 1.3.1.2. (Continued)**

Issuing Agency	Document Number <sup>(1)(2)</sup>	Title of Document <sup>(3)</sup>	Code Reference
CSA	A82.31-M1980	Gypsum Board Application	3.2.3.6.(4) Table 5.10.1.1. 9.10.9.2.(4) 9.10.12.4.(3) 9.10.14.5.(8) 9.10.14.5.(11) 9.10.15.5.(7) 9.10.15.5.(10) 9.29.5.1.(2)
CSA	CAN3-A93-M82	Natural Airflow Ventilators for Buildings	Table 5.10.1.1. 9.19.1.2.(5)
CSA	A123.1-05/A123.5-05	Asphalt Shingles Made From Organic Felt and Surfaced with Mineral Granules/Asphalt Shingles Made From Glass Felt and Surfaced with Mineral Granules	Table 5.10.1.1. 9.26.2.1.(1)
CSA	CAN/CSA-A123.2-03	Asphalt-Coated Roofing Sheets	Table 5.10.1.1. 9.26.2.1.(1)
CSA	A123.3-05	Asphalt Saturated Organic Roofing Felt	Table 5.10.1.1. 9.26.2.1.(1)
CSA	CAN/CSA-A123.4-04	Asphalt for Constructing Built-Up Roof Coverings and Waterproofing Systems	Table 5.10.1.1. 9.13.2.2.(1) 9.13.3.2.(1) 9.26.2.1.(1)
CSA	A123.17-05	Asphalt Glass Felt Used in Roofing and Waterproofing	Table 5.10.1.1. 9.26.2.1.(1)
CSA	CAN3-A123.51-M85	Asphalt Shingle Application on Roof Slopes 1:3 and Steeper	5.6.1.2.(1) Table 5.10.1.1. 9.26.1.2.(1)
CSA	CAN3-A123.52-M85	Asphalt Shingle Application on Roof Slopes 1:6 to Less Than 1:3	5.6.1.2.(1) Table 5.10.1.1. 9.26.1.2.(1)
CSA	CAN/CSA-A165.1-04	Concrete Block Masonry Units	Table 5.10.1.1. 9.15.2.2.(1) 9.17.5.1.(1) 9.20.2.1.(1) 9.20.2.6.(1)
CSA	CAN/CSA-A165.2-04	Concrete Brick Masonry Units	Table 5.10.1.1. 9.20.2.1.(1)
CSA	CAN/CSA-A165.3-04	Prefaced Concrete Masonry Units	Table 5.10.1.1. 9.20.2.1.(1)
CSA	CAN3-A165.4-M85	Autoclaved Cellular Units	Table 5.10.1.1. 9.20.2.1.(1)
CSA	CAN/CSA-A179-04	Mortar and Grout for Unit Masonry	Table 5.10.1.1. 9.15.2.2.(3) 9.20.3.1.(1)
CSA	CAN/CSA-A220 Series-06	Concrete Roof Tiles	Table 5.10.1.1. 9.26.2.1.(1) 9.26.17.1.(1)
CSA	CAN/CSA-A324-M88	Clay Flue Liners	9.21.3.3.(1)
CSA	CAN/CSA-A371-04	Masonry Construction for Buildings	5.6.1.2.(2) Table 5.10.1.1. 9.15.2.2.(3) 9.20.3.2.(7) 9.20.15.2.(1)

Table 1.3.1.2. (Continued)

Issuing Agency	Document Number <sup>(1)(2)</sup>	Title of Document <sup>(3)</sup>	Code Reference
CSA	CAN/CSA-A405-M87	Design and Construction of Masonry Chimneys and Fireplaces	9.21.3.5.(1) 9.22.1.4.(1) 9.22.5.2.(2)
CSA	AAMA/WDMA/CSA 101/I.S.2/A440-11	NAFS – North American Fenestration Standard/Specification for Windows, Doors, and Skylights	5.10.2.2.(1) 5.10.2.2.(3) Table 9.7.3.3. 9.7.4.1.(1) 9.7.4.2.(1) 9.7.4.3.(2) 9.7.5.1.(1) 9.7.5.3.(1) 9.36.2.9.(3)
CSA	A440S1-09	Canadian Supplement to AAMA/WDMA/CSA 101/I.S.2/A440, NAFS – North American Fenestration Standard/Specification for Windows, Doors, and Skylights	5.10.2.2.(1) 9.7.4.2.(1) 9.36.2.9.(3)
CSA	CAN/CSA-A440.2-09/A440.3-09	Fenestration Energy Performance/User Guide to CSA A440.2-09, Fenestration Energy Performance	Table 9.7.3.3. 9.36.2.2.(3)
CSA	CAN/CSA-A440.4-07	Window, Door, and Skylight Installation	9.7.6.1.(1)
CSA	A660-10	Certification of Manufacturers of Steel Building Systems	4.3.4.3.(1)
CSA	CAN/CSA-A3001-08	Cementitious Materials for Use in Concrete	Table 5.10.1.1. 9.3.1.2.(1) 9.28.2.1.(1)
CSA	B51-09	Boiler, Pressure Vessel, and Pressure Piping Code	6.2.1.4.(1) 9.31.6.2.(2) 9.33.5.2.(1)
CSA	B52-05	Mechanical Refrigeration Code	6.2.1.4.(1) 9.33.5.2.(1)
CSA	CAN/CSA-B72-M87	Installation Code for Lightning Protection Systems	6.3.1.4.(1)
CSA	B111-1974	Wire Nails, Spikes and Staples	9.23.3.1.(1) 9.26.2.2.(1) 9.29.5.6.(1)
CSA	B139-09	Installation Code for Oil-Burning Equipment	6.2.1.4.(1) 9.31.6.2.(2) 9.33.5.2.(1)
CSA	B140.12-03	Oil-Burning Equipment: Service Water Heaters for Domestic Hot Water, Space Heating, and Swimming Pools	Table 9.36.4.2.
CSA	B149.1-10	Natural Gas and Propane Installation Code	6.2.1.4.(1) 9.10.22.1.(1) 9.31.6.2.(2) 9.33.5.2.(1)
CSA	CAN/CSA-B182.1-11	Plastic Drain and Sewer Pipe and Pipe Fittings	Table 5.10.1.1. 9.14.3.1.(1)
CSA	CAN/CSA-B211-00	Energy Efficiency of Oil-Fired Storage Tank Water Heaters	Table 9.36.4.2.
CSA	B212-00	Energy Utilization Efficiencies of Oil-Fired Furnaces and Boilers	9.36.3.10.
CSA	B214-12	Installation Code for Hydronic Heating Systems	6.2.1.1.(1) 9.33.4.2.(1)
CSA	B355-09	Lifts for Persons with Physical Disabilities	3.8.3.5.(1)
CSA	B365-10	Installation Code for Solid-Fuel-Burning Appliances and Equipment	6.2.1.4.(1) 9.22.10.2.(1) 9.31.6.2.(2) 9.33.5.3.(1)
CSA	B415.1-10	Solid-Fuel-Burning Heating Appliances	Table 9.36.3.10.



**Table 1.3.1.2. (Continued)**

Issuing Agency	Document Number <sup>(1)(2)</sup>	Title of Document <sup>(3)</sup>	Code Reference
CSA	C22.1-12	Canadian Electrical Code, Part I	3.3.6.2.(4) 3.6.1.2.(1) 3.6.2.1.(6) 3.6.2.7.(1) 6.2.1.4.(1) 9.31.6.2.(2) 9.33.5.2.(1) 9.34.1.1.(1)
CSA	C22.2 No. 0.3-09	Test Methods for Electrical Wires and Cables	3.1.4.3.(1) 3.1.4.3.(2) 3.1.5.18.(1) 3.1.5.18.(3) 9.34.1.5.(1)
CSA	C22.2 No. 113-10	Fans and Ventilators	9.32.3.10.(7)
CSA	C22.2 No. 141-10	Emergency Lighting Equipment	3.2.7.4.(2) 3.4.5.1.(3) 9.9.11.3.(3) 9.9.12.3.(7)
CSA	C22.2 No. 211.0-03	General Requirements and Methods of Testing for Nonmetallic Conduit	3.1.5.20.(1)
CSA	CAN/CSA-C22.2 No. 262-04	Optical Fiber Cable and Communication Cable Raceway Systems	3.1.5.20.(1)
CSA	CAN/CSA-C191-04	Electric Storage Tank Water Heaters for Domestic Hot Water Service	Table 9.36.4.2.
CSA	CAN/CSA-C260-M90	Rating the Performance of Residential Mechanical Ventilating Equipment	9.32.3.10.(1) 9.32.3.10.(2) Table 9.32.3.10.B.
CSA	C282-09	Emergency Electrical Power Supply for Buildings	3.2.7.5.(1)
CSA	CAN/CSA-C368.1-M90	Room Air Conditioners	Table 9.36.3.10.
CSA	CAN/CSA-C439-09	Rating the Performance of Heat/Energy-Recovery Ventilators	9.32.3.10.(4) 9.32.3.10.(5) 9.36.3.8.(4) 9.36.3.9.(3)
CSA	CAN/CSA-C448 Series-02	Design and Installation of Earth Energy Systems	9.33.5.2.(1)
CSA	CAN/CSA-C656-05	Split-System and Single-Package Central Air Conditioners and Heat Pumps	Table 9.36.3.10.
CSA	CAN/CSA-C745-03	Energy Efficiency of Electric Storage Tank Water Heaters and Heat Pump Water Heaters	Table 9.36.4.2.
CSA	CAN/CSA-C746-06	Rating Large and Single Packaged Vertical Air Conditioners and Heat Pumps	Table 9.36.3.10.
CSA	C748-94	Direct-Expansion (DX) Ground-Source Heat Pumps	Table 9.36.3.10.
CSA	CAN/CSA-C749-07	Performance of Dehumidifiers	Table 9.36.3.10.
CSA	CAN/CSA-C828-06	Thermostats Used with Individual Room Electric Space Heating Devices	9.36.3.6.(3)
CSA	CAN/CSA-C13256-1-01	Water-Source Heat Pumps - Testing and Rating for Performance - Part 1: Water-to-Air and Brine-to-Air Heat Pumps (Adopted ISO 13256-1:1998, with Canadian Deviations)	Table 9.36.3.10.
CSA	CAN/CSA-C13256-2-01	Water-Source Heat Pumps - Testing and Rating for Performance - Part 2: Water-to-Water and Brine-to-Water Heat Pumps (Adopted ISO 13256-2:1998, with Canadian Deviations)	Table 9.36.3.10.
CSA	F280-12	Determining the Required Capacity of Residential Space Heating and Cooling Appliances	9.33.5.1.(1)
CSA	CAN/CSA-F326-M91	Residential Mechanical Ventilation Systems	9.32.3.1.(1)
CSA	G30.18-09	Carbon Steel Bars for Concrete Reinforcement	9.3.1.1.(4)

Table 1.3.1.2. (Continued)

Issuing Agency	Document Number <sup>(1)(2)</sup>	Title of Document <sup>(3)</sup>	Code Reference
CSA	G40.21-04	Structural Quality Steel	4.2.3.8.(1) Table 5.10.1.1. 9.23.4.3.(2)
CSA	CAN/CSA-G401-07	Corrugated Steel Pipe Products	Table 5.10.1.1. 9.14.3.1.(1)
CSA	CAN/CSA-O80 Series-08	Wood Preservation	3.1.4.5.(1) 4.2.3.2.(1) 4.2.3.2.(2) Table 5.10.1.1.
CSA	CAN/CSA-O80.1-08	Specification of Treated Wood	9.3.2.9.(5)
CSA	CAN/CSA-O80.2-08	Processing and Treatment	4.2.3.2.(1)
CSA	CAN/CSA-O80.3-08	Preservative Formulations	4.2.3.2.(1)
CSA	O80.15-97	Preservative Treatment of Wood for Building Foundation Systems, Basements, and Crawl Spaces by Pressure Processes	4.2.3.2.(1)
CSA	O86-09	Engineering Design in Wood	Table 4.1.8.9. 4.3.1.1.(1)
CSA	O115-M1982	Hardwood and Decorative Plywood	Table 5.10.1.1. 9.27.8.1.(1) 9.30.2.2.(1)
CSA	O118.1-08	Western Red Cedar Shakes and Shingles	Table 5.10.1.1. 9.26.2.1.(1) 9.27.7.1.(1)
CSA	O118.2-08	Eastern White Cedar Shingles	Table 5.10.1.1. 9.26.2.1.(1) 9.27.7.1.(1)
CSA	O121-08	Douglas Fir Plywood	Table 5.10.1.1. 9.23.15.2.(1) 9.23.16.2.(1) Table 9.23.17.2.A. 9.27.8.1.(1) 9.30.2.2.(1) Table A-13 Table A-14 Table A-15
CSA	CAN/CSA-O122-06	Structural Glued-Laminated Timber	Table A-11 Table A-16
CSA	CAN/CSA-O132.2 Series-90	Wood Flush Doors	9.7.4.3.(4)
CSA	O141-05	Softwood Lumber	Table 5.10.1.1. 9.3.2.6.(1)
CSA	O151-09	Canadian Softwood Plywood	Table 5.10.1.1. 9.23.15.2.(1) 9.23.16.2.(1) Table 9.23.17.2.A. 9.27.8.1.(1) 9.30.2.2.(1) Table A-13 Table A-14 Table A-15
CSA	O153-M1980	Poplar Plywood	Table 5.10.1.1. 9.23.15.2.(1) 9.23.16.2.(1) Table 9.23.17.2.A. 9.27.8.1.(1) 9.30.2.2.(1)

**Table 1.3.1.2. (Continued)**

Issuing Agency	Document Number <sup>(1)(2)</sup>	Title of Document <sup>(3)</sup>	Code Reference
CSA	O177-06	Qualification Code for Manufacturers of Structural Glued-Laminated Timber	4.3.1.2.(1) Table A-11 Table A-16
CSA	O325-07	Construction Sheathing	Table 5.10.1.1. Table 9.23.13.6. 9.23.15.2.(1) 9.23.15.4.(2) Table 9.23.15.5.B. 9.23.16.2.(1) 9.23.16.3.(2) Table 9.23.16.7.B. Table 9.23.17.2.B. 9.29.9.1.(2) 9.29.9.2.(5) Table A-13 Table A-14 Table A-15
CSA	O437.0-93	OSB and Waferboard	Table 5.10.1.1. 9.23.15.2.(1) 9.23.15.4.(2) 9.23.16.2.(1) 9.23.16.3.(2) Table 9.23.17.2.A. 9.27.10.1.(1) 9.29.9.1.(2) 9.30.2.2.(1) Table A-13 Table A-14 Table A-15
CSA	CAN/CSA-P.2-07	Measuring the Annual Fuel Utilization Efficiency of Residential Gas-Fired Furnaces and Boilers	Table 9.36.3.10.
CSA	CAN/CSA-P.3-04	Measuring Energy Consumption and Determining Efficiencies of Gas-Fired Storage Water Heaters	Table 9.36.4.2.
CSA	P.6-09	Measuring Thermal Efficiency of Gas-Fired Pool Heaters	Table 9.36.4.2.
CSA	CAN/CSA-P.7-10	Measuring Energy Loss of Gas-Fired Instantaneous Water Heaters	Table 9.36.4.2.
CSA	CAN/CSA-P.8-09	Thermal Efficiencies of Industrial and Commercial Gas-Fired Package Furnaces	Table 9.36.3.10.
CSA	CAN/CSA-P.9-11	Performance of Combined Space and Water Heating Systems (Combos)	Table 9.36.3.10. 9.36.3.10.(3) Table 9.36.4.2. Table 9.36.5.15.C.
CSA	P.10-07	Performance of Integrated Mechanical Systems for Residential Heating and Ventilation	9.36.3.9.(2) Table 9.36.3.10. Table 9.36.4.2. Table 9.36.5.15.C.
CSA	CAN/CSA-P.11-07	Measuring Efficiency and Energy Consumption of Gas-Fired Unit Heaters	Table 9.36.3.10.
CSA	S16-09	Design of Steel Structures	Table 4.1.8.9. 4.3.4.1.(1)
CSA	CAN/CSA-S136-07	North American Specification for the Design of Cold-Formed Steel Structural Members (using the Appendix B provisions applicable to Canada)	Table 4.1.8.9. 4.3.4.2.(1)
CSA	CAN/CSA-S157-05/S157.1-05	Strength Design in Aluminum/Commentary on CSA S157-05, Strength Design in Aluminum	4.3.5.1.(1)
CSA	S269.1-1975	Falsework for Construction Purposes	4.1.1.3.(4)

Table 1.3.1.2. (Continued)

Issuing Agency	Document Number <sup>(1)(2)</sup>	Title of Document <sup>(3)</sup>	Code Reference
CSA	CAN/CSA-S269.2-M87	Access Scaffolding for Construction Purposes	4.1.1.3.(4)
CSA	CAN/CSA-S269.3-M92	Concrete Formwork	4.1.1.3.(4)
CSA	S304.1-04	Design of Masonry Structures	Table 4.1.8.9. 4.3.2.1.(1)
CSA	S307-M1980	Load Test Procedure for Wood Roof Trusses for Houses and Small Buildings	9.23.14.11.(5)
CSA	S367-09	Air-, Cable-, and Frame-Supported Membrane Structures	4.4.1.1.(1)
CSA	CAN/CSA-S406-92	Construction of Preserved Wood Foundations	9.15.2.4.(1) 9.16.5.1.(1)
CSA	S413-07	Parking Structures	4.4.2.1.(1)
CSA	Z32-09	Electrical Safety and Essential Electrical Systems in Health Care Facilities	3.2.7.3.(4) 3.2.7.6.(1)
CSA	Z240.2.1-09	Structural Requirements for Manufactured Homes	9.12.2.2.(6) 9.15.1.3.(1)
CSA	Z240.10.1-08	Site Preparation, Foundation, and Anchorage of Manufactured Homes	9.15.1.3.(1) 9.23.6.3.(1)
CSA	CAN/CSA-Z317.2-10	Special Requirements for Heating, Ventilation, and Air-Conditioning (HVAC) Systems in Health Care Facilities	6.2.1.1.(1)
CSA	Z662-11/Z662.1-11	Oil and Gas Pipeline Systems/Commentary on CSA Z662-11	3.2.3.22.(1)
CSA	Z7396.1-09	Medical Gas Pipeline Systems – Part 1: Pipelines for Medical Gases and Vacuum	3.7.3.1.(1)
CTI	201(04)	Certification of Water-Cooling Tower Thermal Performance	Table 9.36.3.10.
CWC	2009	Engineering Guide for Wood Frame Construction	9.4.1.1.(1) 9.23.13.1.(2) 9.23.13.2.(2) 9.23.13.3.(2)
DOE	10 CFR, Part 430-2011	Energy, Energy Conservation Program for Consumer Products	Table 9.36.4.2.
DOE	10 CFR, Part 431-2011	Energy, Energy Efficiency Program for Certain Commercial and Industrial Equipment	Table 9.36.4.2.
EC	CEPA 1988	Canadian Environmental Protection Act, Section 8, Part 1	6.2.1.7.(2)
EPA	40 CFR, Part 60-2008	Protection of Environment, Standards of Performance for New Stationary Sources	Table 9.36.3.10.
EPA	625/R-92/016 (1994)	Radon Prevention in the Design and Construction of Schools and Other Large Buildings	6.2.1.1.(1)
HVI	HVI Publication 915-2009	Loudness Testing and Rating Procedure	9.32.3.10.(2) Table 9.32.3.10.B.
HVI	HVI Publication 916-2009	Airflow Test Procedure	9.32.3.10.(1)
ICC	400-2007	Design and Construction of Log Structures	9.36.2.2.(5)
ISO	3864-1:2011	Graphical symbols – Safety colours and safety signs – Part 1: Design principles for safety signs and safety markings	3.4.5.1.(2) 9.9.11.3.(2)
ISO	7010:2003	Graphical symbols – Safety colours and safety signs – Safety signs used in workplaces and public areas	3.4.5.1.(2) 9.9.11.3.(2)
ISO	8201:1987(E)	Acoustics – Audible emergency evacuation signal	3.2.4.19.(2)
NFPA	13-2013 <sup>(5)</sup>	Installation of Sprinkler Systems	3.1.9.1.(4) 3.2.4.9.(2) 3.2.4.16.(1) 3.2.5.12.(1) 3.3.2.13.(3) 9.10.9.6.(11)

**Table 1.3.1.2. (Continued)**

Issuing Agency	Document Number <sup>(1)(2)</sup>	Title of Document <sup>(3)</sup>	Code Reference
NFPA	13D-2010	Installation of Sprinkler Systems in One- and Two-Family Dwellings and Manufactured Homes	3.2.4.1.(2) 3.2.5.12.(3) 9.10.18.2.(3)
NFPA	13R-2010	Installation of Sprinkler Systems in Residential Occupancies up to and Including Four Stories in Height	3.2.5.12.(2)
NFPA	14-2010	Installation of Standpipe and Hose Systems	3.2.5.9.(1) 3.2.5.10.(1)
NFPA	20-2010	Installation of Stationary Pumps for Fire Protection	3.2.4.10.(4) 3.2.5.18.(1)
NFPA	68-2007	Explosion Protection by Deflagration Venting	3.3.6.4.(2)
NFPA	80-2010	Fire Doors and Other Opening Protectives	3.1.8.5.(2) 3.1.8.10.(2) 3.1.8.14.(1) 3.1.9.1.(5) 9.10.9.6.(13) 9.10.13.1.(1)
NFPA	82-2009	Incinerators and Waste and Linen Handling Systems and Equipment	6.2.6.1.(1) 9.10.10.5.(2)
NFPA	91-2010	Exhaust Systems for Air Conveying of Vapors, Gases, Mists, and Noncombustible Particulate Solids	6.2.12.3.(1)
NFPA	96-2011	Ventilation Control and Fire Protection of Commercial Cooking Operations	3.2.4.9.(2) 6.2.2.7.(1)
NFPA	101-2012	Life Safety Code	3.3.2.1.(2) 3.3.2.1.(3)
NFPA	211-2010	Chimneys, Fireplaces, Vents, and Solid Fuel-Burning Appliances	6.3.1.2.(2) 6.3.1.3.(1)
NFPA	214-2011	Water-Cooling Towers	6.2.3.14.(3)
NFRC	100-2010	Determining Fenestration Product U-factors	9.36.2.2.(3)
NFRC	200-2010	Determining Fenestration Product Solar Heat Gain Coefficient and Visible Transmittance at Normal Incidence	9.36.2.2.(3)
NLGA	2010	Standard Grading Rules for Canadian Lumber	9.3.2.1.(1) Table A-1 Table A-2 Table A-3 Table A-4 Table A-5 Table A-6 Table A-7 Table A-8 Table A-9 Table A-10
SMACNA	ANSI/SMACNA 006-2006	HVAC Duct Construction Standards – Metal and Flexible	9.33.6.5.(2)
TC	SOR/96-433	Canadian Aviation Regulations – Part III	4.1.5.13.(1)
TPIC	2011	Truss Design Procedures and Specifications for Light Metal Plate Connected Wood Trusses (Limit States Design)	9.23.14.11.(6)
UL	ANSI/UL 300-2005	Fire Testing of Fire Extinguishing Systems for Protection of Commercial Cooking Equipment	6.2.2.7.(2)
UL	731-1995	Oil-Fired Unit Heaters	Table 9.36.3.10.

Table 1.3.1.2. (Continued)

Issuing Agency	Document Number <sup>(1)(2)</sup>	Title of Document <sup>(3)</sup>	Code Reference
ULC	CAN/ULC-S101-07	Fire Endurance Tests of Building Construction and Materials	3.1.5.12.(3) 3.1.5.12.(4) 3.1.5.12.(6) 3.1.7.1.(1) 3.1.11.7.(1) 3.2.3.8.(1) 3.2.6.5.(6) 9.10.16.3.(1)
ULC	CAN/ULC-S102-10	Test for Surface Burning Characteristics of Building Materials and Assemblies	3.1.5.21.(1) 3.1.12.1.(1)
ULC	CAN/ULC-S102.2-10	Test for Surface Burning Characteristics of Flooring, Floor Coverings, and Miscellaneous Materials and Assemblies	3.1.12.1.(2) 3.1.13.4.(1)
ULC	CAN/ULC-S102.3-07	Fire Test of Light Diffusers and Lenses	3.1.13.4.(1)
ULC	CAN/ULC-S102.4-10	Test for Fire and Smoke Characteristics of Electrical Wiring, Cables and Non-Metallic Raceways	3.1.5.18.(2) 3.1.5.20.(2)
ULC	CAN/ULC-S104-10	Fire Tests of Door Assemblies	3.1.8.4.(1) 3.2.6.5.(3)
ULC	CAN/ULC-S105-09	Fire Door Frames Meeting the Performance Required by CAN/ULC-S104	9.10.13.6.(1)
ULC	CAN4-S106-M80	Fire Tests of Window and Glass Block Assemblies	3.1.8.4.(1)
ULC	CAN/ULC-S107-10	Fire Tests of Roof Coverings	3.1.15.1.(1)
ULC	CAN/ULC-S109-03	Flame Tests of Flame-Resistant Fabrics and Films	3.1.6.5.(1) 3.1.16.1.(1) 3.6.5.2.(2) 3.6.5.3.(1) 9.33.6.3.(1)
ULC	CAN/ULC-S110-07	Test for Air Ducts	3.6.5.1.(2) 3.6.5.1.(5) 9.33.6.2.(2) 9.33.6.2.(4)
ULC	ULC-S111-07	Fire Tests for Air Filter Units	6.2.3.13.(1) 9.33.6.14.(1)
ULC	CAN/ULC-S112-10	Fire Test of Fire Damper Assemblies	3.1.8.4.(1)
ULC	CAN/ULC-S112.1-10	Leakage Rated Dampers for Use in Smoke Control Systems	6.2.3.9.(3)
ULC	CAN/ULC-S113-07	Wood Core Doors Meeting the Performance Required by CAN/ULC-S104 for Twenty Minute Fire Rated Closure Assemblies	9.10.13.2.(1)
ULC	CAN/ULC-S114-05	Test for Determination of Non-Combustibility in Building Materials	1.4.1.2.(1) <sup>(4)</sup>
ULC	CAN/ULC-S115-11	Fire Tests of Firestop Systems	3.1.5.16.(3) 3.1.9.1.(1) 3.1.9.1.(2) 3.1.9.1.(3) 3.1.9.4.(4) 9.10.9.6.(2) 9.10.9.7.(3)
ULC	CAN/ULC-S124-06	Test for the Evaluation of Protective Coverings for Foamed Plastic	3.1.5.12.(2)
ULC	CAN/ULC-S126-06	Test for Fire Spread Under Roof-Deck Assemblies	3.1.14.1.(1) 3.1.14.2.(1)
ULC	CAN/ULC-S134-92	Fire Test of Exterior Wall Assemblies	3.1.5.5.(1) 3.2.3.7.(3) 9.10.14.5.(2) 9.10.15.5.(2) 9.10.15.5.(3)

**Table 1.3.1.2. (Continued)**

Issuing Agency	Document Number <sup>(1)(2)</sup>	Title of Document <sup>(3)</sup>	Code Reference
ULC	ULC-S135-04	Test Method for the Determination of Combustibility Parameters of Building Materials Using an Oxygen Consumption Calorimeter (Cone Calorimeter)	3.1.5.1.(2)
ULC	CAN/ULC-S138-06	Test for Fire Growth of Insulated Building Panels in a Full-Scale Room Configuration	3.1.5.12.(7)
ULC	ULC-S139-00	Fire Test for Evaluation of Integrity of Electrical Cables	3.2.7.10.(2) 3.2.7.10.(3)
ULC	CAN/ULC-S143-09	Fire Tests for Non-Metallic Electrical and Optical Fibre Cable Raceway Systems	3.1.5.20.(1)
ULC	ULC-S505-1974	Fusible Links for Fire Protection Service	3.1.8.9.(1)
ULC	CAN/ULC-S524-06	Installation of Fire Alarm Systems	3.1.8.12.(2) 3.1.8.12.(3) 3.2.4.5.(1) 3.2.4.21.(7) 3.2.4.21.(12) 9.10.19.4.(3) 9.10.19.6.(2)
ULC	CAN/ULC-S531-02	Smoke-Alarms	3.2.4.21.(1) 9.10.19.1.(1)
ULC	CAN/ULC-S537-04	Verification of Fire Alarm Systems	3.2.4.5.(2)
ULC	CAN/ULC-S553-02	Installation of Smoke-Alarms	3.2.4.21.(10) 9.10.19.3.(2)
ULC	CAN/ULC-S561-03	Installation and Services for Fire Signal Receiving Centres and Systems	3.2.4.8.(4)
ULC	CAN/ULC-S572-10	Photoluminescent and Self-Luminous Signs and Path Marking Systems	3.4.5.1.(3) 3.4.5.1.(4) 9.9.11.3.(3) 9.9.11.3.(4)
ULC	CAN/ULC-S610-M87	Factory-Built Fireplaces	9.22.8.1.(1)
ULC	ULC-S628-93	Fireplace Inserts	9.22.10.1.(1)
ULC	CAN/ULC-S629-M87	650°C Factory-Built Chimneys	9.33.10.2.(1)
ULC	CAN/ULC-S639-M87	Steel Liner Assemblies for Solid-Fuel Burning Masonry Fireplaces	9.22.2.3.(1)
ULC	CAN/ULC-S701-11	Thermal Insulation, Polystyrene, Boards and Pipe Covering	Table 5.10.1.1. 9.15.4.1.(1) Table 9.23.17.2.A. 9.25.2.2.(1)
ULC	CAN/ULC-S702-09	Mineral Fibre Thermal Insulation for Buildings	Table 5.10.1.1. Table 9.23.17.2.A. 9.25.2.2.(1)
ULC	CAN/ULC-S703-09	Cellulose Fibre Insulation for Buildings	Table 5.10.1.1. 9.25.2.2.(1)
ULC	CAN/ULC-S704-11	Thermal Insulation, Polyurethane and Polyisocyanurate, Boards, Faced	Table 5.10.1.1. Table 9.23.17.2.A. 9.25.2.2.(1)
ULC	CAN/ULC-S705.1-01	Thermal Insulation – Spray Applied Rigid Polyurethane Foam, Medium Density – Material - Specification	Table 5.10.1.1. 9.25.2.2.(1)
ULC	CAN/ULC-S705.2-05	Thermal Insulation – Spray-Applied Rigid Polyurethane Foam, Medium Density – Application	5.3.1.3.(3) Table 5.10.1.1. 9.25.2.5.(1)

Table 1.3.1.2. (Continued)

Issuing Agency	Document Number <sup>(1)(2)</sup>	Title of Document <sup>(3)</sup>	Code Reference
ULC	CAN/ULC-S706-09	Wood Fibre Insulating Boards for Buildings	Table 5.10.1.1. 9.23.16.7.(3) Table 9.23.17.2.A. 9.25.2.2.(1) 9.29.8.1.(1)
ULC	CAN/ULC-S710.1-05	Thermal Insulation – Bead-Applied One Component Polyurethane Air Sealant Foam, Part 1: Material Specification	9.36.2.10.(6)
ULC	CAN/ULC-S711.1-05	Thermal Insulation – Bead-Applied Two Component Polyurethane Air Sealant Foam, Part 1: Material Specification	9.36.2.10.(6)
ULC	CAN/ULC-S741-08	Air Barrier Materials – Specification	5.4.1.2.(1) 9.36.2.10.(1)
ULC	CAN/ULC-S742-11	Air Barrier Assemblies – Specification	9.36.2.9.(1)
ULC	ULC/ORD-C199P-2002	Combustible Piping for Sprinkler Systems	3.2.5.13.(2) 3.2.5.13.(5)
ULC	ULC/ORD-C1254.6-1995	Fire Testing of Restaurant Cooking Area Fire Extinguishing System Units	6.2.2.7.(2)
US Congress		National Appliance Energy Conservation Act of 1987	Table 9.36.4.2. Table 9.36.5.16.

**Notes to Table 1.3.1.2.:**

- (1) Some documents may have been reaffirmed or reapproved. Check with the applicable issuing agency for up-to-date information.
- (2) Some documents referenced in the energy efficiency provisions in Section 9.36. were published after the date specified in Sentence 1.3.1.1.(1).
- (3) Some titles have been abridged to omit superfluous wording.
- (4) Code reference is in Division A.
- (5) Notwithstanding the effective date stated in Sentence 1.3.1.1.(1), the 2013 edition of NFPA 13 is referenced as it better meets the intent of the Code.

**1.3.2. Organizations****1.3.2.1. Abbreviations of Proper Names**

**1)** The abbreviations of proper names in this Code shall have the meanings assigned to them in this Article (the appropriate addresses of the organizations are shown in brackets).

- ACGIH ..... American Conference of Governmental Industrial Hygienists  
(1330 Kemper Meadow Drive, Cincinnati, Ohio 45240-1634 U.S.A.;  
www.acgih.org)
- AHAM ..... Association of Home Appliance Manufacturers (111 19th Street, NW,  
Suite 402, Washington, D.C. 20036 U.S.A.; www.aham.org)
- AHRI ..... Air-Conditioning, Heating and Refrigeration Institute (2111  
Wilson Boulevard, Suite 500, Arlington, Virginia 22201 U.S.A.;  
www.ahrinet.org)
- AISI ..... American Iron and Steel Institute (1140 Connecticut Avenue, NW,  
Suite 705, Washington, D.C. 20036 U.S.A.; www.steel.org)
- ANSI ..... American National Standards Institute (25 West 43rd Street, 4th Floor,  
New York, New York 10036 U.S.A.; www.ansi.org)
- ASCE ..... American Society of Civil Engineers (1801 Alexander Bell Drive,  
Reston, Virginia 20191 U.S.A.; www.asce.org)
- ASHRAE ..... American Society of Heating, Refrigerating and Air-Conditioning  
Engineers (1791 Tullie Circle, N.E., Atlanta, Georgia 30329 U.S.A.;  
www.ashrae.org)
- ASME ..... American Society of Mechanical Engineers (Three Park Avenue, New  
York, New York 10016-5990 U.S.A.; www.asme.org)



- ASTM ..... American Society for Testing and Materials International (100 Barr Harbor Drive, West Conshohocken, Pennsylvania 19428-2959 U.S.A.; [www.astm.org](http://www.astm.org))
- AWPA ..... American Wood Protection Association (P.O. Box 361784, Birmingham, Alabama 35236-1784 U.S.A.; [www.awpa.com](http://www.awpa.com))
- BIA ..... Brick Industry Association (1850 Centennial Park Drive, Suite 301, Reston, Virginia 20191 U.S.A.; [www.bia.org](http://www.bia.org))
- BNQ ..... Bureau de normalisation du Québec (333, rue Franquet, Québec (Québec) G1P 4C7; [www.bnq.qc.ca](http://www.bnq.qc.ca))
- CAN ..... National Standard of Canada designation. (The number or name following the CAN designation represents the agency under whose auspices the standard is issued. CAN3 designates CSA, and CAN4 designates ULC.)
- CCBFC ..... Canadian Commission on Building and Fire Codes (National Research Council of Canada, Ottawa, Ontario K1A 0R6; [www.nationalcodes.ca](http://www.nationalcodes.ca))
- CGSB ..... Canadian General Standards Board (Place du Portage, Phase III, 6B1, 11 Laurier Street, Gatineau, Quebec K1A 1G6; [www.pwgsc.gc.ca/cgsb](http://www.pwgsc.gc.ca/cgsb))
- CHC ..... Canadian Hydronics Council (295 The West Mall, Suite 330, Toronto, Ontario M9C 4Z4; [www.ciph.com](http://www.ciph.com))
- CISC ..... Canadian Institute of Steel Construction (3760 14th Avenue, Suite 200, Markham, Ontario L3R 3T7; [www.cisc.ca](http://www.cisc.ca))
- CMHC ..... Canada Mortgage and Housing Corporation (700 Montreal Road, Ottawa, Ontario K1A 0P7; [www.cmhc.ca](http://www.cmhc.ca))
- CRCA ..... Canadian Roofing Contractors' Association (2430 Don Reid Drive, Suite 100, Ottawa, Ontario K1H 1E1; [www.roofingcanada.com](http://www.roofingcanada.com))
- CSA ..... CSA Group (5060 Spectrum Way, Suite 100, Mississauga, Ontario L4W 5N6; [www.csagroup.ca](http://www.csagroup.ca))
- CTI ..... Cooling Technology Institute (P.O. Box 73383, Houston, Texas 77273-3383 U.S.A.; [www.cti.org](http://www.cti.org))
- CWC ..... Canadian Wood Council (99 Bank Street, Suite 400, Ottawa, Ontario K1P 6B9; [www.cwc.ca](http://www.cwc.ca))
- DOE ..... Department of Energy (1000 Independence Avenue, SW, Washington, D.C. 20585 U.S.A.; <http://energy.gov>)
- EC ..... Environment Canada (351 St. Joseph Boulevard, Vincent Massey Place, 8th Floor, Gatineau, Quebec K1A 0H3; [www.ec.gc.ca](http://www.ec.gc.ca))
- EPA ..... Environmental Protection Agency (1200 Pennsylvania Avenue NW, Washington, D.C. 20460 U.S.A.; [www.epa.gov](http://www.epa.gov))
- FPI ..... FPIInnovations – Wood Products (formerly FCC – Forintek Canada Corporation) (319, rue Franquet, Québec (Québec) G1P 4R4; [www.forintek.ca](http://www.forintek.ca))
- HC ..... Health Canada (Address Locator 0900C2, Ottawa, Ontario K1A 0K9; [www.hc-sc.gc.ca](http://www.hc-sc.gc.ca))
- HI ..... Hydronics Institute (35 Russo Place, Berkley Heights, New Jersey 07922 U.S.A.; [www.gamanet.org](http://www.gamanet.org))
- HRAI ..... Heating, Refrigeration and Air Conditioning Institute of Canada (2800 Skymark Avenue, Building 1, Suite 201, Mississauga, Ontario L4W 5A6; [www.hrai.ca](http://www.hrai.ca))
- HVI ..... Home Ventilating Institute (1000 N. Rand Road, Suite 214, Wauconda, Illinois 60084 U.S.A.; [www.hvi.org](http://www.hvi.org))
- ICC ..... International Code Council (500 New Jersey Avenue, NW, 6th Floor, Washington, D.C. 20001 U.S.A.; [www.iccsafe.org](http://www.iccsafe.org))

ISO .....	International Organization for Standardization (Standards Council of Canada, 270 Albert Street, Suite 200, Ottawa, Ontario K1P 6N7; <a href="http://www.iso.org">www.iso.org</a> )
NBC .....	National Building Code of Canada 2010 (see CCBFC)
NCMA .....	National Concrete Masonry Association (13750 Sunrise Valley Drive, Herndon, Virginia 20171-4662 U.S.A.; <a href="http://www.ncma.org">www.ncma.org</a> )
NECB .....	National Energy Code of Canada for Buildings 2011 (see CCBFC)
NFC .....	National Fire Code of Canada 2010 (see CCBFC)
NFPA .....	National Fire Protection Association (1 Batterymarch Park, Quincy, Massachusetts 02169-7471 U.S.A.; <a href="http://www.nfpa.org">www.nfpa.org</a> )
NFRC .....	National Fenestration Rating Council (6305 Ivy Lane, Suite 140, Greenbelt, Maryland 20770 U.S.A.; <a href="http://www.nfrc.org">www.nfrc.org</a> )
NLGA .....	National Lumber Grades Authority (#302-960 Quayside Drive, New Westminster, British Columbia V3M 6G2; <a href="http://www.nlga.org">www.nlga.org</a> )
NRC .....	National Research Council of Canada (Ottawa, Ontario K1A 0R6; <a href="http://www.nrc-cnrc.gc.ca">www.nrc-cnrc.gc.ca</a> )
NRCA .....	National Roofing Contractors Association (10255 W. Higgins Road, Suite 600, Rosemont, Illinois 60018-5607 U.S.A.; <a href="http://www.nrca.net">www.nrca.net</a> )
NRC-IRC .....	Institute for Research in Construction (National Research Council of Canada, Ottawa, Ontario K1A 0R6; <a href="http://irc.nrc-cnrc.gc.ca">irc.nrc-cnrc.gc.ca</a> )
NYCDH .....	New York City Department of Health and Mental Hygiene (Environmental and Occupational Disease Epidemiology, 253 Broadway, Suite 402, CN-34C, New York, New York 10007-2333 U.S.A.; <a href="http://www.nyc.gov/html/doh">www.nyc.gov/html/doh</a> )
OMMAH .....	Ontario Ministry of Municipal Affairs and Housing (777 Bay Street, 2nd Floor, Toronto, Ontario M5G 2E5; <a href="http://www.ontario.ca/buildingcode">www.ontario.ca/buildingcode</a> )
SMACNA .....	Sheet Metal and Air Conditioning Contractors' National Association (4201 Lafayette Center Drive, Chantilly, Virginia 20151-1219 U.S.A.; <a href="http://www.smacna.org">www.smacna.org</a> )
TC .....	Transport Canada (330 Sparks Street, Ottawa, Ontario K1A 0N5; <a href="http://www.tc.gc.ca">www.tc.gc.ca</a> )
TPIC .....	Truss Plate Institute of Canada (c/o MiTek Canada Inc., 100 Industrial Road, Bradford, Ontario L3Z 3G7; <a href="http://www.tpic.ca">www.tpic.ca</a> )
TWC .....	Tarion Warranty Corporation (formerly Ontario New Home Warranty Program) (5150 Yonge Street, Concourse Level, Toronto, Ontario M2N 6L8; <a href="http://www.tarion.com">www.tarion.com</a> )
UL .....	Underwriters Laboratories Inc. (333 Pfingsten Road, Northbrook, Illinois 60062-2096 U.S.A.; <a href="http://www.ul.com">www.ul.com</a> )
ULC .....	Underwriters' Laboratories of Canada (7 Underwriters Road, Toronto, Ontario M1R 3B4; <a href="http://www.ulc.ca">www.ulc.ca</a> )
WCLIB .....	West Coast Lumber Inspection Bureau (P.O. Box 23145, Portland, Oregon 97281 U.S.A.; <a href="http://www.wclib.org">www.wclib.org</a> )
WWPA .....	Western Wood Products Association (522 SW Fifth Avenue, Suite 500, Portland, Oregon 97204-2122 U.S.A.; <a href="http://www.wwpa.org">www.wwpa.org</a> )

**Table 5.10.1.1. (Continued)**

Issuing Agency	Document Number	Title of Document
CGSB	41-GP-6M	Sheets, Thermosetting Polyester Plastics, Glass Fiber Reinforced
CGSB	CAN/CGSB-41.24	Rigid Vinyl Siding, Soffits and Fascia
CGSB	CAN/CGSB-51.32-M	Sheathing, Membrane, Breather Type
CGSB	CAN/CGSB-51.33-M	Vapour Barrier Sheet, Excluding Polyethylene, for Use in Building Construction
CGSB	CAN/CGSB-51.34-M	Vapour Barrier, Polyethylene Sheet for Use in Building Construction
CGSB	CAN/CGSB-93.1-M	Sheet, Aluminum Alloy, Prefinished, Residential
CGSB	CAN/CGSB-93.2-M	Prefinished Aluminum Siding, Soffits and Fascia, for Residential Use
CGSB	CAN/CGSB-93.3-M	Prefinished Galvanized and Aluminum-Zinc Alloy Steel Sheet for Residential Use
CGSB	CAN/CGSB-93.4	Galvanized Steel and Aluminum-Zinc Alloy Coated Steel Siding, Soffits and Fascia, Prefinished, Residential
CSA	A23.1	Concrete Materials and Methods of Concrete Construction
CSA	CAN/CSA-A82.1-M	Burned Clay Brick (Solid Masonry Units Made from Clay or Shale)
CSA	A82.4-M	Structural Clay Load-Bearing Wall Tile
CSA	A82.5-M	Structural Clay Non-Load-Bearing Tile
CSA	CAN3-A82.8-M	Hollow Clay Brick
CSA	CAN/CSA-A82.27-M	Gypsum Board
CSA	A82.30-M	Interior Furring, Lathing and Gypsum Plastering
CSA	A82.31-M	Gypsum Board Application
CSA	CAN3-A93-M	Natural Airflow Ventilators for Buildings
CSA	A123.1/A123.5	Asphalt Shingles Made From Organic Felt and Surfaced with Mineral Granules/Asphalt Shingles Made From Glass Felt and Surfaced with Mineral Granules
CSA	CAN/CSA-A123.2	Asphalt-Coated Roofing Sheets
CSA	A123.3	Asphalt Saturated Organic Roofing Felt
CSA	CAN/CSA-A123.4	Asphalt for Constructing Built-Up Roof Coverings and Waterproofing Systems
CSA	A123.17	Asphalt Glass Felt Used in Roofing and Waterproofing
CSA	CAN3-A123.51-M	Asphalt Shingle Application on Roof Slopes 1:3 and Steeper
CSA	CAN3-A123.52-M	Asphalt Shingle Application on Roof Slopes 1:6 to Less Than 1:3
CSA	CAN/CSA-A165.1	Concrete Block Masonry Units
CSA	CAN/CSA-A165.2	Concrete Brick Masonry Units
CSA	CAN/CSA-A165.3	Prefaced Concrete Masonry Units
CSA	CAN3-A165.4-M	Autoclaved Cellular Units
CSA	CAN/CSA-A179	Mortar and Grout for Unit Masonry
CSA	CAN/CSA-A220 Series	Concrete Roof Tiles
CSA	CAN/CSA-A371	Masonry Construction for Buildings
CSA	CAN/CSA-A3001	Cementitious Materials for Use in Concrete
CSA	CAN/CSA-B182.1	Plastic Drain and Sewer Pipe and Pipe Fittings
CSA	CAN/CSA-G40.21	General Requirements for Rolled or Welded Structural Quality Steel
CSA	CAN/CSA-G401	Corrugated Steel Pipe Products

Table 5.10.1.1. (Continued)

Issuing Agency	Document Number	Title of Document
CSA	CAN/CSA-O80 Series	Wood Preservation
CSA	O115-M	Hardwood and Decorative Plywood
CSA	O118.1	Western Red Cedar Shakes and Shingles
CSA	O118.2	Eastern White Cedar Shingles
CSA	O121	Douglas Fir Plywood
CSA	O141	Softwood Lumber
CSA	O151	Canadian Softwood Plywood
CSA	O153-M	Poplar Plywood
CSA	CAN/CSA-O325	Construction Sheathing
CSA	O437.0	OSB and Waferboard
ULC	CAN/ULC-S701	Thermal Insulation, Polystyrene, Boards and Pipe Covering
ULC	CAN/ULC-S702	Mineral Fibre Thermal Insulation for Buildings
ULC	CAN/ULC-S703	Cellulose Fibre Insulation (CFI) for Buildings
ULC	CAN/ULC-S704	Thermal Insulation, Polyurethane and Polyisocyanurate, Boards, Faced
ULC	CAN/ULC-S705.1	Thermal Insulation – Spray Applied Rigid Polyurethane Foam, Medium Density – Material - Specification
ULC	CAN/ULC-S705.2	Thermal Insulation – Spray-Applied Rigid Polyurethane Foam, Medium Density – Application
ULC	CAN/ULC-S706	Wood Fibre Thermal Insulation for Buildings

**Notes to Table 5.10.1.1.:**

(1) See Appendix A.

**5.10.2. Windows, Doors and Skylights****5.10.2.1. General**

**1)** This Subsection applies to windows, doors and skylights, including their components, that separate

- a) interior space from exterior space, or
- b) environmentally dissimilar interior spaces.

**2)** For the purpose of this Subsection, the term “skylight” refers to unit skylights, roof windows and tubular daylighting devices.

**3)** Where a wired glass assembly is installed in a required *fire separation*, it need not conform to the requirements of this Subsection. (See Appendix A.)

**5.10.2.2. Applicable Standards**

(See Appendix A.)

**1)** Windows, doors and skylights shall conform to the requirements in

- a) AAMA/WDMA/CSA 101/I.S.2/A440, “NAFS – North American Fenestration Standard/Specification for Windows, Doors, and Skylights,” and
- b) CSA A440S1, “Canadian Supplement to AAMA/WDMA/CSA 101/I.S.2/A440, NAFS – North American Fenestration Standard/Specification for Windows, Doors, and Skylights.”

**2)** Performance grades for windows, doors and skylights shall be selected according to the Canadian Supplement referenced in Clause (1)(b) so as to be

# **Part 6**

## **Heating, Ventilating and Air-conditioning**

### **Section 6.1. General**

#### **6.1.1. Application**

##### **6.1.1.1. Scope**

- 1) The scope of this Part shall be as described in Subsection 1.3.3. of Division A.

##### **6.1.1.2. Application**

- 1) This Part applies to systems and equipment for heating, ventilating and air-conditioning services.

#### **6.1.2. Definitions**

##### **6.1.2.1. Defined Terms**

- 1) Words that appear in italics are defined in Article 1.4.1.2. of Division A.

#### **6.1.3. Plans and Specifications**

##### **6.1.3.1. Required Plans and Specifications**

- 1) Plans, specifications and other information for heating, ventilating and air-conditioning systems shall conform to Subsection 2.2.6. of Division C.

### **Section 6.2. Design and Installation**

#### **6.2.1. General**

##### **6.2.1.1. Good Engineering Practice**

(See Appendix A.)

- 1) Heating, ventilating and air-conditioning systems, including mechanical refrigeration equipment, shall be designed, constructed and installed in conformance with good engineering practice such as that described in, but not limited to,
  - a) the ASHRAE Handbooks and Standards,
  - b) the HRAI Digest,
  - c) the Hydronics Institute Manuals,
  - d) the NFPA Standards,
  - e) the SMACNA Manuals,
  - f) the Industrial Ventilation Manual published by the ACGIH,
  - g) CSA B214, "Installation Code for Hydronic Heating Systems,"
  - h) CAN/CSA-Z317.2, "Special Requirements for Heating, Ventilation, and Air-Conditioning (HVAC) Systems in Health Care Facilities,"
  - i) EPA 625/R-92/016, "Radon Prevention in the Design and Construction of Schools and Other Large Buildings."

**6.2.1.2. Fire Safety Requirements**

- 1) The fire safety characteristics of heating, ventilating and air-conditioning systems shall comply with Subsection 3.6.5.
- 2) Characteristics referred to in Sentence (1) include but are not limited to
  - a) use of *combustible* materials in duct systems,
  - b) *flame-spread ratings* and smoke-developed ratings of duct and pipe materials and coverings,
  - c) installation of equipment relative to property lines, and
  - d) requirements for *fire dampers* and *fire stop flaps*.

**6.2.1.3. Structural Movement**

(See Appendix A.)

- 1) Mechanical systems and equipment shall be designed and installed to accommodate the maximum relative structural movement provided for in the construction of the *building*. (See Sentence 4.1.3.3.(2), Article 4.1.3.5. and Subsection 4.1.8. for information on the types of structural movements that may be encountered.)

**6.2.1.4. Installation Standards**

- 1) Except as provided in Articles 6.2.1.5. and 6.2.1.6., the installation of heating and air-conditioning equipment, including mechanical refrigeration equipment, and including provisions for mounting, clearances and air supply, shall conform to appropriate provincial or territorial requirements or, in the absence of such requirements, to the requirements of
  - a) CSA B51, "Boiler, Pressure Vessel, and Pressure Piping Code,"
  - b) CSA B52, "Mechanical Refrigeration Code,"
  - c) CSA B139, "Installation Code for Oil-Burning Equipment,"
  - d) CSA B149.1, "Natural Gas and Propane Installation Code,"
  - e) CSA B365, "Installation Code for Solid-Fuel-Burning Appliances and Equipment," or
  - f) CSA C22.1, "Canadian Electrical Code, Part I."

**6.2.1.5. Fireplaces**

- 1) Fireplaces shall conform to the requirements of Section 9.22.

**6.2.1.6. Heat Recovery Ventilators**

- 1) Heat recovery ventilators with rated capacities of not less than 25 L/s and not more than 200 L/s shall be installed in accordance with Subsection 9.32.3.

**6.2.1.7. Outdoor Design Conditions**

- 1) The outdoor conditions to be used in designing heating, ventilating and air-conditioning systems shall be determined in conformance with Subsection 1.1.3.
  - 2) Except as provided in Sentence 6.2.2.4.(1), the outdoor air quality conditions of the geographic area of the *building* site to be used in designing ventilation systems shall conform to appropriate provincial or territorial requirements or, in the absence of such requirements, shall be equal to or less than the maximum acceptable levels stated in the National Ambient Air Quality Objectives of the Canadian Environmental Protection Act as follows:
    - a) 70 µg/m<sup>3</sup> annually and 120 µg/m<sup>3</sup> daily for particulate matter that is 10 µm or less in diameter (PM<sub>10</sub>),
    - b) 15 ppb annually, 25 ppb daily, and 82 ppb hourly for ground-level ozone, and
    - c) 13 ppm (15 mg/m<sup>3</sup>) in eight hours and 30 ppm (35 mg/m<sup>3</sup>) hourly for carbon monoxide (CO), where 1 ppm = 1.146 mg CO/m<sup>3</sup>.
- (See Appendix A.)

**6.2.1.8. Installation – General**

- 1) Equipment requiring periodic maintenance and forming part of a heating, ventilating or air-conditioning system shall be installed with provision for access for inspection, maintenance, repair and cleaning. (See Appendix A.)
- 2) Mechanical equipment shall be provided with guards so as to prevent injury.
- 3) Heating, ventilating or air-conditioning systems shall be protected from freezing if they may be adversely affected by freezing temperatures.

**6.2.1.9. Expansion, Contraction and System Pressure**

- 1) Heating and cooling systems shall be designed to allow for expansion and contraction of the heat transfer fluid and to maintain the system pressure within the rated working pressure limits of all components of the system.

**6.2.1.10. Asbestos**

- 1) Asbestos shall not be used in air distribution systems or equipment in a form or in a location where asbestos fibres could enter the air supply or return systems.

**6.2.1.11. Access Openings**

- 1) Any covering of an access opening through which a person could enter shall be openable from the inside without the use of keys where there is a possibility of the opening being accidentally closed while the system or equipment is being serviced.

**6.2.2. Ventilation****6.2.2.1. Required Ventilation**

- 1) Except as provided in Sentence (3), all *buildings* shall be ventilated in accordance with this Part.
- 2) Except in *storage garages* covered by Article 6.2.2.3., the rates at which outdoor air is supplied in *buildings* by ventilation systems shall be not less than the rates required by ANSI/ASHRAE 62, "Ventilation for Acceptable Indoor Air Quality" (except Addendum n).
- 3) Self-contained mechanical ventilation systems serving only one *dwelling unit* shall comply with
  - a) this Part, or
  - b) Subsection 9.32.3.

**6.2.2.2. Natural Ventilation**

- 1) Except as permitted by Sentence (2), the ventilation required by Article 6.2.2.1. shall be provided by mechanical ventilation, except that it can be provided by natural ventilation or a combination of natural and mechanical ventilation in
  - a) *buildings* of other than *residential occupancy* having an *occupant load* of not more than one person per 40 m<sup>2</sup> during normal use,
  - b) *buildings of industrial occupancy* where the nature of the processes contained therein permits or requires the use of large openings in the *building* envelope even during the winter, and
  - c) seasonal *buildings* not intended to be occupied during the winter.
- 2) Where climatic conditions permit, *buildings* containing *occupancies* other than *residential occupancies* may be ventilated by natural ventilation methods in lieu of mechanical ventilation where engineering data demonstrates that such a method will provide the required ventilation for the type of *occupancy*.

**6.2.2.3. Ventilation of Storage Garages**

**1)** Except as provided in Sentences (4) and (6), an enclosed *storage garage* shall have a mechanical ventilation system designed to

- limit the concentration of carbon monoxide to not more than 100 parts per million parts of air,
- limit the concentration of nitrogen dioxide to not more than 3 parts per million parts of air, where the majority of the vehicles stored are powered by diesel-fuelled engines, or
- provide, during operating hours, a continuous supply of outdoor air at a rate of not less than 3.9 L/s for each square metre of *floor area* (see Article 3.3.1.20.).

(See also Sentence 3.3.5.4.(4).)

**2)** Mechanical ventilation systems provided in accordance with Clause (1)(a) shall be controlled by carbon monoxide monitoring devices, and systems provided in accordance with Clause (1)(b) shall be controlled by nitrogen dioxide or other acceptable monitoring devices. (See Appendix A.)

**3)** Mechanical ventilation systems provided in accordance with Sentence (1) shall be designed such that the pressure in the *storage garage* is less than the pressure in adjoining *buildings* of other *occupancy*, or in adjacent portions of the same *building* having a different *occupancy*.

**4)** In *storage garages* subject to the requirements of Sentences (1) and (2), where motor vehicles are parked by mechanical means, the ventilation requirements may be reduced by one half.

**5)** Except as provided in Sentence (6), ticket and attendant booths of *storage garages* shall be pressurized with a supply of uncontaminated air.

**6)** The requirements of Sentences (1) to (5) shall not apply to *open-air storeys* in a *storage garage*.

**6.2.2.4. Cleaning Devices**

**1)** Where outdoor air quality conditions do not meet the requirements of Sentence 6.2.1.7.(2), ventilation required by Sentence 6.2.2.1.(1) shall be provided by a ventilation system designed to include devices that reduce particles and gases to the maximum acceptable levels described in Sentence 6.2.1.7.(2) prior to the introduction of outdoor air to indoor occupied spaces.

**6.2.2.5. Air Contaminants**

**1)** Air contaminants released within *buildings* shall be removed insofar as possible at their points of origin and shall not be permitted to accumulate in concentrations greater than permitted in the Industrial Ventilation Manual published by the American Conference of Governmental Industrial Hygienists.

**2)** Systems serving spaces that contain sources of contamination and systems serving other occupied parts of the *building* but located in or running through spaces that contain sources of contamination shall be designed in such a manner as to prevent spreading of such contamination to other occupied parts of the *building*.

**3)** Heating, ventilating and air-conditioning systems shall be designed to minimize the growth of micro-organisms. (See Appendix A.)

**6.2.2.6. Hazardous Gases, Dusts or Liquids**

**1)** Except as provided in Subsection 6.2.12., systems serving spaces that contain hazardous gases, dusts or liquids shall be designed, constructed and installed to conform to the requirements of the applicable provincial or territorial regulations or municipal bylaws or, in the absence of such regulations or bylaws, to good engineering practice such as that described in the publications of the National Fire Protection Association and in the NFC. (See Appendix A.)



- b) be designed according to good engineering practice such as that provided in CWC 2009, "Engineering Guide for Wood Frame Construction," or
- c) be designed according to Part 4 using the loads and deflection and vibration limits specified in
  - i) Part 9, or
  - ii) Part 4.

**2)** Where floor framing is designed in accordance with Clause (1)(b) or (c), and where supporting wall framing and fastenings, or footings, are designed according to Clause (1)(a), the specified *live load* on the floor according to Table 4.1.5.3. shall not exceed 2.4 kPa.

**3)** Location-specific information for structural design, including snow and wind loads and seismic spectral response accelerations, shall be determined according to Subsection 1.1.3.

**9.4.2. Specified Loads**

**9.4.2.1. Application**

**1)** This Subsection applies to light-frame constructions whose wall, floor and roof planes are generally comprised of frames of small repetitive structural members, and where

- a) the roof and wall planes are clad, sheathed or braced on at least one side,
- b) the small repetitive structural members are spaced not more than 600 mm o.c.,
- c) the clear span of any structural member does not exceed 12.2 m,
- d) the maximum deflection of the structural roof members conforms to Article 9.4.3.1.,
- e) the maximum total roof area, notwithstanding any separation of adjoining *buildings* by *firewalls*, is 4 550 m<sup>2</sup>, and
- f) for flat roofs, there are no significant obstructions on the roof, such as parapet walls, spaced closer than the distance calculated by

$$D_o = 10 (H_o - 0.8S_s/\gamma)$$

where

- D<sub>o</sub> = minimum distance between obstructions, m,
- H<sub>o</sub> = height of the obstruction above the roof, m,
- S<sub>s</sub> = ground snow load, kPa, and
- γ = unit weight of snow, kN/m<sup>3</sup>.

**9.4.2.2. Specified Snow Loads**

(See Appendix A.)

**1)** Except as provided in Sentences (2) and (3), specified snow loads shall be not less than those calculated using the following formula:

$$S = C_b S_s + S_r$$

where

- S = specified snow load,
- C<sub>b</sub> = basic snow load roof factor, which is 0.45 where the entire width of the roof does not exceed 4.3 m and 0.55 for all other roofs,
- S<sub>s</sub> = 1-in-50-year ground snow load in kPa, determined according to Subsection 1.1.3., and
- S<sub>r</sub> = associated 1-in-50-year rain load in kPa, determined according to Subsection 1.1.3.

**2)** In no case shall the specified snow load be less than 1 kPa.

**3)** Bow string, arch or semi-circular roof trusses having an unsupported span greater than 6 m shall be designed in conformance with the snow load requirements in Subsection 4.1.6.

**9.4.2.3. Platforms Subject to Snow and Occupancy Loads**

**1)** Balconies, decks and other accessible exterior platforms intended for an *occupancy* and subject to snow loads shall be designed to carry the specified roof snow load or 1.9 kPa, whichever is greater, where the platform, or each segregated area of the platform, serves a single *dwelling unit*. (See Appendix A.)

**9.4.2.4. Attics and Roof Spaces**

**1)** The ceiling joists or truss bottom chords in residential *attic or roof spaces* having limited accessibility that precludes the storage of equipment or material shall be designed for a total specified load of not less than 0.35 kPa, where the total specified load is the sum of the specified *dead load* plus the specified *live load* of the ceiling. (See Appendix A.)

**9.4.3. Deflections**

**9.4.3.1. Deflections**

- 1)** The maximum deflection of structural members shall conform to Table 9.4.3.1.
- 2)** *Dead loads* need not be considered in computing deflections referred to in Sentence (1).

**Table 9.4.3.1.**  
**Maximum Deflections**  
Forming Part of Sentence 9.4.3.1.(1)

Structural Members	Type of Ceiling Supported	Max. Allowable Deflection as an Expressed Ratio of the Clear Span
Roof rafters, roof joists and roof beams	No ceiling	1/180
	Other than plaster or gypsum board	1/240
	Plaster or gypsum board	1/360
Ceiling joists	Other than plaster or gypsum board	1/240
	Plaster or gypsum board	1/360
Floor beams, floor joists and floor decking	All cases	1/360
Beams, joists and decking for balconies, decks and other accessible exterior platforms	Serving a single <i>dwelling unit</i>	1/240
	Other	1/360

**9.4.4. Foundation Conditions**

**9.4.4.1. Allowable Bearing Pressures**

- 1)** Footing sizes for *shallow foundations* shall be
  - a) determined in accordance with Section 9.15., or
  - b) designed in accordance with Section 4.2. using
    - i) the maximum allowable bearing pressures in Table 9.4.4.1., or
    - ii) allowable bearing pressures determined from *subsurface investigation*.

**9.23.4.5. Heavy Roofing Materials**

1) Where a roof is required to support an additional uniform *dead load* from roofing materials such as concrete roofing tile, or materials other than as specified in Section 9.27., such as clay roofing tiles, the additional load shall be allowed for by reducing

- a) the spans for roof joists and rafters in Tables A-4 to A-7, or the spacing of the members, and
- b) the spans for ridge beams and lintels in Tables A-12 to A-16.

(See A-9.23.4.2. in Appendix A.)

**9.23.5. Notching and Drilling****9.23.5.1. Holes Drilled in Framing Members**

1) Holes drilled in roof, floor or ceiling framing members shall be not larger than one-quarter the depth of the member and shall be located not less than 50 mm from the edges, unless the depth of the member is increased by the size of the hole.

**9.23.5.2. Notching of Framing Members**

1) Floor, roof and ceiling framing members are permitted to be notched provided the notch is located on the top of the member within half the joist depth from the edge of bearing and is not deeper than one-third the joist depth, unless the depth of the member is increased by the size of the notch.

**9.23.5.3. Wall Studs**

1) Wall studs shall not be notched, drilled or otherwise damaged so that the undamaged portion of the stud is less than two-thirds the depth of the stud if the stud is *loadbearing* or 40 mm if the stud is *non-loadbearing*, unless the weakened studs are suitably reinforced.

**9.23.5.4. Top Plates**

1) Top plates in walls shall not be notched, drilled or otherwise weakened to reduce the undamaged width to less than 50 mm unless the weakened plates are suitably reinforced.

**9.23.5.5. Roof Trusses**

1) Roof truss members shall not be notched, drilled or otherwise weakened unless such notching or drilling is allowed for in the design of the truss.

**9.23.6. Anchorage****9.23.6.1. Anchorage of Building Frames**

1) Except as required by Sentence 9.23.6.3.(1), *building* frames shall be anchored to the *foundation* unless a structural analysis of wind and earthquake pressures shows anchorage is not required.

- 2) Except as provided in Sentences (3) and (5), anchorage shall be provided by
  - a) embedding the ends of the first floor joists in concrete, or
  - b) fastening the sill plate to the *foundation* with not less than 12.7 mm diam anchor bolts spaced not more than 2.4 m o.c.

3) For *buildings* with 2 or more floors supported by frame walls that are in areas where the seismic spectral response acceleration,  $S_a(0.2)$ , is equal to or greater than 0.70 but not greater than 1.2 or the 1-in-50 hourly wind pressure is equal to or greater than 0.80 kPa but not greater than 1.20 kPa, anchorage shall be provided by fastening the

sill plate to the *foundation* with not less than two anchor bolts per *braced wall panel*, where all anchor bolts used are

- a) not less than 15.9 mm in diameter, located within 0.5 m of the end of the *foundation*, and spaced not more than 2.4 m o.c. or
- b) not less than 12.7 mm in diameter, located within 0.5 m of the end of the *foundation*, and spaced not more than 1.7 m o.c.

**4)** Anchor bolts referred to in Sentences (2) and (3) shall be

- a) fastened to the sill plate with nuts and washers,
- b) embedded not less than 100 mm in the *foundation*, and
- c) so designed that they may be tightened without withdrawing them from the *foundation*.

**5)** Where the seismic spectral response acceleration,  $S_a(0.2)$ , is greater than 1.2 or the 1-in-50 hourly wind pressure is equal to or greater than 1.2 kPa, anchorage shall be designed according to Part 4.

### 9.23.6.2. Anchorage of Columns and Posts

**1)** Except as provided in Sentences (2) and (3), exterior columns and posts shall be anchored to resist uplift and lateral movement.

**2)** Except as provided in Sentence (3), where columns or posts support balconies, decks, verandas or other exterior platforms, and the distance from finished ground to the underside of the joists is not more than 600 mm,

- a) the columns or posts shall be anchored to the *foundation* to resist uplift and lateral movement, or
- b) the supported joists or beams shall be directly anchored to the ground to resist uplift.

**3)** Anchorage is not required for platforms described in Sentence (2) that

- a) are not more than 1 *storey* in height,
- b) are not more than 55 m<sup>2</sup> in area,
- c) do not support a roof, and
- d) are not attached to another structure, unless it can be demonstrated that differential movement will not adversely affect the performance of the structure to which the platform is attached.

### 9.23.6.3. Anchorage of Smaller Buildings

**1)** *Buildings* not more than 4.3 m wide and not more than 1 *storey* in *building height* that are not anchored in accordance with Sentence 9.23.6.1.(1) shall be anchored in conformance with the requirements of CSA Z240.10.1, "Site Preparation, Foundation, and Anchorage of Manufactured Homes."

## 9.23.7. Sill Plates

### 9.23.7.1. Size of Sill Plates

**1)** Where sill plates provide bearing for the floor system, they shall be not less than 38 mm by 89 mm material.

### 9.23.7.2. Levelling and Sealing of Sill Plates

**1)** Sill plates shall be

- a) levelled by setting them on a full bed of mortar, or
  - b) laid directly on the *foundation* if the top of the *foundation* is level.
- (See also Article 9.23.2.3.)

**2)** The joint between the sill plate for exterior walls and the *foundation* shall be sealed in accordance with Subsection 9.25.3.

**9.23.16.3. Direction of Installation**

- 1) Plywood roof sheathing shall be installed with the surface grain at right angles to the roof framing.
- 2) OSB roof sheathing conforming to CAN/CSA-O325, "Construction Sheathing," or to O-1 and O-2 grades as specified in CSA O437.0, "OSB and Waferboard," shall be installed with the direction of face orientation at right angles to the roof framing members. (See A-9.23.15.4.(2) in Appendix A.)

**9.23.16.4. Joints in Panel-Type Sheathing**

- 1) Panel-type sheathing board shall be applied so that joints perpendicular to the roof ridge are staggered where
  - a) the sheathing is applied with the surface grain parallel to the roof ridge, and
  - b) the thickness of the sheathing is such that the edges are required to be supported.
- 2) A gap of not less than 2 mm shall be left between sheets of plywood, OSB or waferboard.

**9.23.16.5. Lumber Roof Sheathing**

- 1) Lumber roof sheathing shall not be more than 286 mm wide and shall be applied so that all ends are supported with end joints staggered.
- 2) Lumber roof sheathing shall be installed diagonally, where
  - a) the seismic spectral response acceleration,  $S_a(0.2)$ , is greater than 0.70 but not greater than 1.2, or
  - b) the 1-in-50 hourly wind pressure is equal to or greater than 0.80 kPa but less than 1.20 kPa.
- 3) Lumber roof sheathing shall be designed according to Part 4, where
  - a) the seismic spectral response acceleration,  $S_a(0.2)$ , is greater than 1.2, or
  - b) the 1-in-50 hourly wind pressure is equal to or greater than 1.20 kPa.

**9.23.16.6. Edge Support**

- 1) Where panel-type roof sheathing requires edge support, the support shall consist of metal H clips or not less than 38 mm by 38 mm blocking securely nailed between framing members.

**9.23.16.7. Thickness or Rating**

- 1) The thickness or rating of roof sheathing on a flat roof used as a walking deck shall conform to either Table 9.23.15.5.A. or Table 9.23.15.5.B. for subfloors.
- 2) The thickness or rating of roof sheathing on a roof not used as a walking deck shall conform to either Table 9.23.16.7.A. or Table 9.23.16.7.B.
- 3) Asphalt-coated or asphalt-impregnated fibreboard not less than 11.1 mm thick conforming to CAN/ULC-S706, "Wood Fibre Thermal Insulation for Buildings," is permitted to be used as a roof sheathing over supports spaced not more than 400 mm o.c. provided the roofing consists of
  - a) a continuous sheet of galvanized steel not less than 0.33 mm in thickness, or
  - b) a continuous sheet of aluminum not less than 0.61 mm in thickness.
- 4) All edges of sheathing described in Sentence (3) shall be supported by blocking or framing.

**Table 9.23.16.7.A.**  
**Thickness of Roof Sheathing**  
 Forming Part of Sentence 9.23.16.7.(2)

Maximum Spacing of Supports, mm	Minimum Thickness, mm				Lumber
	Plywood, and OSB, O-2 Grade		OSB, O-1 Grade, and Waferboard, R-1 Grade		
	Edges Supported	Edges Unsupported	Edges Supported	Edges Unsupported	
300	7.5	7.5	9.5	9.5	17.0
400	7.5	9.5	9.5	11.1	17.0
600	9.5	12.5	11.1	12.7	19.0

**Table 9.23.16.7.B.**  
**Rating for Roof Sheathing When Applying CAN/CSA-O325**  
 Forming Part of Sentence 9.23.16.7.(2)

Maximum Spacing of Supports, mm	Panel Mark	
	Edges Supported	Edges Unsupported
400	2R16	1R16
500	2R20	1R20
600	2R24	1R24

**9.23.17. Wall Sheathing**

**9.23.17.1. Required Sheathing**

**1)** Exterior walls and gable ends shall be sheathed when the exterior cladding requires intermediate fastening between supports or if the exterior cladding requires solid backing.

**9.23.17.2. Thickness, Rating and Material Standards**

**1)** Where wall sheathing is required for the purpose of complying with this Section, it shall conform to either Table 9.23.17.2.A. or 9.23.17.2.B. (See also Article 9.25.5.1.)

**9.26.2. Roofing Materials****9.26.2.1. Material Standards**

- 1)** Roofing materials shall conform to
  - a) CAN/CGSB-37.4-M, "Fibrated, Cutback Asphalt, Lap Cement for Asphalt Roofing,"
  - b) CAN/CGSB-37.5-M, "Cutback Asphalt Plastic, Cement,"
  - c) CAN/CGSB-37.8-M, "Asphalt, Cutback, Filled, for Roof Coating,"
  - d) CGSB 37-GP-9Ma, "Primer, Asphalt, Unfilled, for Asphalt Roofing, Dampproofing and Waterproofing,"
  - e) CGSB 37-GP-21M, "Tar, Cutback, Fibrated, for Roof Coating,"
  - f) CAN/CGSB-37.50-M, "Hot-Applied, Rubberized Asphalt for Roofing and Waterproofing,"
  - g) CGSB 37-GP-52M, "Roofing and Waterproofing Membrane, Sheet Applied, Elastomeric,"
  - h) CAN/CGSB-37.54, "Polyvinyl Chloride Roofing and Waterproofing Membrane,"
  - i) CGSB 37-GP-56M, "Membrane, Modified, Bituminous, Prefabricated, and Reinforced for Roofing,"
  - j) CGSB 41-GP-6M, "Sheets, Thermosetting Polyester Plastics, Glass Fiber Reinforced,"
  - k) CAN/CGSB-51.32-M, "Sheathing, Membrane, Breather Type,"
  - l) CSA A123.1/A123.5, "Asphalt Shingles Made From Organic Felt and Surfaced with Mineral Granules/Asphalt Shingles Made From Glass Felt and Surfaced with Mineral Granules,"
  - m) CAN/CSA-A123.2, "Asphalt-Coated Roofing Sheets,"
  - n) CSA A123.3, "Asphalt Saturated Organic Roofing Felt,"
  - o) CAN/CSA-A123.4, "Asphalt for Constructing Built-Up Roof Coverings and Waterproofing Systems,"
  - p) CSA A123.17, "Asphalt Glass Felt Used in Roofing and Waterproofing,"
  - q) CAN/CSA-A220 Series, "Concrete Roof Tiles,"
  - r) CSA O118.1, "Western Red Cedar Shakes and Shingles," or
  - s) CSA O118.2, "Eastern White Cedar Shingles."

**9.26.2.2. Nails**

- 1)** Nails used for roofing shall be corrosion-resistant roofing or shingle nails conforming to
  - a) ASTM F 1667, "Driven Fasteners: Nails, Spikes, and Staples," or
  - b) CSA B111, "Wire Nails, Spikes and Staples."
- 2)** Nails shall have sufficient length to penetrate through, or 12 mm into, roof sheathing.
- 3)** Nails used with asphalt roofing shall have a head diameter of not less than 9.5 mm and a shank thickness of not less than 2.95 mm.
- 4)** Nails used with wood shingles or shakes shall have a head diameter of not less than 4.8 mm and a shank thickness of not less than 2.0 mm and shall be stainless steel, aluminum or hot-dipped galvanized. (See Appendix A.)

**9.26.2.3. Staples**

- 1)** Staples used to apply asphalt or wood shingles shall be corrosion-resistant and shall be driven with the crown parallel to the eaves.
- 2)** Staples used with asphalt shingles shall be not less than 19 mm long, 1.6 mm diam or thickness, with not less than a 25 mm crown, except that an 11 mm crown may be used as provided in Sentence 9.26.7.4.(2).
- 3)** Staples used with wood shingles shall be not less than 29 mm long, 1.6 mm diam or thickness, with not less than a 9.5 mm crown and shall be stainless steel or aluminum. (See A-9.26.2.2.(4) in Appendix A.)

**9.26.3. Slope of Roofed Surfaces****9.26.3.1. Slope**

**1)** Except as provided in Sentences (2) and (3), the slopes on which roof coverings may be applied shall conform to Table 9.26.3.1.

**2)** Asphalt and gravel or coal tar and gravel roofs may be constructed with lower slopes than required in Sentence (1) when effective drainage is provided by roof drains located at the lowest points on the roofs.

**3)** Profiled metal roof cladding systems specifically designed for low-slope applications are permitted to be installed with lower slopes than required by Sentence (1), provided they are installed in conformance with the manufacturer's written recommendations.

**4)** Except where back-slope will not adversely affect adjacent supported or supporting constructions due to water ingress, roofs and constructions that effectively serve as roofs shall be constructed with sufficient slope away from

- a) exterior walls, and
- b) *guards* that are connected to the roof, or to a construction that effectively serves as a roof, by more than pickets or posts.

(See A-9.26.1.1.(2), A-9.26.4.1. and A-9.27.3.8.(4) in Appendix A.)

**5)** The slope required by Sentence (4) shall be sufficient to maintain a positive slope

- a) after expected shrinkage of the *building* frame, where these surfaces are supported by exterior walls and exterior columns (see A-9.27.3.8.(4) in Appendix A), and
- b) once design loading is taken into consideration, where these surfaces are cantilevered from exterior walls.



**9.26.13. Sheet Metal Roofing****9.26.13.1. Thickness**

- 1) Sheet metal roofing shall be not less than
  - a) 0.33 mm thick galvanized steel,
  - b) 0.46 mm thick copper,
  - c) 0.46 mm thick zinc, or
  - d) 0.48 mm thick aluminum.

**9.26.13.2. Support**

1) Except as provided in Sentence 9.23.16.1.(1), where sheet metal roofing is not supported by roof decking but spans between spaced supports, the panels shall be designed to support the specified *live loads* for roofs.

**9.26.14. Glass Reinforced Polyester Roofing****9.26.14.1. Support**

1) Except as provided in Sentence 9.23.16.1.(1), where glass-reinforced polyester roofing panels are not supported by roof decking but span between spaced supports, the panels shall be designed to support the specified live roof loads.

**9.26.15. Hot Applied Rubberized Asphalt Roofing****9.26.15.1. Installation**

1) Hot applied rubberized asphalt roofing shall be installed in accordance with CAN/CGSB-37.51-M, "Application for Hot-Applied Rubberized Asphalt for Roofing and Waterproofing."

**9.26.16. Polyvinyl Chloride Sheet Roofing****9.26.16.1. Installation**

1) Polyvinyl chloride sheet applied roofing membrane shall be installed in accordance with CGSB 37-GP-55M, "Application of Sheet Applied Flexible Polyvinyl Chloride Roofing Membrane."

**9.26.17. Concrete Roof Tiles****9.26.17.1. Installation**

1) Except as provided in Sentence 9.23.16.1.(1), concrete roof tiles shall be installed according to CAN/CSA-A220 Series, "Concrete Roof Tiles." (See Appendix A.)

**9.26.18. Roof Drains and Downspouts****9.26.18.1. Roof Drains**

- 1) When roof drains are provided they shall conform to Part 7.

**9.26.18.2. Downspouts**

1) Where downspouts are provided and are not connected to a sewer, extensions shall be provided to carry rainwater away from the *building* in a manner which will prevent *soil* erosion.

## Section 9.27. Cladding

### 9.27.1. Application

#### 9.27.1.1. General

- 1)** Where lumber, wood shingles, shakes, fibre-cement shingles, planks and sheets, plywood, OSB, waferboard, hardboard, vinyl, aluminum or steel, including trim and soffits, are installed as cladding on wood-frame walls exposed to precipitation, the cladding assembly shall comply with
  - a) Subsections 9.27.2. to 9.27.12., or
  - b) Part 5.
- 2)** Where stucco is installed as cladding on wood-frame or masonry walls exposed to precipitation, the cladding assembly shall comply with
  - a) Subsections 9.27.2. to 9.27.4., and Section 9.28., or
  - b) Part 5.
- 3)** Where masonry serves as cladding on wood-frame or masonry walls exposed to precipitation, the cladding assembly shall comply with
  - a) Subsections 9.27.2. to 9.27.4., and Section 9.20., or
  - b) Part 5.
- 4)** Where asphalt shingles are installed as cladding on wood-frame walls exposed to precipitation, the cladding assembly shall comply with
  - a) Subsections 9.26.7. and 9.27.2. to 9.27.4., or
  - b) Part 5.
- 5)** Where cladding materials other than those described in Sentences (1) to (4) are installed, or where the cladding materials described in Sentences (1) to (4) are installed on substrates other than those identified in Sentences (1) to (4), the materials and installation shall comply with Part 5.

### 9.27.2. Required Protection from Precipitation

(See Appendix A.)

#### 9.27.2.1. Minimizing and Preventing Ingress and Damage

- 1)** Except where exterior walls are protected from precipitation or where it can be shown that precipitation ingress will not adversely affect occupant health or safety, exterior walls shall be designed and constructed to
  - a) minimize the ingress of precipitation into the assembly, and
  - b) prevent the ingress of precipitation into interior space.(See Appendix A.)
- 2)** Except where exterior walls are protected from specific mechanisms of deterioration, such as mechanical impact and ultraviolet radiation, exterior walls shall be designed and constructed to minimize the likelihood of their required performance being reduced to an unacceptable level as a result of those mechanisms.

#### 9.27.2.2. Minimum Protection from Precipitation Ingress

(See Appendix A.)

- 1)** Except as provided in Sentence (2), a cladding assembly is deemed to have a capillary break between the cladding and the backing assembly, where
  - a) there is a drained and vented air space not less than 10 mm deep behind the cladding, over the full height and width of the wall (see also Article 9.27.5.3.),
  - b) an open drainage material, not less than 10 mm thick and with a cross-sectional area that is not less than 80% open, is installed between the cladding and the backing, over the full height and width of the wall,
  - c) the cladding is loosely fastened to the backing and behind each cladding component there is a clear air space that is
    - i) continuous for the full width of the component,

**9.36.4. Service Water Heating Systems**

**9.36.4.1. Scope and Application**

1) This Subsection is concerned with the efficient use of energy by systems used to heat service water for household use as well as for indoor pools and hot tubs.

2) Where service water heating equipment or techniques other than those described in this Subsection are used, the *building* shall be designed and constructed in accordance with the energy efficiency requirements of the NECB.

**9.36.4.2. Equipment Efficiency**

1) *Service water heaters, boilers*, pool heaters and storage tanks shall comply with the performance requirements stated in Table 9.36.4.2. (See Appendix A.)

2) Hot service water storage tanks not listed in Table 9.36.4.2. shall be covered with insulation having a minimum thermal resistance of 1.8 (m<sup>2</sup>·K)/W.

**Table 9.36.4.2.**  
**Service Water Heating Equipment Performance Standards**  
 Forming Part of Sentences 9.36.4.2.(1) and (2)

<b>Storage-Type Service Water Heaters</b>			
Component	Input <sup>(1)</sup>	Standard	Performance Requirement <sup>(2)</sup>
Electric	≤ 12 kW (50 L to 270 L capacity)	CAN/CSA-C191	SL ≤ 35 + 0.20V (top inlet)
			SL ≤ 40 + 0.20V (bottom inlet)
	≤ 12 kW (> 270 L and ≤ 454 L capacity)		SL ≤ (0.472V) – 38.5 (top inlet)
			SL ≤ (0.472V) – 33.5 (bottom inlet)
>12 kW (> 75 L capacity)	ANSI Z21.10.3/CSA 4.3 and DOE 10 CFR, Part 431, Subpart G	S = 0.30 + 27/V <sub>m</sub>	
Heat pump water heaters	≤ 24 A and ≤ 250 V	CAN/CSA-C745	EF ≥ 2.0
Gas-fired <sup>(3)</sup>	< 22 kW	CAN/CSA-P.3	EF ≥ 0.67 – 0.0005V
	≥ 22 kW	ANSI Z21.10.3/CSA 4.3	E <sub>t</sub> ≥ 80% and standby loss ≤ rated input <sup>(4)</sup> /(800 + 16.57·√V)
Oil-fired	≤ 30.5 kW	CAN/CSA-B211	EF ≥ 0.59 – 0.0005V
	> 30.5 kW	ANSI Z21.10.3/CSA 4.3 and DOE 10 CFR, Part 431, Subpart G	E <sub>t</sub> ≥ 78% and standby loss ≤ rated input <sup>(4)</sup> /(800 + 16.57·√V)
<b>Tankless Service Water Heaters</b>			
Component	Input <sup>(1)</sup>	Standard	Performance Requirement <sup>(2)</sup>
Gas-fired	≤ 73.2 kW	CAN/CSA-P.7	EF ≥ 0.8
	> 73.2 kW	ANSI Z21.10.3/CSA 4.3 and DOE 10 CFR, Part 431, Subpart G	E <sub>t</sub> ≥ 80%
Oil-fired	≤ 61.5 kW <sup>(5)</sup>	DOE 10 CFR, Part 430, Subpart B, Appendix E	EF ≥ 0.59 – 0.0019V <sub>m</sub>
	Other	ANSI Z21.10.3/CSA 4.3 and DOE 10 CFR, Part 431, Subpart G	E <sub>t</sub> ≥ 80%
Electric	—	—	(6)

Table 9.36.4.2. (Continued)

Tankless Service Water Heaters			
Component	Input <sup>(1)</sup>	Standard	Performance Requirement <sup>(2)</sup>
Combined space- and water-heating systems (combos)	≤ 87.9 kW if <i>boiler</i> -based	CAN/CSA-P.9	TPF = 0.65
	≤ 73.2 kW if based on <i>service water heater</i>		
Integrated mechanical systems	—	CSA P.10	OTPF = 0.78
Pool Heaters			
Component	Input <sup>(1)</sup>	Standard	Performance Requirement <sup>(2)</sup>
Gas-fired <sup>(3)</sup>	< 117.2 kW	ANSI Z21.56/CSA 4.7 or CSA P.6	$E_t \geq 82\%$
Oil-fired	—	CSA B140.12	$E_t \geq 75\%$

**Notes to Table 9.36.4.2.:**

(1) 1 kW = 3412 Btu/h

(2) The symbols and abbreviations used in this column have the following meanings:

- EF = energy factor, in %/h
- $E_t$  = thermal efficiency with 38.9°C water temperature difference
- OTPF = overall thermal performance factor
- S = standby loss, in %/h (percentage heat content of stored water per hour)
- SL = standby loss, in W
- TPF = thermal performance factor
- V = storage volume, in L, as specified by the manufacturer
- $V_m$  = measured storage volume, in US gallons

(3) Includes propane.

(4) Rated input is measured in watts.

(5) Consistent with the US Congress National Appliance Energy Conservation Act of 1987.

(6) No standard addresses the performance efficiency of electric tankless *service water heaters*; however, their efficiency typically approaches 100%.

**3)** Except for components that are required to be installed outdoors, service water heating equipment shall be installed in a *conditioned space*. (See Appendix A.)

**9.36.4.3. Solar Domestic Hot Water Systems**

**1)** Service water heating systems that use solar thermal technology shall conform to the manufacturer's design requirements and installation procedures.

**2)** Service water heating systems that use solar thermal technology shall be installed in accordance with the NPC.

**3)** Hot water storage tanks associated with the systems referred to in Sentence (2) shall be installed in a *conditioned space*.

**9.36.4.4. Piping**

**1)** The first 2 m of outlet piping downstream and of inlet piping upstream leading from a storage tank or heating vessel shall be covered with piping insulation that is at least 12 mm thick.

**2)** All piping forming part of a continuously operating recirculating service water heating system shall be covered with piping insulation that is at least 12 mm thick.

**3)** Where piping forming part of the service water heating system is located outside the *building* envelope or in an unconditioned space, it shall be insulated to a thermal resistance not less than the effective thermal resistance required for the exterior above-ground walls.

**9)** The airtightness value used in the energy model calculations for the proposed house shall be

- a) 3.2 air changes per hour at 50 Pa pressure differential, where the construction complies with Section 9.25.,
- b) 2.5 air changes per hour at 50 Pa pressure differential, where it can be shown that the *air barrier system* is constructed in accordance with Subsection 9.25.3. and Articles 9.36.2.9. and 9.36.2.10., or
- c) where airtightness is tested in accordance with Sentence (11),
  - i) the number of air changes per hour at 50 Pa pressure differential, and
  - ii) the equivalent leakage area (see Appendix A).

**10)** A design airtightness shall be assigned for use in the energy model calculations until the actual airtightness has been measured in accordance with Sentence (11).

**11)** Where measured airtightness is used in the energy model calculations, it shall be determined in accordance with CAN/CGSB-149.10, "Determination of the Airtightness of Building Envelopes by the Fan Depressurization Method,"

- a) as written, or
- b) excluding Clause 6.1.6, which allows intentional openings for mechanical equipment to be left unsealed.

(See Appendix A.)

**12)** Where airtightness is determined in accordance with Sentence (11) using air changes per hour, the result obtained at an air pressure differential of 50 Pa shall be used in the energy model calculations.

**13)** Where airtightness is determined in accordance with Clause (11)(b), its rate shall be adjusted in the energy model calculations to account for air leakage through mechanical equipment.

#### **9.36.5.11. Modeling HVAC System of Proposed House**

**1)** Where multiple HVAC systems serve a single space, the energy model calculations for the proposed house shall call each system in the order of priority established by the system control in the proposed house.

**2)** Where a heat pump is included in the proposed house, the energy model calculations shall include

- a) the effect of the source temperature on the heat pump's efficiency, and
- b) the temperature at which the heat pump shuts down.

**3)** Permanent supplementary heating systems that are operated by a thermostat or automatic control shall be included in the energy model calculations for the proposed house.

**4)** The performance characteristics of the heat-recovery ventilation system of the proposed house shall be as specified at not less than the principal ventilation rate required for a system designed in accordance with Section 9.32.

**5)** The ventilation system shall be modeled as operating 8 hours a day at the principal ventilation rate.

**6)** The energy model calculations shall determine the required principal ventilation rate, in L/s, in accordance with Article 9.32.3.3. based on the number of bedrooms in the proposed house.

**7)** The energy model calculations may include duct and piping losses, taking into account the properties of the specified duct and piping insulation of the proposed house.

**8)** The energy model calculations shall include a heating system and, where installed, a cooling system sized according to the specifications for the proposed house.

**9)** The energy model calculations shall include the effect of part-load performance of equipment using

- a) the same modeled part-load performance data used for the reference house as per Clause 9.36.5.15.(6)(a),

- b) the default part-load performance characteristics stated in Clause 9.36.5.15.(6)(b), or
  - c) measured data for the specified equipment.
- (See Appendix A.)

**10)** Where a heat-recovery ventilator is installed in the proposed house, the energy model calculations shall only account for the recovery of sensible heat using the efficiency ratings in Sentence 9.36.3.9.(3). (See Appendix A.)

**11)** Except as provided in Sentence (12), where a forced-air system is installed in the proposed house, the energy model calculations shall assume the circulation fan operates when the heating, cooling or principal ventilation system is operating. (See Appendix A.)

**12)** Where a forced-air system is installed in the proposed house and where the principal ventilation system in the proposed house is a separate, fully ducted ventilation system, the energy model calculations shall assume the circulation fan operates only when the heating or cooling system is operating.

**13)** Where the proposed house contains multiple HVAC systems, the circulation fan power shall be the sum of the circulation fan power capacity of each system.

**14)** The ventilation fan power consumption shall be modeled

- a) as being 2.32 W/L/s for each ventilation fan on the exhaust side and, where applicable, on the supply side, or
- b) as specified, where a heat-recovery ventilator is used.

**15)** Where a forced-air system is installed in the proposed house, the energy model calculations shall determine the flow rate, in L/s, of the circulation fan in the reference house by multiplying the capacity, in W, of the heating system in the proposed house by

- a) 0.0604 for heat pumps, and
- b) 0.0251 for all other types of heating systems.

**16)** Where a forced-air system is installed in the proposed house, the energy model calculations shall determine the minimum electricity requirement, in W, of the circulation fan by multiplying the flow rate, in L/s, of the circulation fan in the reference house, determined in accordance with Sentence (15), by a factor of 2.30.

**17)** Where a forced-air system is installed in the proposed house, the flow rate of the circulation fan shall be modeled as being the larger of

- a) the flow rate of the circulation fan of the reference house, determined in accordance with Sentence (15), or
- b) the flow rate of the circulation fan for the forced-air system specified in the design for the proposed house.

**18)** Except as provided in Sentence (19), where a forced-air system is installed in the proposed house, the power capacity of the circulation fan shall be modeled as specified in the design for the proposed house.

**19)** Where the design for the proposed house specifies a forced-air system with a circulation fan flow rate that is lower than that of the flow rate of the circulation fan in the reference house, as determined in accordance with Sentence (15), the electricity capacity, in W, of the circulation fan shall be modeled as being the larger of

- a) the electricity capacity specified for the circulation fan in the proposed forced-air system, or
- b) the minimum circulation fan electricity capacity determined in accordance with Sentence (16).

**20)** For natural gas-, oil-, propane- and wood-burning heating systems, the energy model calculations shall set the auxiliary electricity requirements, including that of combustion fans, to those specified for the proposed house.

### **9.36.5.12. Modeling Service Water Heating System of Proposed House**

**1)** The service water heating system used in the energy model calculations shall be sized as specified in the design for the proposed house.

**13)** Where a heat-recovery ventilator is required in the reference house in accordance with Article 9.36.3.8., the ventilation flow rate, in L/s, in the zone served by the pool or hot tub shall be multiplied by 4.18 W/L/s to determine the heat-recovery ventilator power, in W, to be used in the energy model calculations.

**14)** Where a forced-air system is installed in the reference house, the system's capacity, in W, shall be multiplied by one of the following factors to determine the circulation fan flow rate, in L/s:

- a) 0.0604 for heat pumps, and
- b) 0.0251 for all other types of heating systems.

**15)** Where a forced-air system is installed in the reference house, the circulation fan flow rate, in L/s, shall be multiplied by 2.30 W/L/s to determine the circulation fan power capacity, in W.

**16)** For natural gas-, oil-, propane- and wood-burning heating systems, the energy model calculations shall set the auxiliary electricity capacity, including that of combustion fans, to 208 W during operation.

**9.36.5.16. Modeling Service Water Heating System of Reference House**

**1)** The energy source of the reference house's service water heating system, which is gas, electricity, oil, propane, wood or a heat pump, shall be the same as that for the system in the proposed house.

**2)** The service water heating system in the reference house shall be sized in accordance with Subsection 9.31.6. with regard to output capacity.

**3)** Except as required by Table 9.36.5.16., the performance of the service water heating equipment in the reference house shall be modeled as conforming to Table 9.36.4.2. for the energy source, capacity and type of service water heating equipment in the proposed house.

**Table 9.36.5.16.**  
**Performance of Service Water Heating (SWH) Equipment in the Reference House**  
 Forming Part of Sentence 9.36.5.16.(3)

Type of SWH Equipment in Proposed House	Input for Proposed SWH Equipment	Type of SWH Equipment to be Used for Reference House	Input for Reference SWH Equipment
Gas-fired tankless <i>service water heater</i>	≤ 73.2 kW	Gas-fired storage type	≤ 22 kW
	> 73.2 kW		> 22 kW
Oil-fired tankless <i>service water heater</i>	≤ 61.5 kW <sup>(1)</sup>	Oil-fired storage type	≤ 30.5 kW <sup>(1)</sup>
	Other		> 30.5 kW
Not listed in Table 9.36.4.2.	—	Gas-fired storage type	≥ 22 kW (E <sub>t</sub> ≥ 80%)

**Notes to Table 9.36.5.16.:**

<sup>(1)</sup> Consistent with the US Congress National Appliance Energy Conservation Act of 1987.

**Section 9.37. Objectives and Functional Statements**

**9.37.1. Objectives and Functional Statements**

**9.37.1.1. Attributions to Acceptable Solutions**

**1)** For the purpose of compliance with this Code as required in Clause 1.2.1.1.(1)(b) of Division A, the objectives and functional statements attributed

to the acceptable solutions in this Part shall be the objectives and functional statements listed in Table 9.37.1.1. (See A-1.1.2.1.(1) in Appendix A.)

**Table 9.37.1.1.**

Table 9.37.1.1. is located in Volume 1, Attribution Tables.
---



# Appendix A

## Explanatory Material

### **A-1.1.2.1.(1) Objectives and Functional Statements Attributed to Acceptable**

**Solutions.** The objectives and functional statements attributed to each Code provision are shown in Tables at the end of Volume 1.

Many provisions in Division B serve as modifiers of or pointers to other provisions, or serve other clarification or explanatory purposes. In most cases, no objectives and functional statements have been attributed to such provisions, which therefore do not appear in the above-mentioned tables.

For provisions that serve as modifiers of or pointers to other referenced provisions and that do not have any objectives and functional statements attributed to them, the objectives and functional statements that should be used are those attributed to the provisions they reference.

**A-1.1.3.1.(1) Climatic and Seismic Values.** Climatic values for municipalities not listed in Appendix C may be obtained by writing to the Meteorological Service of Canada, Environment Canada, 4905 Dufferin Street, Toronto, Ontario M3H 5T4.

Seismic values for municipalities not listed in Appendix C may be obtained through the Natural Resources Canada Web site at [www.EarthquakesCanada.ca](http://www.EarthquakesCanada.ca), or by writing to the Geological Survey of Canada at 7 Observatory Crescent, Ottawa, Ontario K1A 0Y3, or at P.O. Box 6000, Sidney, B.C. V8L 4B2.

**A-1.1.3.1.(2) Winter Design Temperatures.** The 2.5% values referred to in Sentence 1.1.3.1.(2) are the least restrictive temperatures that can be used. A designer may choose to use the 1% values given in Appendix C, which are in excess of the Code minimums but are considered acceptable.

**A-1.3.1.2.(1) Applicable Editions.** Where documents are referenced in Appendices A, B and C of this Code, they shall be the editions designated in Table A-1.3.1.2.(1).

**Table A-1.3.1.2.(1)**  
**Documents Referenced in Appendices A, B and C of the National Building Code of Canada 2010**

Issuing Agency	Document Number <sup>(1)</sup>	Title of Document <sup>(2)</sup>	Code Reference
ASCE	SEI/ASCE 8-02	Design of Cold-Formed Stainless Steel Structural Members	A-4.3.4.2.(1)
ASHRAE	2009	ASHRAE Handbook – Fundamentals	A-9.36.2.4.(1) Table A-9.36.2.4.(1)D.
ASHRAE	ANSI/ASHRAE 62-2001	Ventilation for Acceptable Indoor Air Quality (except Addendum n)	A-9.25.5.2.
ASME	B18.6.1-1981	Wood Screws (Inch Series)	A-9.23.3.1.(3)
ASME/CSA	ASME A17.1-2010/CSA B44-10	Safety Code for Elevators and Escalators	A-3.5.2.1.(1)
ASTM	A 390-06	Zinc-Coated (Galvanized) Steel Poultry Fence Fabric (Hexagonal and Straight Line)	Table A-9.10.3.1.B.
ASTM	C 516-08	Vermiculite Loose Fill Thermal Insulation	A-9.25.2.4.(5)
ASTM	C 1193-11a	Use of Joint Sealants	A-Table 5.10.1.1. A-9.27.4.2.(1)
ASTM	C 1299-03	Selection of Liquid-Applied Sealants	A-Table 5.10.1.1. A-9.27.4.2.(1)

This Appendix is included for explanatory purposes only and does not form part of the requirements. The numbers that introduce each Appendix Note correspond to the applicable requirements in this Division.

**Table A-1.3.1.2.(1) (Continued)**

Issuing Agency	Document Number <sup>(1)</sup>	Title of Document <sup>(2)</sup>	Code Reference
ASTM	C 1472-10	Calculating Movement and Other Effects When Establishing Sealant Joint Width	A-Table 5.10.1.1. A-9.27.4.2.(1)
ASTM	D 1037-06a	Evaluating Properties of Wood-Base Fiber and Particle Panel Materials	A-9.23.15.2.(4)
ASTM	D 1143/D 1143M-07e1	Deep Foundations Under Static Axial Compressive Load	A-4.2.7.2.(2)
ASTM	E 336-05	Measurement of Airborne Sound Attenuation between Rooms in Buildings	A-9.11.1.1.(1)
ASTM	E 492-09	Laboratory Measurement of Impact Sound Transmission Through Floor-Ceiling Assemblies Using The Tapping Machine	A-9.11.1.1.(1)
ASTM	E 597-95	Determining a Single Number Rating of Airborne Sound Insulation for Use in Multi-Unit Building Specifications	A-9.11.1.1.(1)
ASTM	E 736-00	Cohesion/Adhesion of Sprayed Fire-Resistive Materials Applied to Structural Members	Table A-9.10.3.1.B.
ASTM	E 1007-11e1	Field Measurement of Tapping Machine Impact Sound Transmission Through Floor-Ceiling Assemblies and Associated Support Structures	A-9.11.1.1.(1)
ASTM	F 476-84	Security of Swinging Door Assemblies	A-9.7.5.2.(2)
CCBFC	NRCC 35951	Guidelines for Application of Part 3 of the National Building Code of Canada to Existing Buildings	A-1.1.1.1.(1) <sup>(3)</sup>
CCBFC	NRCC 38732	National Farm Building Code of Canada 1995	A-1.4.1.2.(1) <sup>(3)</sup> A-Table 4.1.2.1. A-5.1.2.1.(1)
CCBFC	NRCC 40383	User's Guide – NBC 1995, Fire Protection, Occupant Safety and Accessibility (Part 3)	A-1.1.1.1.(1) <sup>(3)</sup>
CCBFC	NRCC 43963	User's Guide – NBC 1995, Application of Part 9 to Existing Buildings	A-1.1.1.1.(1) <sup>(3)</sup>
CCBFC	NRCC 53302	National Plumbing Code of Canada 2010	A-2.2.1.1.(1) <sup>(3)</sup> A-3.2.1.1.(1) <sup>(3)</sup> A-4.1.6.4.(3) A-9.36.5.8.(5) Appendix C
CCBFC	NRCC 53303	National Fire Code of Canada 2010	A-1.1.1.1.(1) <sup>(3)</sup> A-2.2.1.1.(1) <sup>(3)</sup> A-3.1.2.3.(1) A-3.2.1.1.(1) <sup>(3)</sup> A-3.2.4.7.(2) A-3.2.7.8.(3) A-3.3. A-3.3.1.2.(1) A-3.3.1.7.(1) A-3.3.3.1.(1) A-3.3.6.1.(1) B-3.2.6.
CCBFC	NRCC 54435	National Energy Code of Canada for Buildings 2011	A-2.2.1.1.(1) <sup>(3)</sup> A-3.2.1.1.(1) <sup>(3)</sup> A-9.36.1.3. A-9.36.2.4.(1) A-9.36.3.10.(1) A-9.36.4.2.(1) A-9.36.5.2.

**Table A-1.3.1.2.(1) (Continued)**

Issuing Agency	Document Number <sup>(1)</sup>	Title of Document <sup>(2)</sup>	Code Reference
CCBFC	NRCC 53543	User's Guide – NBC 2010, Structural Commentaries (Part 4 of Division B)	A-1.1.1.1.(1) <sup>(3)</sup> A-4.1.1.3.(1) A-4.1.1.3.(2) A-4.1.2.1. A-4.1.2.1.(1) A-4.1.3. A-4.1.3.2.(2) A-4.1.3.2.(4) A-4.1.3.2.(5) A-4.1.3.3.(2) A-4.1.3.4.(1) A-4.1.3.5.(1) A-4.1.3.5.(3) A-4.1.3.6.(1) A-4.1.3.6.(2) A-4.1.3.6.(3) A-4.1.5.8. A-4.1.5.17. A-4.1.6.2. A-4.1.6.2.(4)(b) A-4.1.6.3.(2) A-4.1.6.4.(1) A-4.1.7.1.(1) to (3) A-4.1.7.1.(5)(a) to (c) A-4.1.7.1.(5)(d) A-4.1.7.1.(6)(a) A-4.1.7.1.(6)(c) A-4.1.7.1.(6)(d) and 4.1.7.2.(1)(b) A-4.1.7.2.(1) and (2) A-4.1.7.3.(1) A-4.1.8.2.(1) A-4.1.8.3.(4) A-4.1.8.3.(6) A-4.1.8.3.(7)(b) and (c) A-4.1.8.3.(8) A-4.1.8.4.(3) and Table 4.1.8.4.A. A-Table 4.1.8.5. A-Table 4.1.8.6. A-4.1.8.7.(1) A-4.1.8.9.(4) A-4.1.8.9.(5) A-4.1.8.11.(3) A-4.1.8.12.(1)(a) A-4.1.8.12.(1)(b) A-4.1.8.12.(3) A-4.1.8.12.(4)(a) A-4.1.8.13.(4) A-4.1.8.15.(1) A-4.1.8.15.(3) A-4.1.8.15.(4) A-4.1.8.15.(5) A-4.1.8.15.(6) A-4.1.8.15.(7) A-4.1.8.16.(1) A-4.1.8.16.(3)(a) A-4.1.8.16.(4) A-4.1.8.16.(5)(a) A-4.1.8.16.(7) A-4.1.8.17.(1)

**Table A-1.3.1.2.(1) (Continued)**

Issuing Agency	Document Number <sup>(1)</sup>	Title of Document <sup>(2)</sup>	Code Reference
CCBFC	NRCC 53543	User's Guide – NBC 2010, Structural Commentaries (Part 4 of Division B) (cont.)	A-4.1.8.18. A-4.2.4.1.(3) A-4.2.4.1.(5) A-4.2.5.1.(1) A-4.2.6.1.(1) A-4.2.7.2.(1) A-5.1.4.2. Appendix C
CCBFC	NRCC 38730	Model National Energy Code of Canada for Houses 1997	A-9.36.3.10.(1) A-9.36.4.2.(1)
CGSB	CAN/CGSB-7.2-94	Adjustable Steel Columns	A-9.17.3.4.
CGSB	CAN/CGSB-12.20-M89	Structural Design of Glass for Buildings	A-9.6.1.3.(1)
CGSB	CAN/CGSB-71.26-M88	Adhesive for Field-Gluing Plywood to Lumber Framing for Floor Systems	Table A-9.23.4.2.(2)C.
CGSB	CAN/CGSB-82.6-M86	Doors, Mirrored Glass, Sliding or Folding, Wardrobe	A-9.6.1.2.(2)
CGSB	CAN/CGSB-93.1-M85	Sheet, Aluminum Alloy, Prefinished, Residential	A-9.27.11.1.(3) and (4)
CGSB	CAN/CGSB-93.2-M91	Prefinished Aluminum Siding, Soffits, and Fascia, for Residential Use	A-9.27.11.1.(3) and (4)
CGSB	CAN/CGSB-149.10-M86	Determination of the Airtightness of Building Envelopes by the Fan Depressurization Method	A-9.36.5.10.(11)
CISC	2009	Crane-Supporting Steel Structures: Design Guide	A-4.1.3.2.(2)
CMHC	1993	Testing of Fresh Air Mixing Devices	A-9.32.3.4.
CMHC	1988	Air Permeance of Building Materials	A-5.4.1.2.(1) and (2) Table A-9.25.5.1.(1)
CMHC/HC	2007	Radon: A Guide for Canadian Homeowners	A-5.4.1.1. A-6.2.1.1. A-9.13.4.3.
CSA	CAN/CSA-A23.3-04	Design of Concrete Structures	A-4.1.3.2.(4) A-4.3.3.1.(1)
CSA	A23.4-09	Precast Concrete – Materials and Construction	A-4.3.3.1.(1)
CSA	A82.31-M1980	Gypsum Board Application	Table A-9.10.3.1.A. Table A-9.10.3.1.B.
CSA	A277-08	Procedure for Factory Certification of Buildings	A-1.1.1.1.(2) <sup>(9)</sup>
CSA	CAN/CSA-A370-04	Connectors for Masonry	A-9.21.4.5.(2)
CSA	AAMA/WDMA/CSA 101/I.S.2/A440-11	NAFS – North American Fenestration Standard/Specification for Windows, Doors, and Skylights	A-5.3.1.2. A-9.7.4.2.(1)
CSA	A440S1-09	Canadian Supplement to AAMA/WDMA/CSA 101/I.S.2/A440, NAFS – North American Fenestration Standard/Specification for Windows, Doors, and Skylights	A-5.10.2.2. A-9.7.4.2.(1)
CSA	CAN/CSA-A440.2-09/A440.3-09	Fenestration Energy Performance/User Guide to CSA A440.2-09, Fenestration Energy Performance	A-9.7.4.2.(1) A-Table 9.36.2.7.A.
CSA	B111-1974	Wire Nails, Spikes and Staples	A-Table 9.23.3.5.B.
CSA	B149.1-10	Natural Gas and Propane Installation Code	A-9.10.22.
CSA	B214-12	Installation Code for Hydronic Heating Systems	A-9.36.3.4.(1)
CSA	B365-10	Installation Code for Solid-Fuel-Burning Appliances and Equipment	A-9.33.1.1.(2) A-9.33.5.3.

**Table A-1.3.1.2.(1) (Continued)**

Issuing Agency	Document Number <sup>(1)</sup>	Title of Document <sup>(2)</sup>	Code Reference
CSA	C22.1-12	Canadian Electrical Code, Part I	A-3.1.4.3.(1)(b)(i) A-3.2.4.21.(6)(a) A-3.3.6.2.(4) A-9.10.22. A-9.34.2. A-9.35.2.2.(1)
CSA	CAN/CSA-C439-09	Rating the Performance of Heat/Energy-Recovery Ventilators	A-9.36.3.9.(3)
CSA	F280-12	Determining the Required Capacity of Residential Space Heating and Cooling Appliances	A-9.36.3.2.(1) A-9.36.5.15.(5)
CSA	CAN/CSA-F326-M91	Residential Mechanical Ventilation Systems	A-9.32.3.1.(1) A-9.32.3.5. A-9.32.3.7. A-9.32.3.8. A-9.33.6.13.
CSA	O86-09	Engineering Design in Wood	A-9.15.2.4.(1) A-9.23.4.2.
CSA	O112.9-10	Evaluation of Adhesives for Structural Wood Products (Exterior Exposure)	Table A-9.10.3.1.B.
CSA	O112.10-08	Evaluation of Adhesives for Structural Wood Products (Limited Moisture Exposure)	Table A-9.10.3.1.B.
CSA	O141-05	Softwood Lumber	A-9.3.2.1.(1)
CSA	O437.0-93	OSB and Waferboard	A-9.23.15.4.(2)
CSA	CAN/CSA-S6-06	Canadian Highway Bridge Design Code	A-Table 4.1.5.3. A-Table 4.1.5.9.
CSA	S16-09	Design of Steel Structures	A-4.1.5.11. A-4.3.4.1.(1)
CSA	S304.1-04	Design of Masonry Structures	A-5.1.4.1.(5)(b) and (c)
CSA	CAN/CSA-S406-92	Construction of Preserved Wood Foundations	A-9.15.2.4.(1)
CSA	Z32-09	Electrical Safety and Essential Electrical Systems in Health Care Facilities	A-3.2.7.6.(1)
CSA	Z240 MH Series-09	Manufactured Homes	A-1.1.1.1.(2) <sup>(3)</sup>
CSA	Z240.2.1-09	Structural Requirements for Manufactured Homes	A-1.1.1.1.(2) <sup>(3)</sup>
CSA	Z240.10.1-08	Site Preparation, Foundation, and Anchorage of Manufactured Homes	A-1.1.1.1.(2) <sup>(3)</sup>
CWC	1997	Introduction to Wood Building Technology	A-9.27.3.8.(4)
CWC	2000	Wood Reference Handbook	Table A-9.27.3.8.(4)
CWC	2009	The Span Book	A-9.23.4.2.
CWC	2009	Engineering Guide for Wood Frame Construction	A-9.4.1.1. A-9.23.13.1.
EC	CEPA 1988	Canadian Environmental Protection Act, Section 8, Part 1	A-6.2.1.7.(2)
EPA	625/R-92/016 (1994)	Radon Prevention in the Design and Construction of Schools and Other Large Buildings	A-5.4.1.1.
FPI	Project 43-10C-024 (1988)	Deflection Serviceability Criteria for Residential Floors	A-9.23.4.2.(2)
HC	2004	Fungal Contamination in Public Buildings: Health Effects and Investigation Methods	A-5.5.1.1.
HC	2008	Guide for Radon Measurements in Public Buildings (Schools, Hospitals, Care Facilities, Detention Centres)	A-5.4.1.1. A-6.2.1.1.
HC	2008	Guide for Radon Measurements in Residential Dwellings (Homes)	A-9.13.4.3.

Table A-1.3.1.2.(1) (Continued)

Issuing Agency	Document Number <sup>(1)</sup>	Title of Document <sup>(2)</sup>	Code Reference
HRAI	SAR-G1	HRAI Digest 2005	A-9.36.3.2.(1) A-9.36.3.2.(2) A-9.36.3.4.(1)
HVI	HVI Publication 911-2012	Certified Home Ventilating Products Directory	A-9.36.3.9.(3)
ICC	400-2007	Design and Construction of Log Structures	A-9.36.2.2.(5)
ISO	7010:2003	Graphical symbols – Safety colours and safety signs – Safety signs used in workplaces and public areas	A-3.4.5.1.(2)(c)
ISO	7731:2003(E)	Ergonomics – Danger signals for public and work areas – Auditory danger signals	A-3.2.4.22.(1)(b)
ISO	8201:1987(E)	Acoustics – Audible emergency evacuation signal	A-3.2.4.19.(2)
NFPA	2008 Edition	Fire Protection Handbook, Twentieth Edition	A-3.2.2.2.(1) A-3.6.2.7.(5)
NFPA	2010 Edition	Fire Protection Guide to Hazardous Materials	A-6.2.2.6.(1)
NFPA	13-2013 <sup>(4)</sup>	Installation of Sprinkler Systems	A-3.2.4.10.(3)(f) A-3.2.5.12.(1) A-3.2.5.12.(6) A-3.2.5.13.(1) A-3.2.8.2.(3)
NFPA	13D-2010	Installation of Sprinkler Systems in One- and Two-Family Dwellings and Manufactured Homes	A-3.2.5.12.(6) A-3.2.5.13.(1)
NFPA	13R-2010	Installation of Sprinkler Systems in Residential Occupancies up to and Including Four Stories in Height	A-3.2.5.12.(6) A-3.2.5.13.(1)
NFPA	20-2010	Installation of Stationary Pumps for Fire Protection	A-3.2.4.10.(3)(f)
NFPA	30-2012	Flammable and Combustible Liquids Code	A-6.2.2.6.(1)
NFPA	30A-2012	Motor Fuel Dispensing Facilities and Repair Garages	A-6.2.2.6.(1)
NFPA	32-2011	Drycleaning Plants	A-6.2.2.6.(1)
NFPA	33-2011	Spray Application Using Flammable or Combustible Materials	A-6.2.2.6.(1)
NFPA	34-2011	Dipping, Coating, and Printing Processes Using Flammable or Combustible Liquids	A-6.2.2.6.(1)
NFPA	35-2011	Manufacture of Organic Coatings	A-6.2.2.6.(1)
NFPA	36-2009	Solvent Extraction Plants	A-6.2.2.6.(1)
NFPA	40-2011	Storage and Handling of Cellulose Nitrate Film	A-6.2.2.6.(1)
NFPA	51-2007	Design and Installation of Oxygen-Fuel Gas Systems for Welding, Cutting, and Allied Processes	A-6.2.2.6.(1)
NFPA	51A-2012	Acetylene Cylinder Charging Plants	A-6.2.2.6.(1)
NFPA	55-2010	Compressed Gases and Cryogenic Fluids Code	A-6.2.2.6.(1)
NFPA	61-2008	Prevention of Fires and Dust Explosions in Agricultural and Food Processing Facilities	A-6.2.2.6.(1)
NFPA	68-2007	Explosion Protection by Deflagration Venting	A-3.6.2.7.(5) A-6.2.2.6.(1)
NFPA	69-2008	Explosion Prevention Systems	A-3.6.2.7.(5) A-6.2.2.6.(1)
NFPA	72-2010	National Fire Alarm and Signaling Code	A-3.2.4.22.(2)
NFPA	80-2010	Fire Doors and Other Opening Protectives	A-3.1.8.1.(2) A-3.2.8.2.(3)
NFPA	80A-2012	Protection of Buildings from Exterior Fire Exposures	A-3
NFPA	85-2011	Boiler and Combustion Systems Hazards Code	A-6.2.2.6.(1)
NFPA	86-2011	Ovens and Furnaces	A-6.2.2.6.(1)

**Table A-1.3.1.2.(1) (Continued)**

Issuing Agency	Document Number <sup>(1)</sup>	Title of Document <sup>(2)</sup>	Code Reference
NFPA	88A-2011	Parking Structures	A-6.2.2.6.(1)
NFPA	91-2010	Exhaust Systems for Air Conveying of Vapors, Gases, Mists, and Noncombustible Particulate Solids	A-6.2.2.6.(1)
NFPA	96-2011	Ventilation Control and Fire Protection of Commercial Cooking Operations	A-3.3.1.2.(2) A-6.2.2.6.(1) A-9.10.1.4.(1)
NFPA	101-2012	Life Safety Code	A-3.3.2.1.(2)
NFPA	204-2012	Smoke and Heat Venting	A-6.2.2.6.(1)
NFPA	303-2011	Marinas and Boatyards	A-6.2.2.6.(1)
NFPA	307-2011	Construction and Fire Protection of Marine Terminals, Piers, and Wharves	A-6.2.2.6.(1)
NFPA	409-2011	Aircraft Hangars	A-6.2.2.6.(1)
NFPA	415-2008	Airport Terminal Buildings, Fueling, Ramp Drainage, Loading Walkways	A-6.2.2.6.(1)
NFPA	484-2012	Combustible Metals	A-6.2.2.6.(1)
NFPA	654-2006	Prevention of Fire and Dust Explosions from the Manufacturing, Processing, and Handling of Combustible Particulate Solids	A-6.2.2.6.(1)
NFPA	655-2012	Prevention of Sulfur Fires and Explosions	A-6.2.2.6.(1)
NFPA	664-2012	Prevention of Fires and Explosions in Wood Processing and Woodworking Facilities	A-6.2.2.6.(1)
NFPA	1710-2010	Organization and Deployment of Fire Suppression Operations, Emergency Medical Operations, and Special Operations to the Public by Career Fire Departments	A-3.2.3.1.(8)
NLGA	2010	Standard Grading Rules for Canadian Lumber	A-9.3.2.1.(1) A-Table 9.3.2.1. A-9.3.2.8.(1) A-9.23.10.4.(1)
NLGA	SPS-1-2011	Fingerjoined Structural Lumber	Table A-9.10.3.1.A. A-9.23.10.4.(1)
NLGA	SPS-3-2011	Fingerjoined "Vertical Stud Use Only" Lumber	Table A-9.10.3.1.A. A-9.23.10.4.(1)
NRC-IRC	CBD 222	Airtight Houses and Carbon Monoxide Poisoning	A-9.33.1.1.(2)
NRC-IRC	CBD 230	Applying Building Codes to Existing Buildings	A-1.1.1.1.(1) <sup>(9)</sup>
NRC-IRC	CBD 231	Moisture Problems in Houses	A-9.25.3.1.(1)
NRC-IRC	1988	Performance and Acceptability of Wood Floors – Forintek Studies	A-9.23.4.2.(2)
NRCA	2005	The NRCA Waterproofing Manual	A-5.6.2.1.
NRCA	2011	The NRCA Roofing Manual: Membrane Roof Systems	A-5.6.2.1.
NYCDH	2008	Guidelines on Assessment and Remediation of Fungi in Indoor Environments	A-5.5.1.1.
OMMAH	2006	2006 Building Code Compendium, Volume 2, Supplementary Standard SB-7, Guards for Housing and Small Buildings	A-9.8.8.2.
SMACNA	ANSI/SMACNA 006-2006	HVAC Duct Construction Standards – Metal and Flexible	A-9.36.3.2.(2)
SMACNA	2012	Architectural Sheet Metal Manual, Seventh Edition	A-5.6.2.1.
TC	SOR/2001-286	Transportation of Dangerous Goods Regulations (TDGR)	A-3.3.1.2.(1)
TWC	1993	Details of Air Barrier Systems for Houses	Table A-9.25.5.1.(1)
TWC	1995	High-Rise Residential Construction Guide	A-5.6.2.1.

**Table A-1.3.1.2.(1) (Continued)**

Issuing Agency	Document Number <sup>(1)</sup>	Title of Document <sup>(2)</sup>	Code Reference
ULC	CAN/ULC-S101-07	Fire Endurance Tests of Building Construction and Materials	A-3.1.5.12.(2)(e) Table A-9.10.3.1.B. B-3.2.6.5.(6)(b)
ULC	CAN/ULC-S112-10	Fire Test of Fire Damper Assemblies	Table B-3.2.6.6.C.
ULC	CAN/ULC-S113-07	Wood Core Doors Meeting the Performance Required by CAN/ULC-S104 for Twenty Minute Fire Rated Closure Assemblies	A-9.10.9.3.(2) A-9.10.13.2.(1)
ULC	CAN/ULC-S124-06	Test for the Evaluation of Protective Coverings for Foamed Plastic	A-3.1.5.12.(2)(e)
ULC	ULC-S332-93	Burglary Resisting Glazing Material	A-9.7.5.2.(1)
ULC	CAN/ULC-S524-06	Installation of Fire Alarm Systems	A-3.2.4.19.(8) A-3.2.4.21.(7)
ULC	CAN/ULC-S526-07	Visible Signal Devices for Fire Alarm Systems, Including Accessories	A-3.2.4.20.(2)
ULC	CAN/ULC-S572-10	Photoluminescent and Self-Luminous Signs and Path Marking Systems	A-3.4.5.1.(4)
ULC	CAN/ULC-S701-11	Thermal Insulation, Polystyrene, Boards and Pipe Covering	Table A-9.36.2.4.(1)D.
ULC	CAN/ULC-S702-09	Mineral Fibre Thermal Insulation for Buildings	A-5.10.1.1.(1) Table A-9.36.2.4.(1)D.
ULC	CAN/ULC-S703-09	Cellulose Fibre Insulation for Buildings	Table A-9.36.2.4.(1)D.
ULC	CAN/ULC-S704-11	Thermal Insulation, Polyurethane and Polyisocyanurate, Boards, Faced	Table A-9.36.2.4.(1)D.
ULC	CAN/ULC-S705.1-01	Thermal Insulation – Spray Applied Rigid Polyurethane Foam, Medium Density – Material - Specification	Table A-9.36.2.4.(1)D.
ULC	CAN/ULC-S712.1-10	Thermal Insulation - Light Density, Open Cell Spray Applied Semi-Rigid Polyurethane Foam - Material Specification	Table A-9.36.2.4.(1)D.
ULC	CAN/ULC-S742-11	Air Barrier Assemblies – Specification	A-9.36.2.10.(5)(b)
ULC	CAN/ULC-S770-09	Determination of Long-Term Thermal Resistance of Closed-Cell Thermal Insulating Foams	Table A-9.36.2.4.(1)D.
WCLIB	No. 17 (2004)	Standard Grading Rules	A-Table 9.3.2.1.
WWPA	2011	Western Lumber Grading Rules	A-Table 9.3.2.1.

**Notes to Table A-1.3.1.2.(1):**

- (1) Some documents may have been reaffirmed or reapproved. Check with the applicable issuing agency for up-to-date information.
- (2) Some titles have been abridged to omit superfluous wording.
- (3) Code reference is in Division A.
- (4) Notwithstanding the effective date stated in Sentence 1.3.1.1.(1), the 2013 edition of NFPA 13 is referenced as it better meets the intent of the Code.



**A-3 Application of Part 3.** In applying the requirements of this Part, it is intended that they be applied with discretion to buildings of unusual configuration that do not clearly conform to the specific requirements, or to buildings in which processes are carried out which make compliance with particular requirements in this Part impracticable. The definition of “building” as it applies to this Code is general and encompasses most structures, including those which would not normally be considered as buildings in the layman’s sense. This occurs more often in industrial uses, particularly those involving manufacturing facilities and equipment that require specialized design that may make it impracticable to follow the specific requirements of this Part. Steel mills, aluminum plants, refining, power generation and liquid storage facilities are examples. A water tank or an oil refinery, for example, has no floor area, so it is obvious that requirements for exits from floor areas would not apply. Requirements for structural fire protection in large steel mills and pulp and paper mills, particularly in certain portions, may not be practicable to achieve in terms of the construction normally used and the operations for which the space is to be used. In other portions of the same building, however, it may be quite reasonable to require that the provisions of this Part be applied (e.g., the office portions). Similarly, areas of industrial occupancy which may be occupied only periodically by service staff, such as equipment penthouses, normally would not need to have the same type of exit facility as floor areas occupied on a continuing basis. It is expected that judgment will be exercised in evaluating the application of a requirement in those cases when extenuating circumstances require special consideration, provided the occupants’ safety is not endangered.

The provisions in this Part for fire protection features installed in buildings are intended to provide a minimum acceptable level of public safety. It is intended that all fire protection features of a building, whether required or not, will be designed in conformance with good fire protection engineering practice and will meet the appropriate installation requirements in relevant standards. Good design is necessary to ensure that the level of public safety established by the Code requirements will not be reduced by a voluntary installation.

### Firefighting Assumptions

The requirements of this Part are based on the assumption that firefighting capabilities are available in the event of a fire emergency. These firefighting capabilities may take the form of a paid or volunteer public fire department or in some cases a private fire brigade. If these firefighting capabilities are not available, additional fire safety measures may be required.

Firefighting capability can vary from municipality to municipality. Generally, larger municipalities have greater firefighting capability than smaller ones. Similarly, older, well established municipalities may have better firefighting facilities than newly formed or rapidly growing ones. The level of municipal fire protection considered to be adequate will normally depend on both the size of the municipality (i.e., the number of buildings to be protected) and the size of buildings within that municipality. Since larger buildings tend to be located in larger municipalities, they are generally, but not always, favoured with a higher level of municipal protection.

Although it is reasonable to consider that some level of municipal firefighting capability was assumed in developing the fire safety provisions in Part 3, this was not done on a consistent or defined basis. The requirements in the Code, while developed in the light of commonly prevailing municipal fire protection levels, do not attempt to relate the size of building to the level of municipal protection. The responsibility for controlling the maximum size of building to be permitted in a municipality in relation to local firefighting capability rests with the municipality. If a proposed building is too large, either in terms of floor area or building height, to receive reasonable protection from the municipal fire department, fire protection requirements in addition to those prescribed in this Code, may be necessary to compensate for this deficiency. Automatic sprinkler protection may be one option to be considered.

Alternatively, the municipality may, in light of its firefighting capability, elect to introduce zoning restrictions to ensure that the maximum building size is related to available municipal fire protection facilities. This is, by necessity, a somewhat arbitrary decision and should be made in consultation with the local firefighting service, who should have an appreciation of their capability to fight fires.

The requirements of Subsection 3.2.3. are intended to prevent fire spread from thermal radiation assuming there is adequate firefighting available. It has been found that periods of from 10 to 30 minutes usually elapse between the outbreak of fire in a building that is not protected with an automatic sprinkler system and the attainment of high radiation levels. During this period, the specified spatial separations should



**A-4.1.3.6.(1) Floor Vibration.** Information on floor vibration can be found in the Commentary entitled Deflection and Vibration Criteria for Serviceability and Fatigue Limit States in the User's Guide - NBC 2010, Structural Commentaries (Part 4 of Division B). Information on loads and load combinations for the calculation of vibration can be found in the Commentary entitled Limit States Design in the User's Guide - NBC 2010, Structural Commentaries (Part 4 of Division B).

**A-4.1.3.6.(2) Dynamic Analyses of Floor Vibrations.** Information on a dynamic analysis of floor vibrations from rhythmic activities can be found in the Commentary entitled Deflection and Vibration Criteria for Serviceability and Fatigue Limit States in the User's Guide - NBC 2010, Structural Commentaries (Part 4 of Division B).

**A-4.1.3.6.(3) Lateral Vibration Under Wind Load.** Information on lateral vibrations and accelerations under dynamic wind loads can be found in the Commentary entitled Wind Load and Effects in the User's Guide - NBC 2010, Structural Commentaries (Part 4 of Division B).

**A-4.1.4.1.(6) Counteracting Dead Load Due to Soil.** Examples of structures that traditionally employ the dead load of soil to resist loadings are pylon signs, tower structures, retaining walls, and deadmen, which resist wind uplift and overturning in light structures.

**A-4.1.5.1.(1) Loads Due to Use of Floors and Roofs.** In many areas of buildings, such as equipment areas, service rooms, factories, storage areas, warehouses, museums, and office filing areas, live loads due to their intended use may exceed the minimum specified loads listed in Table 4.1.5.3. In these instances, the probable live load shall be calculated and used as the specified live load for the design of that particular area.

#### **A-Table 4.1.5.3. Considerations for Live Loads.**

##### **Arenas, Grandstands and Stadia**

The designer should give special consideration to the effects of vibration.

##### **Attics - Limited Accessibility**

Attic live loading is not required when the ceiling below the attic consists of removable panels that permit access to the ceiling space without loading the ceiling supporting members. Attic live loading is not required in any area of the attic where the least dimension of the attic space is less than 500 mm.

##### **Corridors, Aisles and Rows of Seats**

The spaces between rows of seats are typically designed for the loads of the occupancy they serve. Rows of seats typically discharge into aisles that are designed for the loads used for the rows of seats. Corridors have a minimum width of 1 100 mm and may serve as collectors for aisles; they are therefore part of the exit system and are required to be designed for a minimum live load of 4.8 kPa.

##### **Floor Areas That Could Be Used As Viewing Areas**

Some interior balconies, mezzanines, corridors, lobbies and aisles that are not intended to be used by an assembly of people as viewing areas are sometimes used as such; consequently, they are subject to loadings much higher than those for the occupancies they serve. Floor areas that may be subject to such higher loads must, therefore, be designed for a loading of 4.8 kPa.

##### **Lecture Halls and Classrooms**

For the purposes of applying the requirements of Table 4.1.5.3., lecture halls with fixed seats are similar to theatres in configuration (the seats may have a writing tablet affixed to one arm). Classrooms are typically furnished with full-sized desks having separate or integrated seats.

##### **Minimum Roof Live Load**

Articles 4.1.5.3. and 4.1.5.10. stipulate a minimum uniform roof live load of 1.0 kPa and a minimum concentrated live load of 1.3 kN. These live loads are "use and occupancy loads" intended to provide for maintenance loadings: they are not reduced as a function of area or as a function of the roof slope due to their variability in distribution and location.

**Vehicle Loads**

A special study should be undertaken to determine the distributed loads to be used for the design of floors and areas used by vehicles exceeding 9 000 kg gross weight and of driveways and sidewalks over areaways and basements. Where appropriate, the designer should refer to CAN/CSA-S6, "Canadian Highway Bridge Design Code."

**A-4.1.5.5. Loads on Exterior Areas.** In Article 4.1.5.5., "accessible" refers to the lack of a physical barrier that prevents or restricts access by vehicles or persons to the site in the context of the specific use.

**A-4.1.5.8. Tributary Area.** Information on tributary area can be found in the Commentary entitled Live Loads in the User's Guide – NBC 2010, Structural Commentaries (Part 4 of Division B).

**A-Table 4.1.5.9. Loads Due to Concentrations.** Special study is required to determine concentrated loads for the design of floors and areas used by vehicles exceeding 9 000 kg gross weight, and of driveways and sidewalks over areaways and basements. Where appropriate the designer should refer to CAN/CSA-S6, "Canadian Highway Bridge Design Code."

**A-4.1.5.11. Crane-Supporting Structures.** Guidance on crane-supporting structures can be found in CSA S16, "Design of Steel Structures."

**A-4.1.5.14. and 4.1.5.15.(1) Design of Guards.** In the design of guards, due consideration should be given to the durability of the members and their connections.

**A-4.1.5.17. Loads on Firewalls.** Information on loads on firewalls can be found in the Commentary entitled Structural Integrity of Firewalls in the User's Guide – NBC 2010, Structural Commentaries (Part 4 of Division B).

**A-4.1.6.2. Coefficients for Snow Loads on Roofs.** Information on coefficients for snow loads on roofs can be found in the Commentary entitled Snow Loads in the User's Guide – NBC 2010, Structural Commentaries (Part 4 of Division B).

**A-4.1.6.2.(4)(b) Unit Weight of Snow.** Information on the unit weight of snow can be found in the Commentary entitled Snow Loads in the User's Guide – NBC 2010, Structural Commentaries (Part 4 of Division B).

**A-4.1.6.3.(2) Full and Partial Loading under Snow Loads.** Information on full and partial snow loading on roofs can be found in the Commentary entitled Snow Loads in the User's Guide – NBC 2010, Structural Commentaries (Part 4 of Division B).

**A-4.1.6.4.(1) Rain Loads.** Information on rain loads can be found in the Commentary entitled Rain Loads in the User's Guide – NBC 2010, Structural Commentaries (Part 4 of Division B).

**A-4.1.6.4.(3) Flow Control Drains.** The National Plumbing Code of Canada 2010 (NPC) contains requirements regarding the use of flow control roof drains. The designer must ensure that the building complies with both the NPC and the NBC.

**A-4.1.7.1.(1) to (3) Pressure Coefficients for Wind Loads.** Information on pressure coefficients can be found in the Commentary entitled Wind Load and Effects in the User's Guide – NBC 2010, Structural Commentaries (Part 4 of Division B).

**A-4.1.7.1.(5)(a) to (c) Simple Procedure for Calculating  $C_e$ .** Information on the simple procedure for calculating  $C_e$  can be found in the Commentary entitled Wind Load and Effects in the User's Guide – NBC 2010, Structural Commentaries (Part 4 of Division B).

**A-4.1.7.1.(5)(d) Dynamic Approach for Wind Loads.** Information on a dynamic approach can be found in the Commentary entitled Wind Load and Effects in the User's Guide – NBC 2010, Structural Commentaries (Part 4 of Division B).

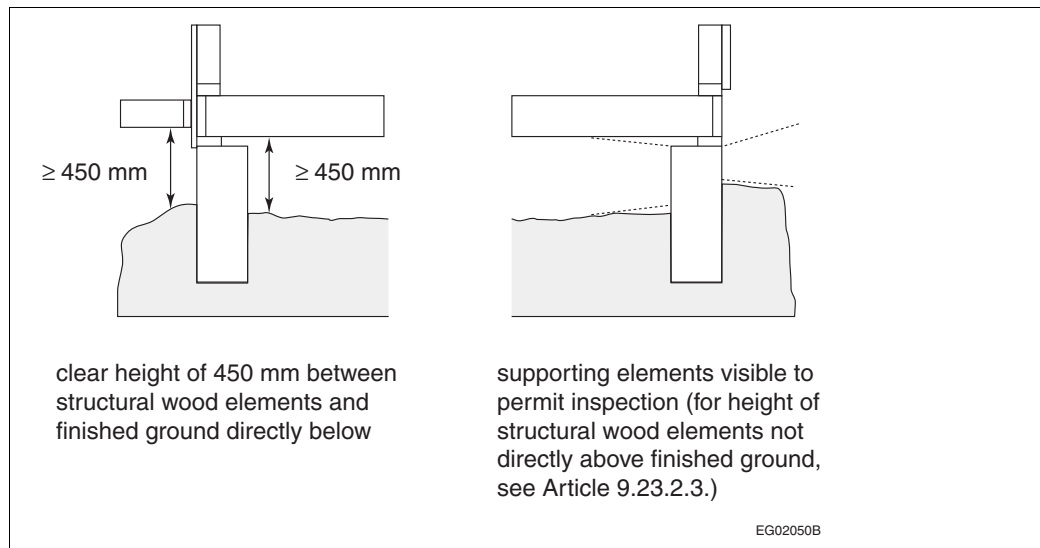

Figure A-9.3.2.9.(1)-B

Clearances under structural wood elements and visibility of supporting elements where required to permit inspection for termite infestation

**A-9.3.2.9.(3) Protection of Structural Wood Elements from Moisture and Decay.** There are many above-ground, structural wood systems where precipitation is readily trapped or drying is slow, creating conditions conducive to decay. Beams extending beyond roof decks, junctions between deck members, and connections between balcony guards and walls are three examples of elements that can accumulate water when exposed to precipitation if they are not detailed to allow drainage.

**A-9.3.2.9.(4) Protection of Retaining Walls and Cribbing from Decay.** Retaining walls supporting soil are considered to be structural elements of the building if a line drawn from the outer edge of the footing to the bottom of the exposed face of the retaining wall is greater than 45° to the horizontal. Retaining walls supporting soil may be structural elements of the building if the line described above has a lower slope.

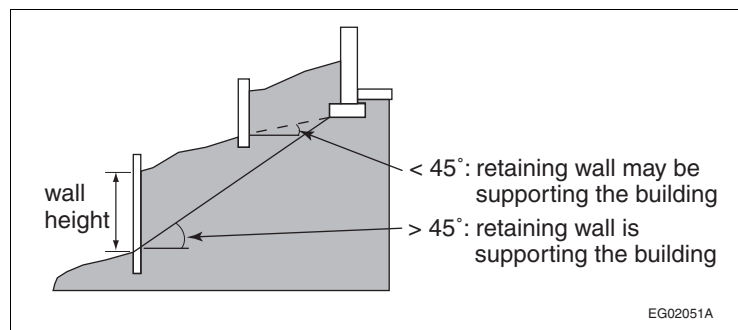

Figure A-9.3.2.9.(4)

Identifying retaining walls that require preservative treatment

Retaining walls that are not critical to the support of building foundations but are greater than 1.2 m in height may pose a danger of sudden collapse to persons adjacent to the wall if the wood is not adequately protected from decay. The height of the retaining wall or cribbing is measured as the vertical difference between the ground levels on each side of the wall.

**A-9.4.1.1. Structural Design.** Article 9.4.1.1. establishes the principle that the structural members of Part 9 buildings must

- comply with the prescriptive requirements provided in Part 9,
- be designed in accordance with accepted good practice, or
- be designed in accordance with Part 4 using the loads and limits on deflection and vibration specified in Part 9 or Part 4.

Usually a combination of approaches is used. For example, even if the snow load calculation on a wood roof truss is based on Subsections 9.4.2., the joints must be designed in accordance with Part 4. Wall framing may comply with the prescriptive requirements in Subsections 9.23.3., 9.23.10., 9.23.11. and 9.23.12., while the floor framing may be engineered.

Design according to Part 4 or accepted good engineering practice, such as that described in CWC 2009, "Engineering Guide for Wood Frame Construction," requires engineering expertise. The CWC Guide contains alternative solutions and provides information on the applicability of the Part 9 prescriptive structural requirements to further assist designers and building officials to identify the appropriate design approach. The need for professional involvement in the structural design of a building, whether to Part 4 or Part 9 requirements or accepted good practice, is defined by provincial and territorial legislation.

**A-9.4.2.2. Application of Simplified Part 9 Snow Loads.** The simplified specified snow loads described in Article 9.4.2.2. may be used where the structure is of the configuration that is typical of traditional wood-frame residential construction and its performance. This places limits on the spacing of joists, rafters and trusses, the spans of these members and supporting members, deflection under load, overall dimensions of the roof and the configuration of the roof. It assumes considerable redundancy in the structure.

Because very large buildings may be constructed under Part 9 by constructing firewalls to break up the building area, it is possible to have Part 9 buildings with very large roofs. The simplified specified snow loads may not be used when the total roof area of the overall structure exceeds 4 550 m<sup>2</sup>. Thus, the simplified specified snow load calculation may be used for typical townhouse construction but would not be appropriate for much larger commercial or industrial buildings, for example.

The simplified specified snow loads are also not designed to take into account roof configurations that seriously exacerbate snow accumulation. This does not pertain to typical projections above a sloped roof, such as dormers, nor does it pertain to buildings with higher and lower roofs. Although two-level roofs generally lead to drift loading, smaller light-frame buildings constructed according to Part 9 have not failed under these loads. Consequently, the simplified calculation may be used in these cases. Rather, this limitation on application of the simplified calculation pertains to roofs with high parapets or significant other projections above the roof, such as elevator penthouses, mechanical rooms or larger equipment that would effectively collect snow and preclude its blowing off the roof.

The reference to Article 9.4.3.1. invokes, for roof assemblies other than common lumber trusses, the same performance criteria for deflection.

The unit weight of snow on roofs,  $\gamma$ , obtained from measurements at a number of weather stations across Canada varied from about 1.0 to 4.5 kN/m<sup>3</sup>. An average value for use in design in lieu of better local data is  $\gamma = 3.0$  kN/m<sup>3</sup>. In some locations the unit weight of snow may be considerably greater than 3.0 kN/m<sup>3</sup>. Such locations include regions where the maximum snow load on the roof is reached only after contributions from many snowstorms, coastal regions, and regions where winter rains are considerable and where a unit weight as high as 4.0 kN/m<sup>3</sup> may be appropriate.

**A-9.4.2.3.(1) Accessible Platforms Subject to Snow and Occupancy Loads.** Many platforms are subject to both occupancy loads and snow loads. These include balconies, decks, verandas, flat roofs over garages and carports. Where such a platform, or a segregated area of such a platform, serves a single dwelling unit, it must be designed for the greater of either the specified snow load or an occupancy load of 1.9 kPa. Where the platform serves more than one single dwelling unit or an occupancy other than a residential occupancy, higher occupancy loads will apply as specified in Table 4.1.5.3.

**A-9.4.2.4.(1) Specified Loads for Attics or Roof Spaces with Limited Accessibility.** Typical residential roofs are framed with roof trusses and the ceiling is insulated.

Residential trusses are placed at 600 mm on centre with web members joining top and bottom chords. Lateral web bracing is installed perpendicular to the span of the trusses. As a result, there is limited room for movement inside the attic or roof space or for storage of material. Access hatches are generally built to the minimum acceptable dimensions, further limiting the size of material that can be moved into the attic or roof space.

With exposed insulation in the attic or roof space, access is not recommended unless protective clothing and breathing apparatus are worn.

Thus the attic or roof space is recognized as uninhabitable and loading can be based on actual dead load. In emergency situations or for the purpose of inspection, it is possible for a person to access the attic or roof space without over-stressing the truss or causing damaging deflections.

**Table A-9.10.3.1.B. (Continued)**

Type of Assembly	As- sembly Number	Description <sup>(1)(2)(3)</sup>	Fire-Resis- tance Rat- ing <sup>(4)(5)(6)(7)</sup>	Typical Sound Transmission Class <sup>(4)(5)(8)(9)</sup> (STC)	Typical Impact Insulation Class <sup>(4)(8)(10)</sup> (IIC)
	F61h	F61 with • steel joists spaced 400 mm o.c. • no absorptive material in cavity • resilient metal channels spaced 600 mm o.c. • 12.7 mm Type X gypsum board	1 h	64	32
	F61i	F61 with • steel joists spaced 600 mm o.c. • no absorptive material in cavity • resilient metal channels spaced 600 mm o.c. • 12.7 mm Type X gypsum board	-	64	28
	F61j	F61 with • absorptive material in cavity • resilient metal channels spaced 400 mm o.c. • 12.7 mm Type X gypsum board	1 h	68	36
	F61k	F61 with • steel joists spaced 400 mm o.c. • absorptive material in cavity • resilient metal channels spaced 600 mm o.c. • 12.7 mm Type X gypsum board	1 h	64	32
	F61l	F61 with • steel joists spaced 600 mm o.c. • no absorptive material in cavity • resilient metal channels spaced 600 mm o.c. • 12.7 mm Type X gypsum board	-	70	34
<b>Roofs</b>					
Wood Roof Trusses	R1	• wood trusses spaced not more than 600 mm o.c. • 1 layer 15.9 mm Type X gypsum board	45 min	-	-
<b>Rating Provided by Membrane Only</b>					
	M1	• supporting members spaced not more than 600 mm o.c. • 1 layer 15.9 mm Type X gypsum board	30 min	-	-
	M2	• supporting members spaced not more than 600 mm o.c. • 2 layers 15.9 mm Type X gypsum board	1 h	-	-

**Notes to Table A-9.10.3.1.B.:**

- (1) For assemblies with a ceiling consisting of a single layer of gypsum board on resilient metal channels to obtain the listed ratings, the resilient metal channel arrangement at the gypsum board butt end joints should be as shown in Figure A-9.10.3.1.-A.
- (2) For assemblies with a ceiling consisting of 2 layers of gypsum board on resilient metal channels to obtain the listed ratings, the fastener and resilient metal channel arrangement at the gypsum board butt end joints should be as shown in Figure A-9.10.3.1.-B.
- (3) The fire-resistance rating and sound transmission class values given are for a minimum thickness of subfloor or deck as shown. Minimum subfloor thickness required is determined by structural member spacing (see Table 9.23.15.5.A.). Thicker subflooring or decking is also acceptable.
- (4) Sound absorptive material includes
  - (i) fibre processed from rock, slag, or glass, and
  - (ii) loose-fill or spray-applied cellulose fibre.

To obtain the listed sound transmission class rating, the nominal insulation thickness is 150 mm for rock, slag, or glass fibres or loose-fill cellulose fibre, and 90 mm for spray-applied cellulose fibre, unless otherwise specified. Absorptive material will affect the sound transmission class by approximately adding or subtracting 1 per 50 mm change of thickness. However, no additional sound transmission class value is achieved by adding a greater thickness of insulation than the depth of the assembly.
- (5) The fire-resistance rating and sound transmission class values are based on the spacing of ceiling supports as noted. (See also Table Note (9).) A narrower spacing will be detrimental to the sound transmission class rating, but not to the fire-resistance rating.
- (6) To obtain the listed rating, the type and spacing of fasteners are as described in and installed in accordance with Subsection 9.29.5. or CSA A82.31-M:

Table A-9.10.3.1.B. (Continued)

- (i) fastener distance to board edges and butt ends should be not less than 38 mm, except for fasteners on the butt ends of the base layer in ceilings with two layers (see Figure A-9.10.3.1.-B); and
  - (ii) fasteners are spaced not more than 300 mm o.c.
- (7) See D-1.2.1.(2) in Appendix D for the significance of fire-resistance ratings.
- (8) The sound transmission class values given in the Table are for the minimum depth of structural member noted in the description and applicable table notes. To obtain sound transmission class values for structural members deeper than that minimum, add 1 to the sound transmission class value in the table for each 170 mm increase in structural member depth.
- (9) The sound transmission class values given in the table are for structural member spacing of 300 mm o.c., unless otherwise noted in the description and applicable table notes. To obtain sound transmission class values for assemblies with structural members spaced more than 500 mm o.c., add 1 to the sound transmission class value in the Table.
- (10) The impact insulation class values given are for floor assemblies tested with no finished flooring.
- (11) Wood floor joists are:
- (i) wood joists with a minimum member size of 38 mm (width) x 235 mm (depth), except as otherwise noted (see Table Note (14)); or
  - (ii) wood I-joists with a minimum flange size of 38 mm x 38 mm, a minimum OSB or plywood web thickness of 9.5 mm, and a minimum joist depth of 241 mm.
- (12) Except where assemblies with wood I-joists are tested according to CAN/ULC-S101, "Fire Endurance Tests of Building Construction and Materials," the fire-resistance rating values apply only to I-joists that have been fabricated with a phenolic-based structural wood adhesive complying with CSA O112.10, "Evaluation of Adhesives for Structural Wood Products (Limited Moisture Exposure)." For I-joists with flanges made of laminated veneer lumber (LVL), the fire-resistance rating values apply only where the adhesive used in the LVL fabrication is a phenolic-based structural wood adhesive complying with CSA O112.9, "Evaluation of Adhesives for Structural Wood Products (Exterior Exposure)."
- (13) The fire-resistance rating value within square brackets is achieved only where absorptive material includes spray-applied cellulose fibre with
- (i) adhesive that is capable of providing a minimum cohesive/adhesive bond strength per unit area of 5 times the weight of the material under the test plate when tested in accordance with ASTM E 736,
  - (ii) a minimum density of 35 kg/m<sup>3</sup>, and
  - (iii) a minimum thickness of 90 mm on the underside of the subfloor or deck, of 90 mm on the sides of the structural members, and for cold-formed steel joists, of 13 mm on the underside of the bottom flange other than at resilient metal channel locations.
- (14) The fire-resistance rating value within square brackets only applies to assemblies with solid wood joists and is achieved only where absorptive material includes:
- (i) fibre processed from rock or slag with a minimum thickness of 90 mm and a minimum surface area mass of 2.8 kg/m<sup>2</sup>; or
  - (ii) spray-applied cellulose fibre with a minimum density of 50 kg/m<sup>3</sup> and a minimum depth of 90 mm on the underside of the subfloor and of 90 mm on the sides of the floor joists.
- (15) The fire-resistance rating, sound transmission class and impact insulation class values given are also applicable to assemblies with 38 mm (width) x 184 mm (depth) solid wood joists.
- (16) The fire-resistance rating value within square brackets is achieved only where absorptive material includes:
- (i) fibre processed from rock or slag with a minimum thickness of 90 mm and a minimum surface area mass of 2.8 kg/m<sup>2</sup>; or
  - (ii) spray-applied cellulose fibre with a minimum density of 50 kg/m<sup>3</sup> and a minimum depth of 90 mm on the underside of the subfloor and of 90 mm on the webs or the sides of the structural members.
- (17) The fire-resistance rating, sound transmission class and impact insulation class values within the square brackets only apply to assemblies with solid wood joists and are achieved only where absorptive material includes dry-blown cellulose fibre with a minimum density of 40 kg/m<sup>3</sup> filling the entire cavity; the cellulose fibre is supported on zinc-coated (galvanized) steel poultry fence fabric conforming to ASTM A 390 which has 25-mm-wide hexagonal mesh openings and 0.81-mm-thick (20-gauge) wire and is attached to wood joists with metal staples having legs that are 50 mm long.
- (18) The fire-resistance rating and sound transmission class values are achieved only where absorptive material includes:
- (i) fibre processed from rock or slag that fills the joist cavity and has a minimum surface area mass of 2.8 kg/m<sup>2</sup>, and for structural members at least 270 mm in depth, the fibre includes three layers each of which has a minimum thickness of 90 mm; or
  - (ii) dry-blown cellulose fibre with a minimum density of 40 kg/m<sup>3</sup> filling the entire cavity; the cellulose fibre is supported on zinc-coated (galvanized) steel poultry fence fabric conforming to ASTM A 390 which has 25-mm-wide hexagonal mesh openings and 0.81-mm-thick (20-gauge) wire and is attached to wood joists or wood I-joists with metal staples having legs that are 50 mm or 30 mm long, respectively.
- (19) The fire-resistance rating value only applies to assemblies with wood I-joists with flanges with a minimum thickness of 38 mm and a minimum width of 63 mm.
- (20) The fire-resistance rating and sound transmission class values are achieved only where absorptive material includes:
- (i) fibre processed from rock or slag that fills the joist cavity and has a minimum surface area mass of 2.8 kg/m<sup>2</sup>, and for structural members at least 270 mm in depth, the fibre includes three layers each of which has a minimum thickness of 90 mm; or
  - (ii) dry-blown cellulose fibre with a minimum density of 40 kg/m<sup>3</sup> filling the entire cavity; the cellulose fibre is supported on zinc-coated (galvanized) steel poultry fence fabric conforming to ASTM A 390 which has 25-mm-wide hexagonal mesh openings and 0.81-mm-thick (20-gauge) wire and is attached to wood joists with metal staples having legs that are 50 mm long.
- (21) The fire-resistance rating values given only apply to assemblies with solid wood joists spaced not more than 400 mm o.c. No information is available for assemblies constructed with wood I-joists.
- (22) Wood floor trusses are:



**Table A-9.10.3.1.B. (Continued)**

- (i) metal-plate-connected wood trusses with wood framing members not less than 38 mm x 64 mm, metal connector plates not less than 1 mm (nominal) thick with teeth not less than 8 mm long, and a minimum truss depth of 305 mm;
  - (ii) metal-web wood trusses with wood chords not less than 38 mm x 64 mm, V-shaped webs made from galvanized steel of 1 mm (nominal) thickness with plate areas having teeth not less than 8 mm long, and a minimum truss depth of 286 mm; or
  - (iii) finger-joined wood trusses with glued finger-joined connections, chord members not less than 38 mm x 64 mm, web members not less than 38 mm x 38 mm and a minimum truss depth of 330 mm, all of which is glued together with an R-14 phenol-resorcinol resin conforming to CSA O112.10.
- (23) The fire-resistance rating value within square brackets is achieved only where absorptive material includes fibre processed from rock or slag with a minimum thickness of 90 mm and a minimum surface area mass of 2.8 kg/m<sup>2</sup>.
- (24) The fire-resistance rating and sound transmission class values within square brackets are achieved only where absorptive material includes dry-blown cellulose fibre with a minimum density of 40 kg/m<sup>3</sup> filling the entire cavity; the cellulose fibre is supported on zinc-coated (galvanized) steel poultry fence fabric conforming to ASTM A 390 which has 25-mm-wide hexagonal mesh openings and 0.81-mm-thick (20-gauge) wire and is attached to wood trusses with metal staples having legs that are 38 mm long.
- (25) Cold-formed steel floor joists (C-shaped joists) are members with a minimum size of 41 mm (width) x 203 mm (depth) x 1.22 mm (material thickness).
- (26) The fire-resistance rating value within square brackets is achieved only where absorptive material includes spray-applied cellulose fibre with a minimum density of 50 kg/m<sup>3</sup> and a minimum thickness of 90 mm on the underside of the subfloor, of 90 mm on the sides of the cold-formed steel floor joists, and of 13 mm on the underside of the bottom flange other than at resilient metal channel locations.

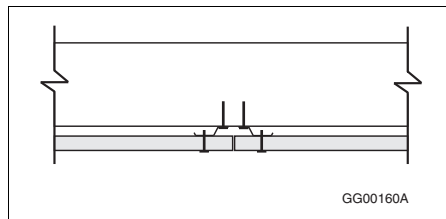

**Figure A-9.10.3.1-A**  
**Single layer butt joint details**

**Notes to Figure A-9.10.3.1-A:**

- (1) Figure is for illustrative purposes only and is not to scale.
- (2) The structural member can be any one of the types described in the Table.
- (3) Adjacent gypsum board butt ends are attached to separate resilient channels using regular Type S screws, located a minimum of 38 mm from the butt end.

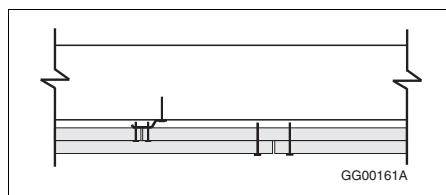

**Figure A-9.10.3.1-B**  
**Double layer butt joint details**

**Notes to Figure A-9.10.3.1-B:**

- (1) Figure is for illustrative purposes only and is not to scale.
- (2) The structural member can be any one of the types described in the Table.
- (3) Base layer butt ends can be attached to a single resilient channel using regular Type S screws.
- (4) Type G screws measuring a minimum of 32 mm in length and located a minimum of 38 mm from the butt end are used to fasten the butt ends of the face layer to the base layer.

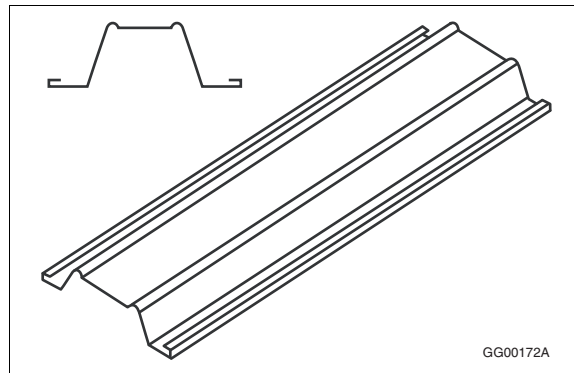

**Figure A-9.10.3.1.-C**  
**Example of steel furring channel**

**Note to Figure A-9.10.3.1.-C:**

(1) Figure is for illustrative purposes only and is not to scale.

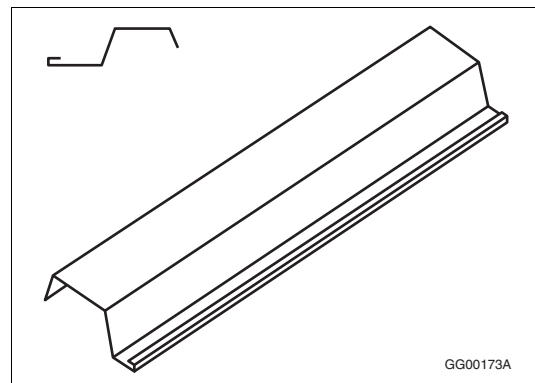

**Figure A-9.10.3.1.-D**  
**Example of resilient metal channel**

**Note to Figure A-9.10.3.1.-D:**

(1) Figure is for illustrative purposes only and is not to scale.

**A-9.10.4.1.(4) Mezzanines Not Considered as Storeys.** Mezzanines increase the occupant load and the fire load of the storey of which they are part. To take the added occupant load into account for the purpose of evaluating other requirements that are dependent on this criteria, their floor area is added to the floor area of the storey.

**A-9.10.8.3.(2) Light-frame Construction.** Light-frame walls, columns, arches and beams do not include heavy timber elements or masonry or concrete construction.

**A-9.10.9.2.(3) Continuity of Smoke-Tight Barrier.** The continuity of a smoke-tight barrier where it abuts another smoke-tight barrier, a floor, a ceiling or a wall assembly, is maintained by filling all openings at the juncture of the assemblies with a material that will ensure the integrity of the smoke-tight barrier at that location.

**A-9.10.9.3.(2) Openings in Smoke-Tight Barriers to be Protected with Closures.** Doors described in Sentence 9.10.9.3.(2) are deemed to provide a minimum 20 min fire-protection rating, which is considered an acceptable level of protection against the spread of fire in a house with a secondary suite. They are not required to be marked to identify conformance to CAN/ULC-S113, "Wood Core Doors Meeting the Performance Required by CAN/ULC-S104 for Twenty Minute Fire Rated Closure Assemblies," as is the case for solid-core doors installed in fire separations.

**A-9.10.9.6.(1) Penetration of Fire-Rated Assemblies by Service Equipment.** This Sentence, together with Article 3.1.9.1., is intended to ensure that the integrity of fire-rated assemblies is maintained where they are penetrated by various types of service equipment.

where

A, B = constants, the values of which are determined from Tables A-9.23.4.2.(2)A. or B.,

G = constant, the value of which is determined from Table A-9.23.4.2.(2)C.,

$S_i$  = span which results in a 2 mm deflection of the joist in question under a 1 kN concentrated midpoint load,

$S_{184}$  = span which results in a 2 mm deflection of a 38 x 184 mm joist of same species and grade as the joist in question under a 1 kN concentrated midpoint load.

For a given joist species and grade, the value of K shall not be greater than  $K_3$ , the value which results in a vibration-controlled span of exactly 3 m. This means that for vibration-controlled spans 3 m or less, K always equals  $K_3$ , and for vibration-controlled spans greater than 3 m, K is as calculated.

Note that, for a sawn lumber joist, the ratio  $S_i/S_{184}$  is equivalent to its depth (mm) divided by 184.

Due to rounding differences, the method, as presented here, might produce results slightly different from those produced by the computer program used to generate the span tables.

**Table A-9.23.4.2.(2)A.**  
**Constants A and B for Calculating Vibration-Controlled Floor Joist Spans – General Cases**

Subfloor Thickness, mm	With Strapping <sup>(1)</sup>			With Bridging			With Strapping and Bridging		
	Joist Spacing, mm			Joist Spacing, mm			Joist Spacing, mm		
	300	400	600	300	400	600	300	400	600
Constant A									
15.5	0.30	0.25	0.20	0.37	0.31	0.25	0.42	0.35	0.28
19.0	0.36	0.30	0.24	0.45	0.37	0.30	0.50	0.42	0.33
Constant B									
	0.33			0.38			0.41		

**Notes to Table A-9.23.4.2.(2)A.:**

(1) Gypsum board attached directly to joists can be considered equivalent to strapping.

**Table A-9.23.4.2.(2)B.**  
**Constants A and B for Calculating Vibration-Controlled Floor Joist Spans – Special Cases**

Subfloor Thickness, mm	Joists with Ceiling Attached to Wood Furring <sup>(1)</sup>						Joists with Concrete Topping <sup>(2)</sup>		
	Without Bridging			With Bridging			With or Without Bridging		
	Joist Spacing, mm			Joist Spacing, mm			Joist Spacing, mm		
	300	400	600	300	400	600	300	400	600
Constant A									
15.5	0.39	0.33	0.24	0.49	0.44	0.38	0.58	0.51	0.41
19.0	0.42	0.36	0.27	0.51	0.46	0.40	0.62	0.56	0.47
Constant B									
	0.34			0.37			0.35		

**Notes to Table A-9.23.4.2.(2)B.:**

(1) Wood furring means 19 x 89 mm boards not more than 600 mm o.c., or 19 x 64 mm boards not more than 300 mm o.c. For all other cases, see Table A-9.23.4.2.(2)A.

(2) 30 mm to 51 mm normal weight concrete (not less than 20 MPa) placed directly on the subflooring.

Table A-9.23.4.2.(2)C.  
Constant G for Calculating Vibration-Controlled Floor Joist Spans

Floor Description	Constant G
Floors with nailed <sup>(1)</sup> subfloor	0.00
Floor with nailed and field-glued <sup>(2)</sup> subfloor, vibration-controlled span greater than 3 m	0.10
Floor with nailed and field-glued <sup>(2)</sup> subfloor, vibration-controlled span 3 m or less	0.15

**Notes to Table A-9.23.4.2.(2)C.:**

- (1) Common wire nails, spiral nails or wood screws can be considered equivalent for this purpose.  
 (2) Subfloor field-glued to floor joists with elastomeric adhesive complying with CAN/CGSB-71.26-M, "Adhesive for Field-Gluing Plywood to Lumber Framing for Floor Systems."

Additional background information on this method can be found in the following publications:

- Onysko, D.M. Deflection Serviceability Criteria for Residential Floors. Project 43-10C-024. Forintek Canada Corp., Ottawa, Canada 1988.
- Onysko, D.M. Performance and Acceptability of Wood Floors – Forintek Studies. Proceedings of Symposium/Workshop on Serviceability of Buildings, Ottawa, May 16-18, National Research Council of Canada, Ottawa, 1988.

**A-9.23.4.3.(1) Maximum Spans for Steel Beams Supporting Floors in Dwellings.** A beam may be considered to be laterally supported if wood joists bear on its top flange at intervals of 600 mm or less over its entire length, if all the load being applied to this beam is transmitted through the joists and if 19 mm by 38 mm wood strips in contact with the top flange are nailed on both sides of the beam to the bottom of the joists supported. Other additional methods of positive lateral support are acceptable.

For supported joist lengths intermediate between those in the table, straight line interpolation may be used in determining the maximum beam span.

**A-Table 9.23.4.3. Spans for Steel Beams.** The spans provided in Table 9.23.4.3. reflect a balance of engineering and acceptable proven performance. The spans have been calculated based on the following assumptions:

- simply supported beam spans
- laterally supported top flange
- yield strength 350 MPa
- deflection limit  $L/360$
- live load: first floor = 1.9 kPa; second floor = 1.4 kPa
- dead load = 1.5 kPa (0.5 kPa floor + 1.0 kPa partition)

The calculation used to establish the specified maximum beam spans also applies a revised live load reduction factor to account for the lower probability of a full live load being applied over the supported area in Part 9 buildings.

**A-9.23.4.4. Concrete Topping.** Vibration-controlled spans given in Table A-2 for concrete topping are based on a partial composite action between the concrete, subflooring and joists. Normal weight concrete having a compressive strength of not less than 20 MPa, placed directly on the subflooring, provides extra stiffness and results in increased capacity. The use of a bond breaker between the topping and the subflooring, or the use of lightweight concrete topping limits the composite effects.

Where either a bond breaker or lightweight topping is used, Table A-1 may be used but the additional dead load imposed by the concrete must be considered. The addition of 51 mm of concrete topping can impose an added load of 0.8 to 1.2 kPa, depending on the density of the concrete.

# Appendix D

## Fire-Performance Ratings

### Section D-1 General

The content of this Appendix was prepared on the recommendations of the Standing Committee on Fire Safety and Occupancy, which was established by the Canadian Commission on Building and Fire Codes (CCBFC) for this purpose.

#### D-1.1. Introduction

##### D-1.1.1. Scope

- 1)** This fire-performance information is presented in a form closely linked to the performance requirements and the minimum materials specifications of the National Building Code of Canada 2010.
- 2)** The ratings have been assigned only after careful consideration of all available literature on assemblies of common building materials, where they are adequately identified by description. The assigned values based on this information will, in most instances, be conservative when compared to the ratings determined on the basis of actual tests on individual assemblies.
- 3)** The fire-performance information set out in this Appendix applies to materials and assemblies of materials which comply in all essential details with the minimum structural design standards described in Part 4 of the National Building Code of Canada. Additional requirements, where appropriate, are described in other Sections of this Appendix.
- 4)** Section D-2 of this Appendix assigns fire-resistance ratings for walls, floors, roofs, columns and beams related to CAN/ULC-S101, "Fire Endurance Tests of Building Construction and Materials," and describes methods for determining these ratings.
- 5)** Section D-3 assigns flame-spread ratings and smoke developed classifications for surface materials related to CAN/ULC-S102, "Test for Surface Burning Characteristics of Building Materials and Assemblies," and CAN/ULC-S102.2, "Test for Surface Burning Characteristics of Flooring, Floor Coverings, and Miscellaneous Materials and Assemblies."
- 6)** Section D-4 describes noncombustibility in building materials when tested in accordance with CAN/ULC-S114, "Test for Determination of Non-Combustibility in Building Materials."
- 7)** Section D-5 contains requirements for the installation of fire doors and fire dampers in fire-rated stud wall assemblies and the installation of fire stop flaps in fire-rated membrane ceilings.
- 8)** Section D-6 contains background information regarding fire test reports, obsolete materials and assemblies, assessment of archaic assemblies and the development of the component additive method.

##### D-1.1.2. Referenced Documents

- 1)** Where documents are referenced in this Appendix, they shall be the editions designated in Table D-1.1.2.

---

This Appendix is included for explanatory purposes only and does not form part of the requirements. The bold face reference numbers that introduce each item do not relate to specific requirements in this Division.

**Table D-1.1.2.**  
**Documents Referenced in Appendix D Fire-Performance Ratings**

Issuing Agency	Document Number <sup>(1)</sup>	Title of Document <sup>(2)</sup>	Code Reference
ANSI	A208.1-2009	Particleboard	Table D-3.1.1.A.
ASTM	C 330/C 330M-09	Lightweight Aggregates for Structural Concrete	D-1.4.3.(2)
ASTM	C 1396/C 1396M-11	Gypsum Board	D-1.5.1. Table D-3.1.1.A.
CCBFC	NRCC 30629	Supplement to the National Building Code of Canada 1990	D-6.2. D-6.3. D-6.4.
CGSB	4-GP-36M-1978	Carpet Underlay, Fiber Type	Table D-3.1.1.B.
CGSB	CAN/CGSB-4.129-97	Carpets for Commercial Use	Table D-3.1.1.B.
CGSB	CAN/CGSB-11.3-M87	Hardboard	Table D-3.1.1.A.
CGSB	CAN/CGSB-92.2-M90	Trowel or Spray Applied Acoustical Material	D-2.3.4.(5)
CSA	A23.1-09/A23.2-09	Concrete Materials and Methods of Concrete Construction/Test Methods and Standard Practices for Concrete	D-1.4.3.(1)
CSA	CAN/CSA-A23.3-04	Design of Concrete Structures	D-2.1.5.(2) D-2.6.6.(1) Table D-2.6.6.B. D-2.8.2.(1) Table D-2.8.2.
CSA	A82.5-M1978	Structural Clay Non-Load-Bearing Tile	Table D-2.6.1.A.
CSA	A82.22-M1977	Gypsum Plasters	Table D-3.1.1.A.
CSA	CAN/CSA-A82.27-M91	Gypsum Board	D-1.5.1. Table D-3.1.1.A.
CSA	A82.30-M1980	Interior Furring, Lathing and Gypsum Plastering	D-1.7.2.(1) D-2.3.9.(1) Table D-2.5.1.
CSA	A82.31-M1980	Gypsum Board Application	D-2.3.9.(1) D-2.3.9.(6)
CSA	CAN/CSA-A165.1-04	Concrete Block Masonry Units	Table D-2.1.1.
CSA	O86-09	Engineering Design in Wood	D-2.11.2.(1) D-2.11.2.(2)
CSA	O121-08	Douglas Fir Plywood	Table D-3.1.1.A.
CSA	O141-05	Softwood Lumber	D-2.3.6.(2) Table D-2.4.1.
CSA	O151-09	Canadian Softwood Plywood	Table D-3.1.1.A.
CSA	O153-M1980	Poplar Plywood	Table D-3.1.1.A.
CSA	O325-07	Construction Sheathing	Table D-3.1.1.A.
CSA	O437.0-93	OSB and Waferboard	Table D-3.1.1.A.
CSA	S16-09	Design of Steel Structures	D-2.6.6.(1) D-2.6.6.(3) Table D-2.6.6.B.
NFPA	80-2010	Fire Doors and Other Opening Protectives	D-5.2.1.(1) D-5.2.1.(2)
ULC	CAN/ULC-S101-07	Fire Endurance Tests of Building Construction and Materials	D-1.1.1.(4) D-1.12.1. D-2.3.2.
ULC	CAN/ULC-S102-10	Test for Surface Burning Characteristics of Building Materials and Assemblies	D-1.1.1.(5)

**Table D-1.1.2. (Continued)**

Issuing Agency	Document Number <sup>(1)</sup>	Title of Document <sup>(2)</sup>	Code Reference
ULC	CAN/ULC-S102.2-10	Test for Surface Burning Characteristics of Flooring, Floor Coverings, and Miscellaneous Materials and Assemblies	D-1.1.1.(5) Table D-3.1.1.B.
ULC	CAN/ULC-S114-05	Test for Determination of Non-Combustibility in Building Materials	D-1.1.1.(6) D-4.1.1.(1) D-4.2.1.
ULC	ULC-S505-1974	Fusible Links for Fire Protection Service	D-5.3.2.
ULC	CAN/ULC-S702-09	Mineral Fibre Thermal Insulation for Buildings	Table D-2.3.4.A. Table D-2.3.4.D. D-2.3.5.(2) D-2.3.5.(4) Table D-2.6.1.E. D-6.4.
ULC	CAN/ULC-S703-09	Cellulose Fibre Insulation for Buildings	D-2.3.4.(5)
ULC	CAN/ULC-S706-09	Wood Fibre Insulating Boards for Buildings	Table D-3.1.1.A.

**Notes to Table D-1.1.2.:**

- (1) Some documents may have been reaffirmed or reapproved. Check with the applicable issuing agency for up-to-date information.
- (2) Some titles have been abridged to omit superfluous wording.

**D-1.1.3. Applicability of Ratings**

The ratings shown in this document apply if more specific test values are not available. The construction of an assembly that is the subject of an individual test report must be followed in all essential details if the fire-resistance rating reported is to be applied for use with this Code.

**D-1.1.4. Higher Ratings**

The authority having jurisdiction may allow higher fire-resistance ratings than those derived from this Appendix, where supporting evidence justifies a higher rating. Additional information is provided in summaries of published test information and the reports of fire tests carried out by the Institute for Research in Construction, National Research Council of Canada, included in Section D-6, Background Information.

**D-1.1.5. Additional Information on Fire Rated Assemblies**

Assemblies containing materials for which there is no nationally recognized standard are not included in this Appendix. Many such assemblies have been rated by Underwriters Laboratories (UL), Underwriters' Laboratories of Canada (ULC), or Intertek Testing Services NA Ltd. (ITS).

**D-1.2. Interpretation of Test Results**

**D-1.2.1. Limitations**

- 1)** The fire-performance ratings set out in this Appendix are based on those that would be obtained from the standard methods of test described in the Code. The test methods are essentially a means of comparing the performance of one building component or assembly with another in relation to its performance in fire.
- 2)** Since it is not practicable to measure the fire resistance of constructions in situ, they must be evaluated under some agreed test conditions. A specified fire-resistance rating is not necessarily the actual time that the assembly would endure in situ in a building fire, but is that which the particular construction must meet under the specified methods of test.
- 3)** Considerations arising from departures in use from the conditions established in the standard test methods may, in some circumstances, have to be taken into account by the designer and the authority having jurisdiction. Some of these conditions are covered at present by the provisions of the National Building Code.

4) For walls and partitions, the stud spacings previously specified as 16 or 24 inch have been converted to 400 and 600 mm, respectively, for consistency with other metric values; however, the use of equivalent imperial dimensions for stud spacing is permitted.

### **D-1.3. Concrete**

#### **D-1.3.1. Aggregates in Concrete**

Low density aggregate concretes generally exhibit better fire performance than natural stone aggregate concretes. A series of tests on concrete masonry walls, combined with mathematical analysis of the test results, has allowed further distinctions between certain low density aggregates to be made.

### **D-1.4. Types of Concrete**

#### **D-1.4.1. Description**

1) For purposes of this Appendix, concretes are described as Types S, N, L, L<sub>1</sub>, L<sub>2</sub>, L40S, L<sub>1</sub>20S or L<sub>2</sub>20S as described in Sentences (2) to (8).

2) Type S concrete is the type in which the coarse aggregate is granite, quartzite, siliceous gravel or other dense materials containing at least 30% quartz, chert or flint.

3) Type N concrete is the type in which the coarse aggregate is cinders, broken brick, blast furnace slag, limestone, calcareous gravel, trap rock, sandstone or similar dense material containing not more than 30% of quartz, chert or flint.

4) Type L concrete is the type in which all the aggregate is expanded slag, expanded clay, expanded shale or pumice.

5) Type L<sub>1</sub> concrete is the type in which all the aggregate is expanded shale.

6) Type L<sub>2</sub> concrete is the type in which all the aggregate is expanded slag, expanded clay or pumice.

7) Type L40S concrete is the type in which the fine portion of the aggregate is sand and low density aggregate in which the sand does not exceed 40% of the total volume of all aggregates in the concrete.

8) Type L<sub>1</sub>20S and Type L<sub>2</sub>20S concretes are the types in which the fine portion of the aggregate is sand and low density aggregate in which the sand does not exceed 20% of the total volume of all aggregates in the concrete.

#### **D-1.4.2. Determination of Ratings**

Where concretes are described as being of Type S, N, L, L<sub>1</sub> or L<sub>2</sub>, the rating applies to the concrete containing the aggregate in the group that provides the least fire resistance. If the nature of an aggregate cannot be determined accurately enough to place it in one of the groups, the aggregate shall be considered as being in the group that requires a greater thickness of concrete for the required fire resistance.

#### **D-1.4.3. Description of Aggregates**

1) The descriptions of the aggregates in Type S and Type N concretes apply to the coarse aggregates only. Coarse aggregate for this purpose means that retained on a 5 mm sieve using the method of grading aggregates described in CSA A23.1/A23.2, "Concrete Materials and Methods of Concrete Construction/Test Methods and Standard Practices for Concrete."

2) Increasing the proportion of sand as fine aggregate in low density concretes requires increased thicknesses of material to produce equivalent fire-resistance ratings. Low density aggregates for Type L and Types L-S concretes used in loadbearing components shall conform to ASTM C 330M, "Lightweight Aggregates for Structural Concrete."

3) Non-loadbearing low density components of vermiculite and perlite concrete, in the absence of other test evidence, shall be rated on the basis of the values shown for Type L concrete.



### Conversion Factors

To Convert	To	Multiply by
°C	°F	1.8 and add 32
kg	lb.	2.205
kPa	lbf/in. <sup>2</sup> (psi)	0.1450
kPa	lbf/ft. <sup>2</sup>	20.88
kW	Btu/h	3412
L	gal. (imp.)	0.2200
L/s	gal./min (gpm)	13.20
lx	ft.-candle	0.09290
m	ft.	3.281
m <sup>2</sup>	ft. <sup>2</sup>	10.76
m <sup>3</sup>	ft. <sup>3</sup>	35.31
mm	in.	0.03937
m <sup>3</sup> /h	ft. <sup>3</sup> /min (cfm)	0.5886
m/s	ft./min	196.8
MJ	Btu	947.8
N	lbf	0.2248
ng/(Pa·s·m <sup>2</sup> )	Btu/h	3.412

