

Supplementary information for *Laboratory evaluation of two particulate-matter thermal carbon analyzers*

Joel C. Corbin, Daniel Clavel, Greg J. Smallwood

Metrology Research Centre, National Research Council Canada, Ottawa, Ontario, Canada

Corresponding author: tel 613-993-2176, Joel.Corbin@nrc-cnrc.gc.ca

S2. TOA Thermograms

S1.1. TCA08 calibration with bulk, aerosol, and humidified sucrose

We repeated our sucrose calibration using bulk sucrose powder (as purchased), aqueous sucrose dispensed by an analytical syringe, sucrose nanoparticles (from our standard nebulize-and-dry procedure) and sucrose nanoparticles exposed to a humidification-and-drying cycle after collection on a quartz filter.

The humidified-and-dried sucrose sample was prepared by loading two quartz filters with sucrose, then exposing each filter to a high flow of humidified or dry (control) air, respectively. Both filters were then exposed to a flow of dry air, then filter punches were analyzed with the TCA08 and with TOA. The humidifier was set to 90% humidity to allow sucrose to deliquesce from crystals into solution droplets. The goal of this humidification was to allow the sucrose nanoparticles to spread onto the filter, changing their surface area without changing their mass.

The resulting four different sucrose thermograms shown in Figure S2 had only minor differences to one another. The bulk sucrose powder and solution resulted in similar signals, after normalization to the total mass. The humidified sucrose nanoparticles appear to lose a right shoulder which was present in the dry-nanoparticle thermogram, possibly due to an increase in surface area after by humidifying and drying. The bulk sucrose samples did not show any difference in

28 response factor to the sucrose nanoparticles, so particle size cannot explain the
29 response factor of 0.1 from Figure 4 of the manuscript.

30 *S1.2. Additional figures*

31

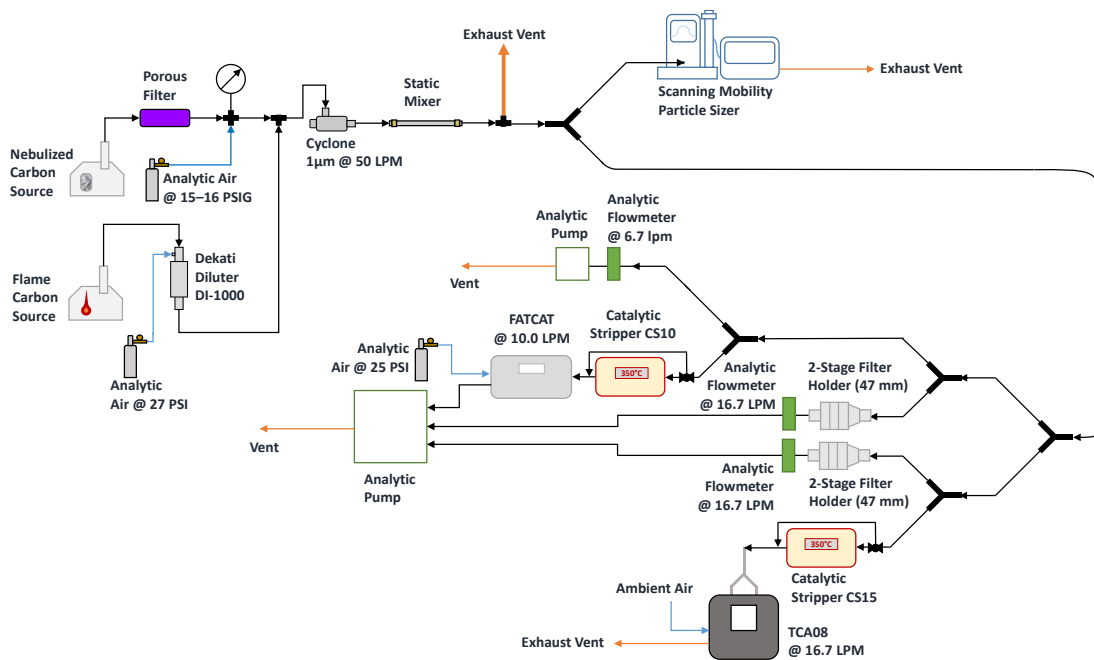

32

33 Figure S1. Experimental setup. The setup allowed the two RTPOs and filter
34 samplers to sample simultaneously from flame sources or the nebulizer. The SMPS
35 was primarily used to monitor the system status during experiments. In some
36 experiments, the SMPS was replaced by a laser-induced incandescence (Artium
37 Technologies LII-300) instrument to obtain rBC mass concentrations.

38

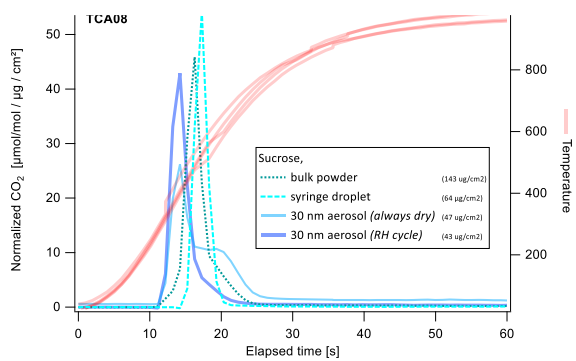

39

40 Figure S2. TCA08 sucrose thermograms for bulk samples, normalized to the total
 41 sucrose mass on the filter punch measured by TOA. The factor-of-ten difference in
 42 the response factors shown in Figure 4 of the manuscript is not visible here,
 43 although some minor differences are apparent.

44

45

46 **S2. TOA Thermograms**

47 This section presents TOA thermograms of the materials discussed in the main
48 text. Not all materials are included because not all could be generated in high
49 enough concentrations to obtain TOA thermograms from the aerosol phase.
50

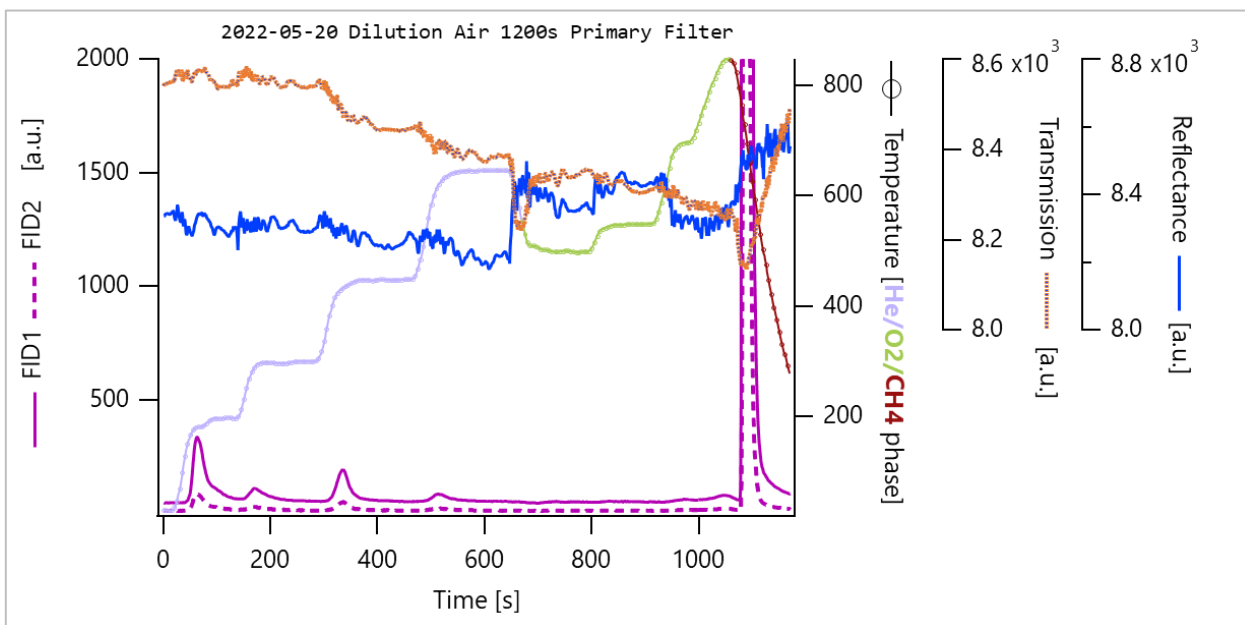

51
52 **Figure S3. Thermogram of Dilution Air - Primary Filter showing solid phase matter**

53

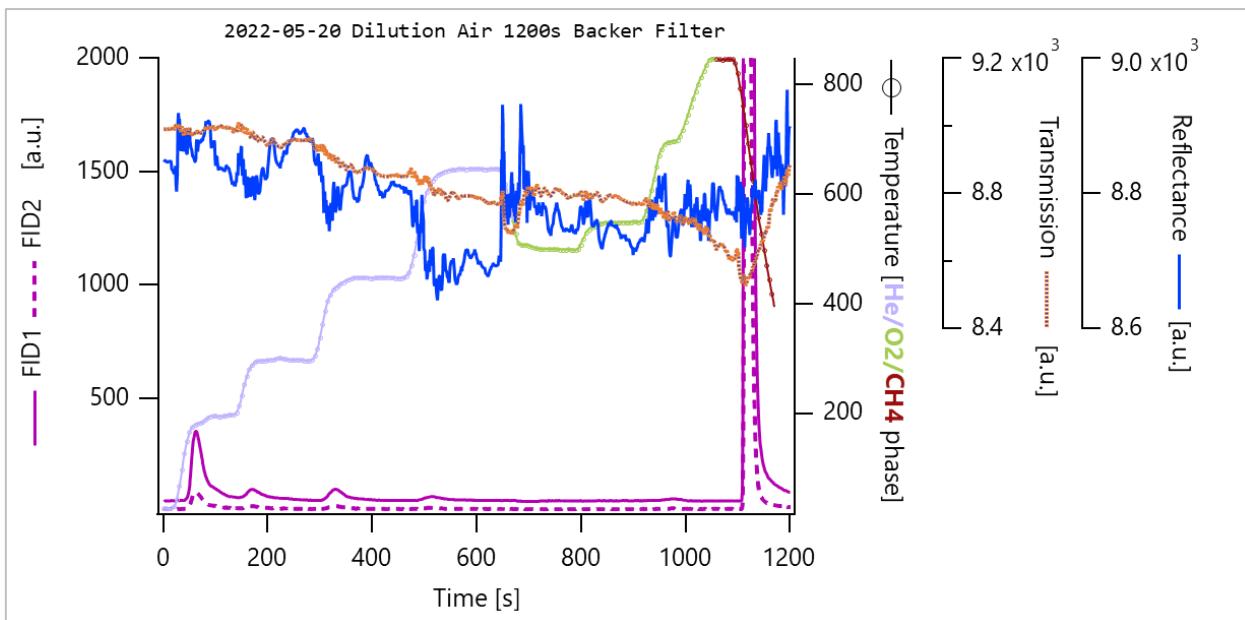

54
55 **Figure S4. Thermogram of Dilution Air - Backer Filter showing gas phase matter**

56

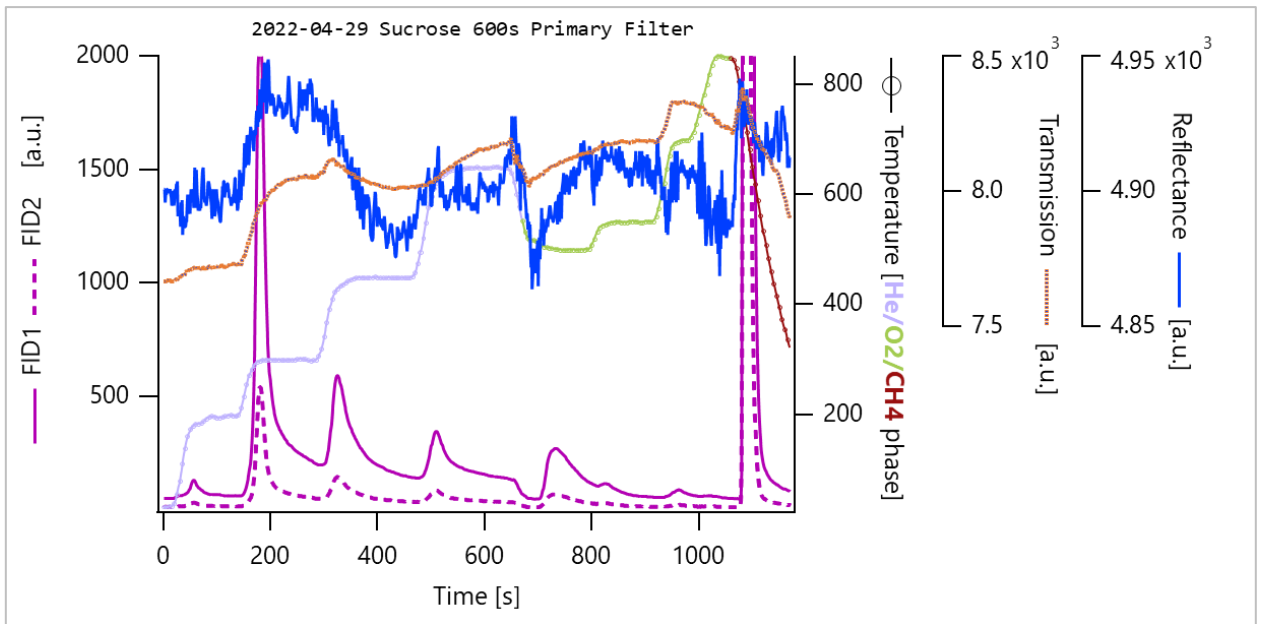

57

58

Figure S5. Thermogram of Sucrose - Primary Filter showing solid phase matter

59

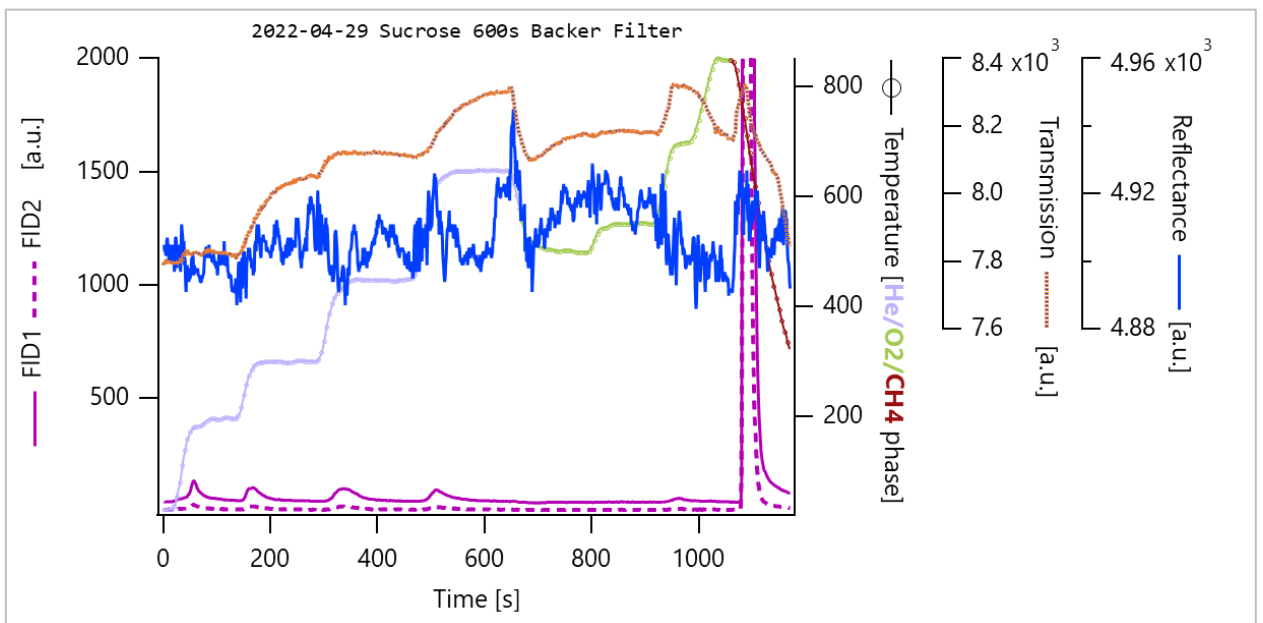

60

61

Figure S6. Thermogram of Sucrose - Backer Filter showing gas phase matter

62

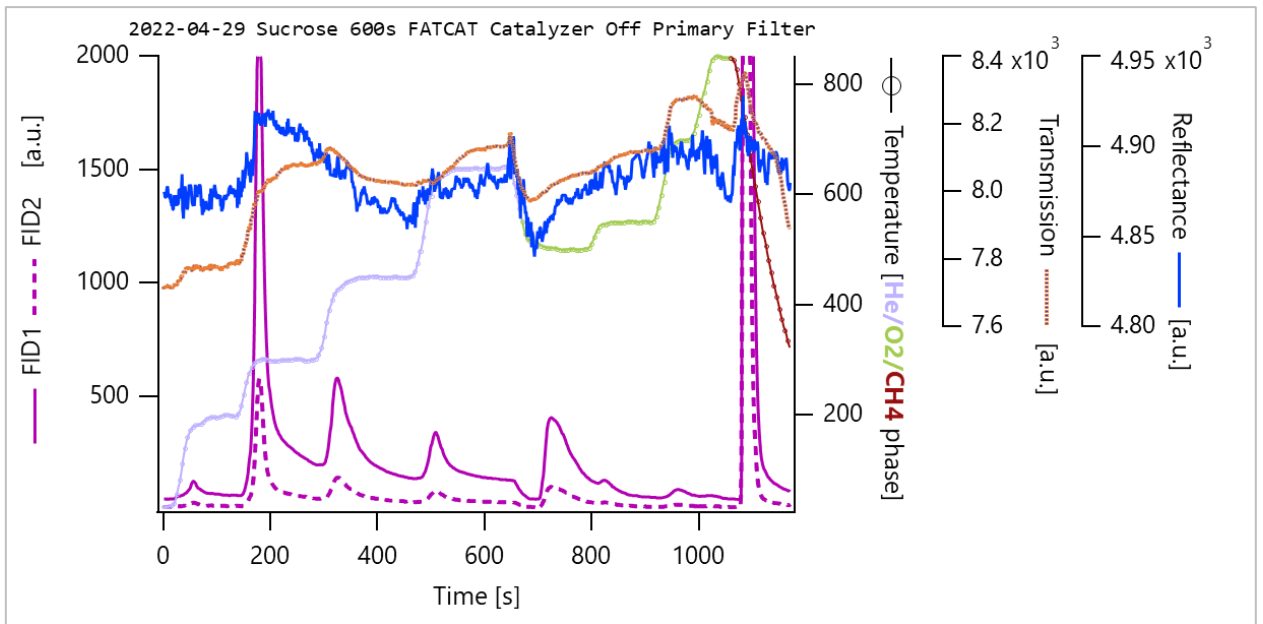

63

64 Figure S7. Thermogram of Sucrose (associated with FATCAT with Catalyzer OFF
 65 data) - Primary Filter showing solid phase matter

66

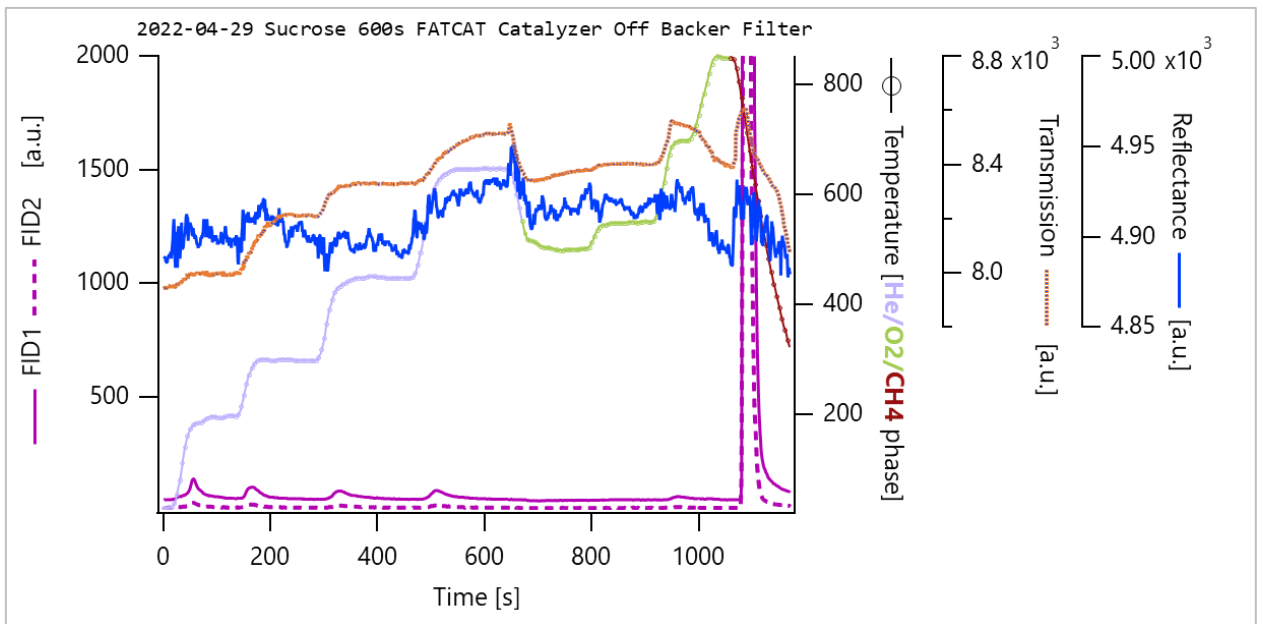

67

68 Figure S8. Thermogram of Sucrose (associated with FATCAT with Catalyzer OFF
 69 data) - Backer Filter showing gas phase matter

70

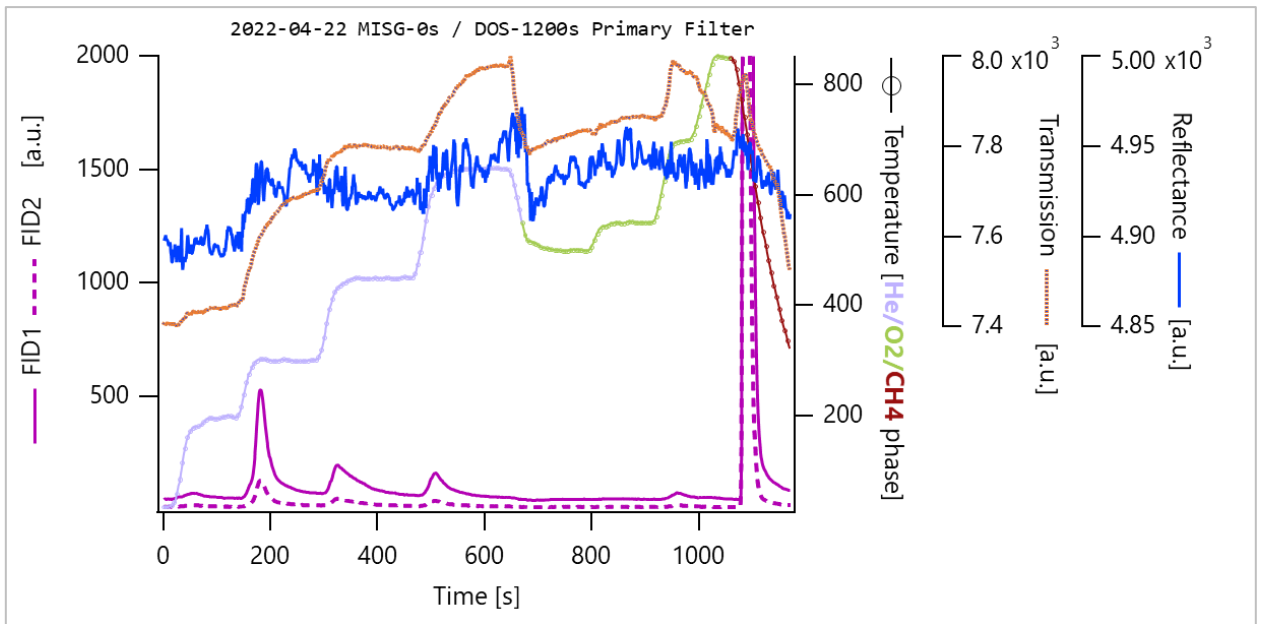

71

72 Figure S9. Thermogram of Mixed Deposition of Mini Inverted Soot Generator
 73 output and Diocetyl Sebacate (DOS) – Primary Filter showing solid phase matter

74

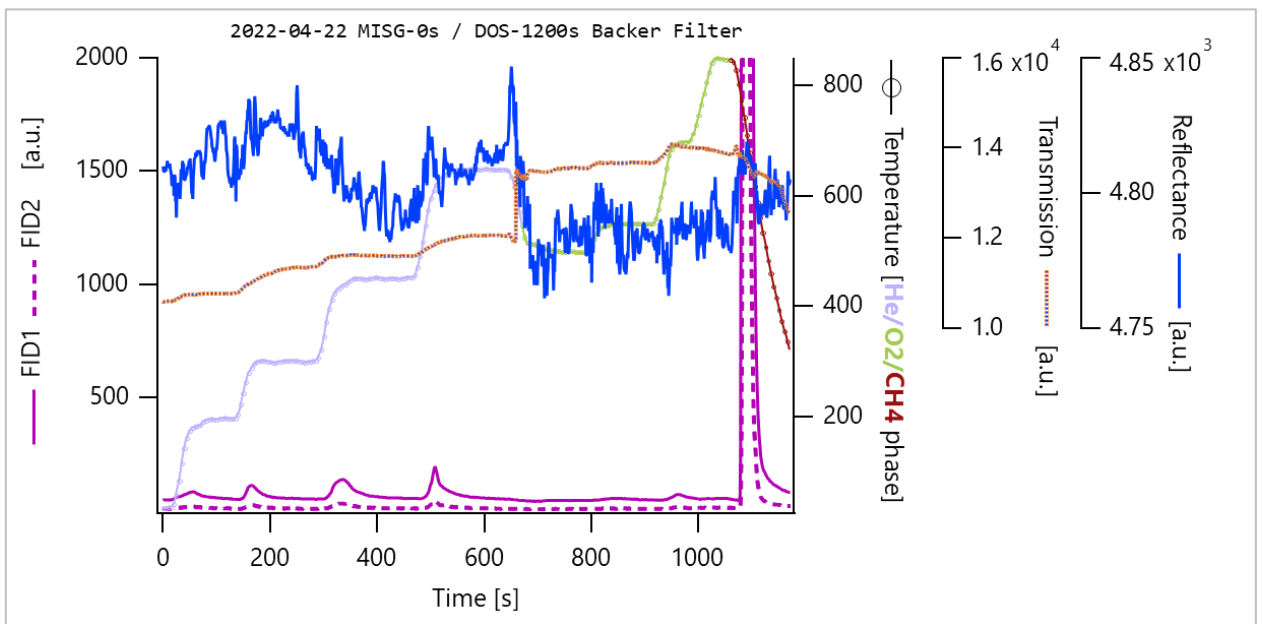

75

76 Figure S10. Thermogram of Mixed Deposition of Mini Inverted Soot Generator
 77 output and Diocetyl Sebacate – Backer Filter showing gas phase matter

78

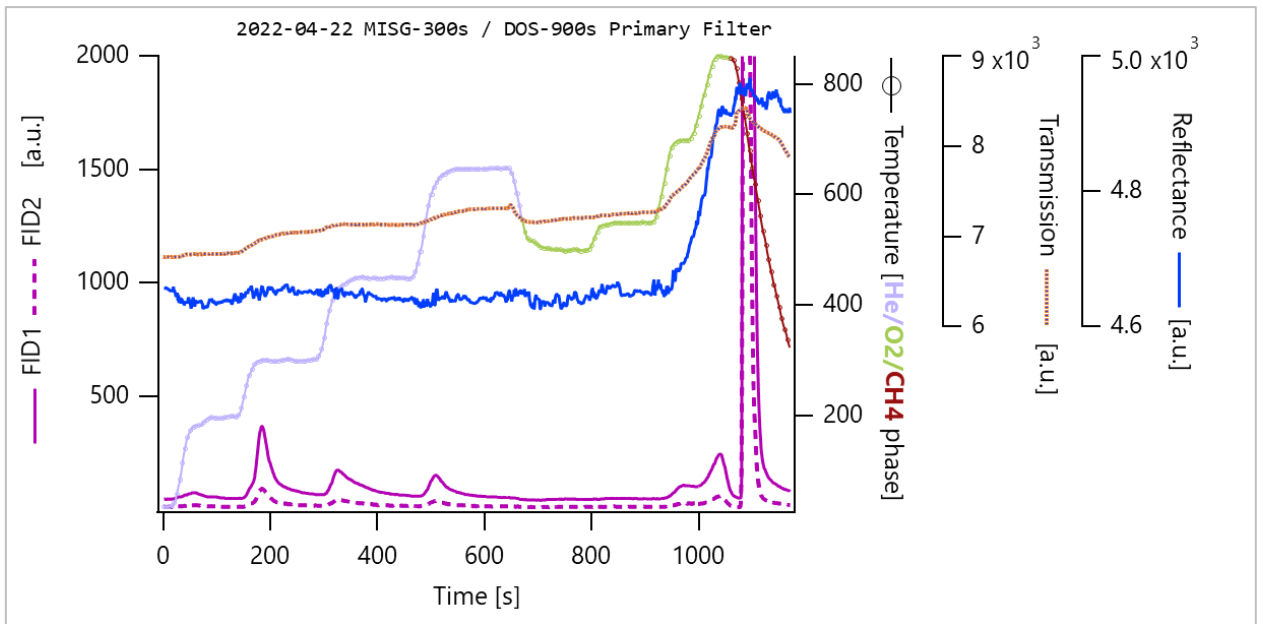

79

80 Figure S11. Thermogram of Mixed Deposition of Mini Inverted Soot Generator
 81 output and Dioctyl Sebacate - Primary Filter showing solid phase matter

82

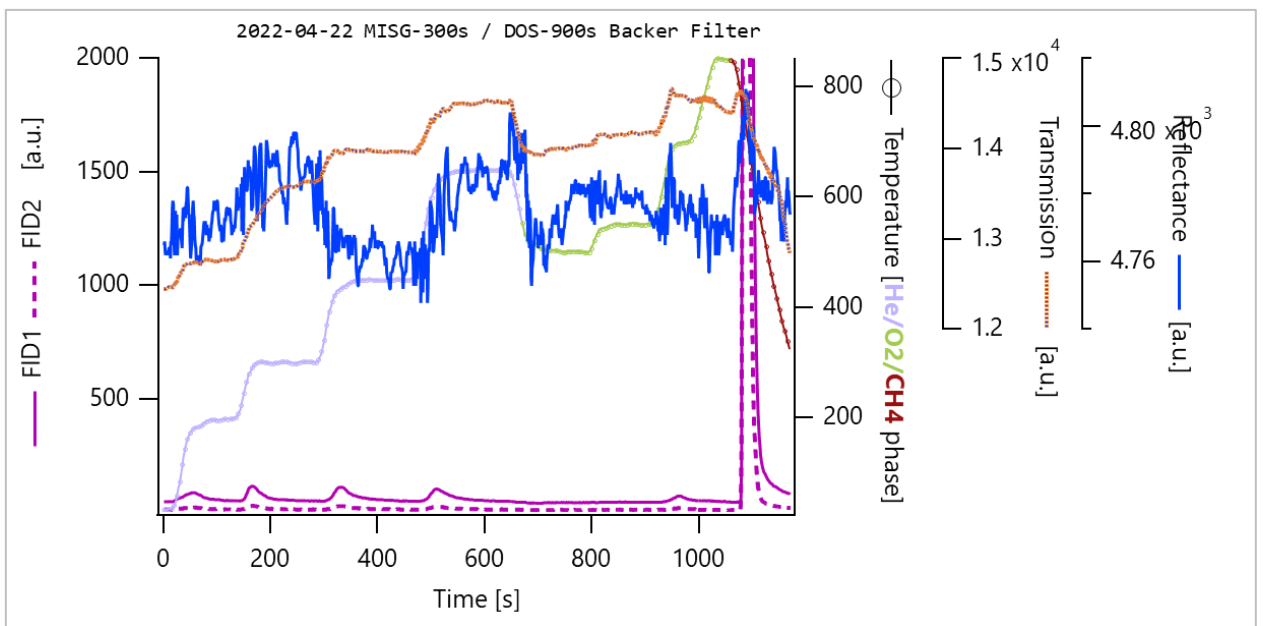

83

84 Figure S12. Thermogram of Mixed Deposition of Mini Inverted Soot Generator
 85 output and Dioctyl Sebacate - Backer Filter showing gas phase matter

86

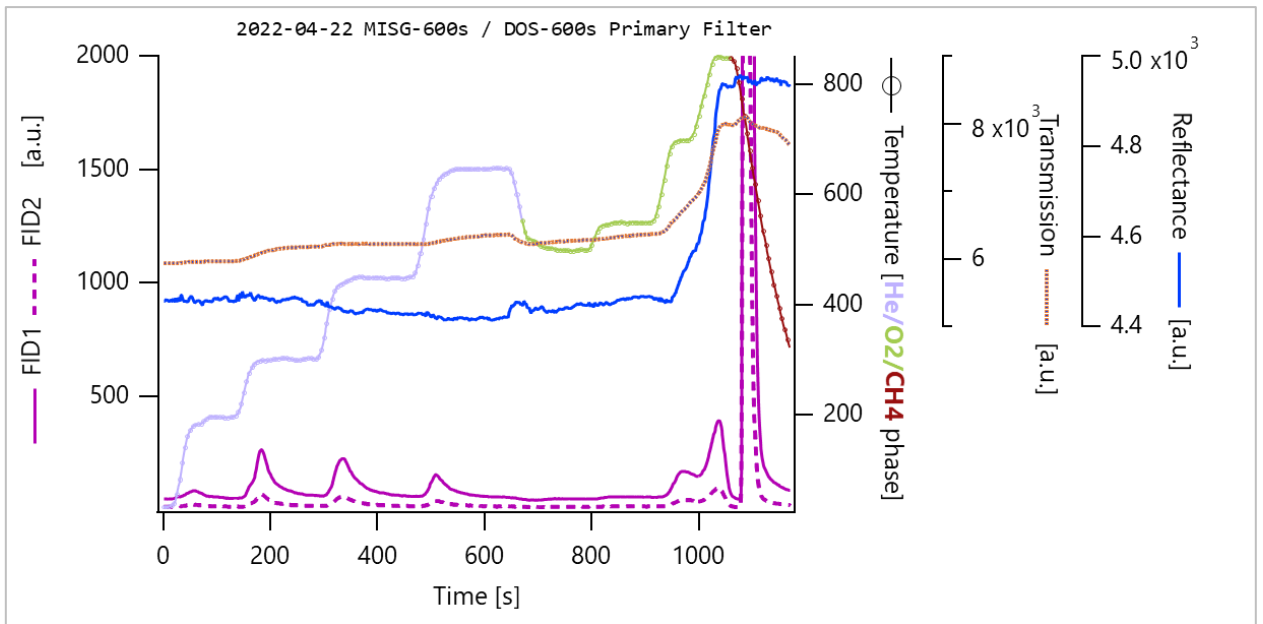

87

88 Figure S13. Thermogram of Mixed Deposition of Mini Inverted Soot Generator

89 output and Dioctyl Sebacate - Primary Filter showing solid phase matter

90

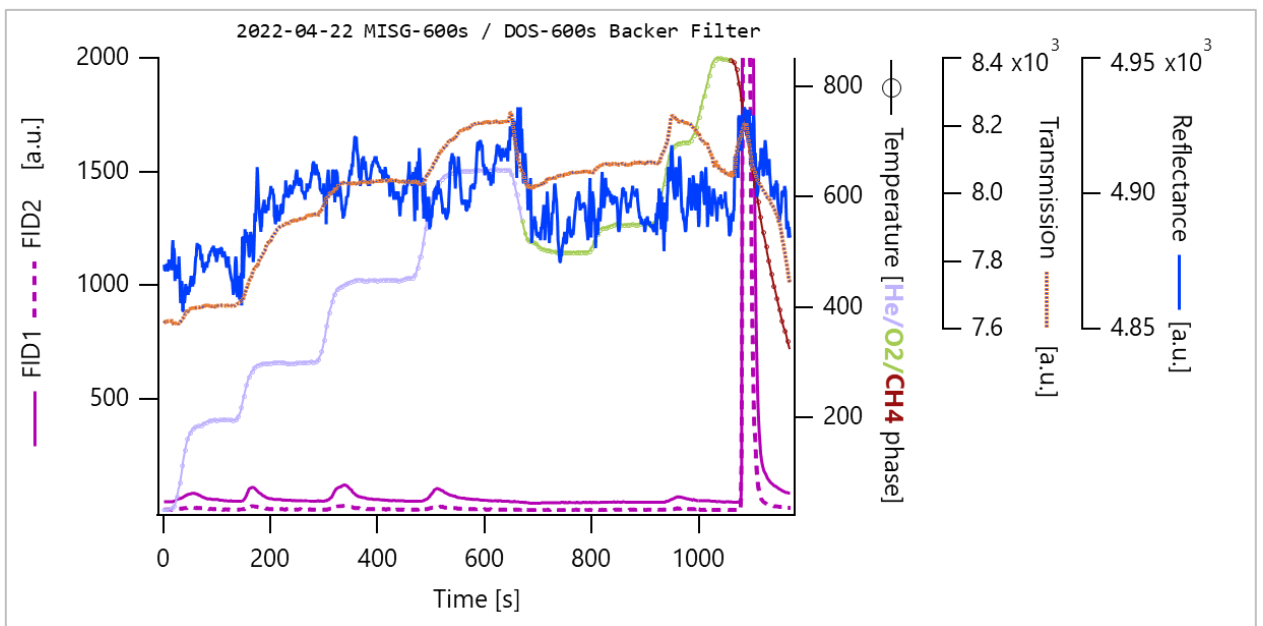

91

92 Figure S14. Thermogram of Mixed Deposition of Mini Inverted Soot Generator

93 output and Dioctyl Sebacate - Backer Filter showing gas phase matter

94

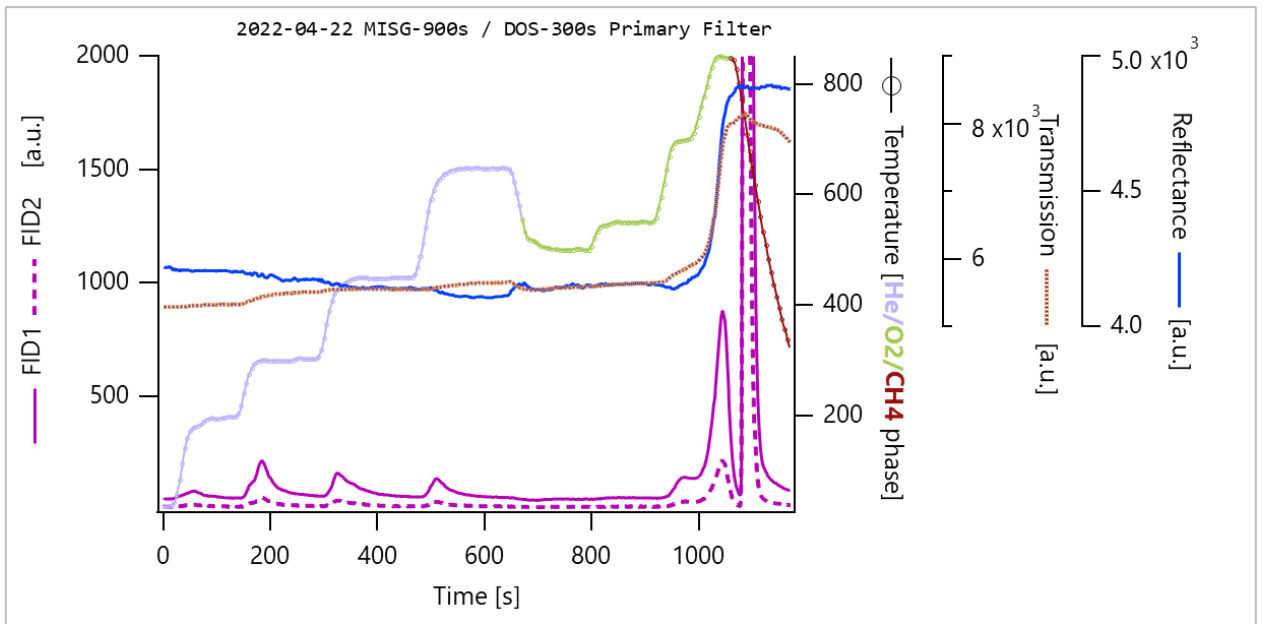

95

96 Figure S15. Thermogram of Mixed Deposition of Mini Inverted Soot Generator

97 output and Dioctyl Sebacate - Primary Filter showing solid phase matter

98

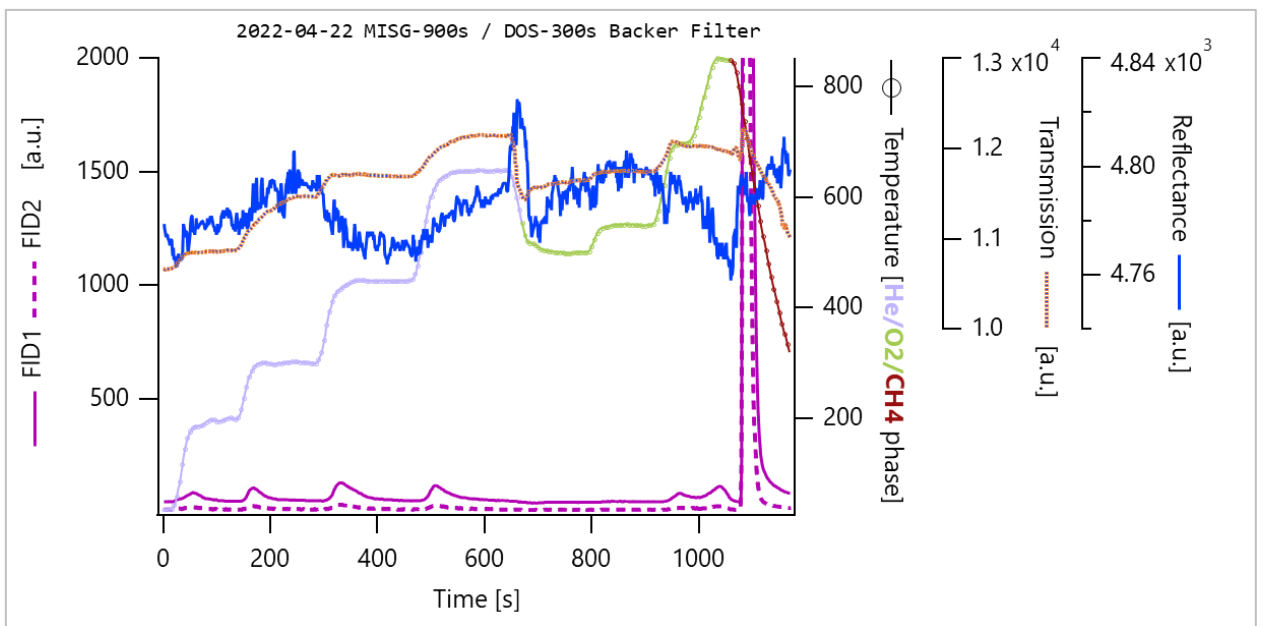

99

100 Figure S16. Thermogram of Mixed Deposition of Mini Inverted Soot Generator

101 output and Dioctyl Sebacate - Backer Filter showing gas phase matter

102

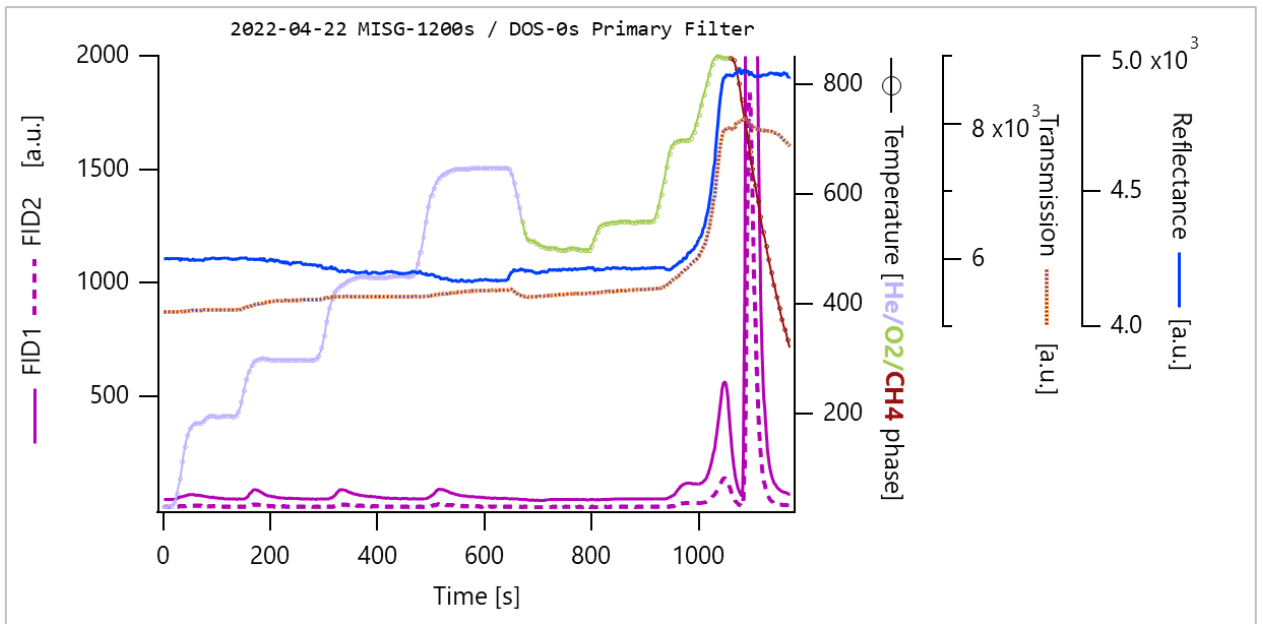

103

104

Figure S17. Thermogram of Mixed Deposition of Mini Inverted Soot Generator output and Dioctyl Sebacate – Primary Filter showing solid phase matter

106

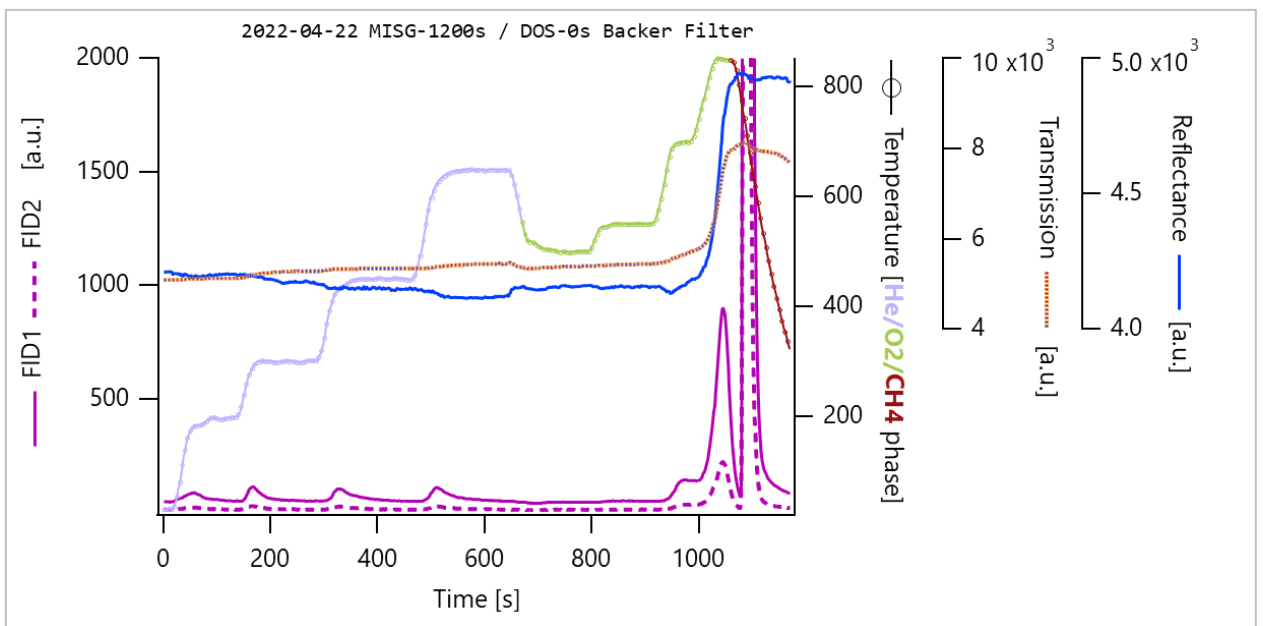

107

108

Figure S18. Thermogram of Mixed Deposition of Mini Inverted Soot Generator output and Dioctyl Sebacate – Backer Filter showing gas phase matter

110

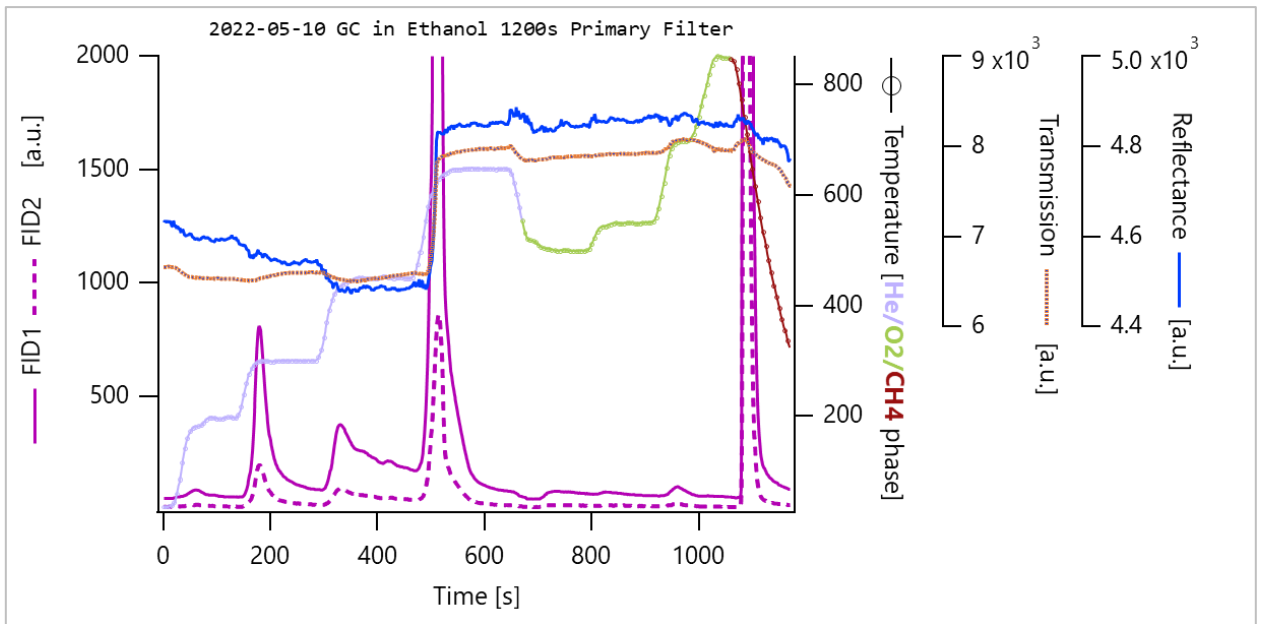

111

112 Figure S19. Thermogram of Glassy Carbon in Ethanol - Primary Filter showing
 113 solid phase matter

114

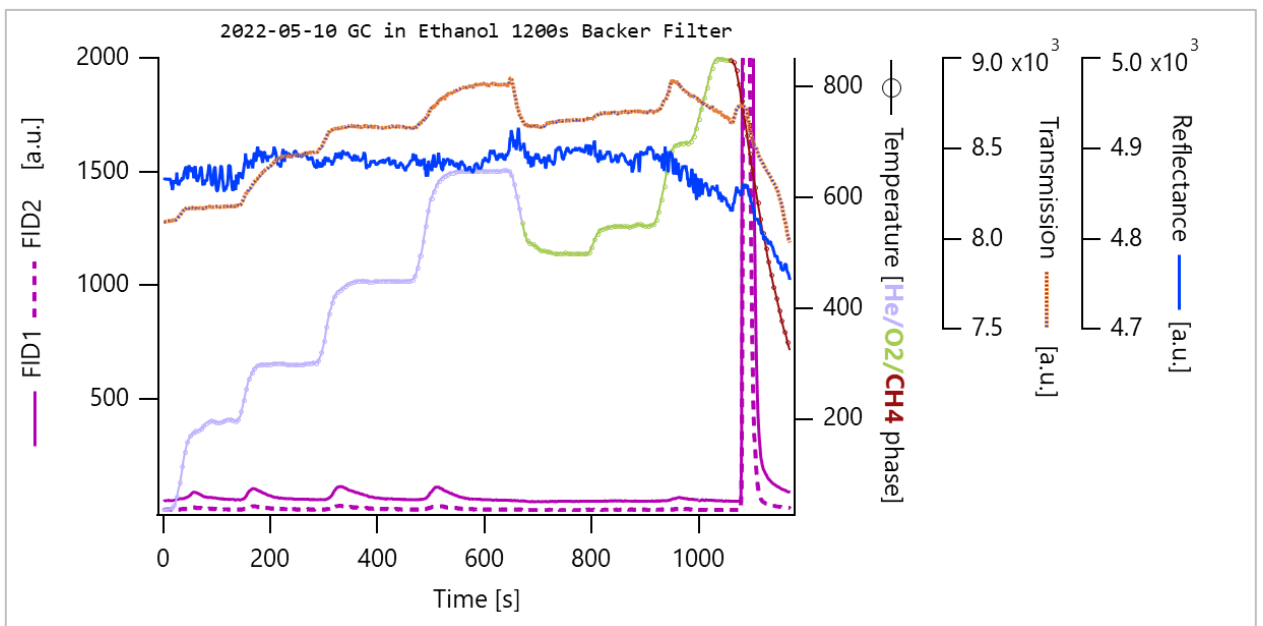

115

116 Figure S20. Thermogram of Glassy Carbon in Ethanol - Backer Filter showing gas
 117 phase matter

118

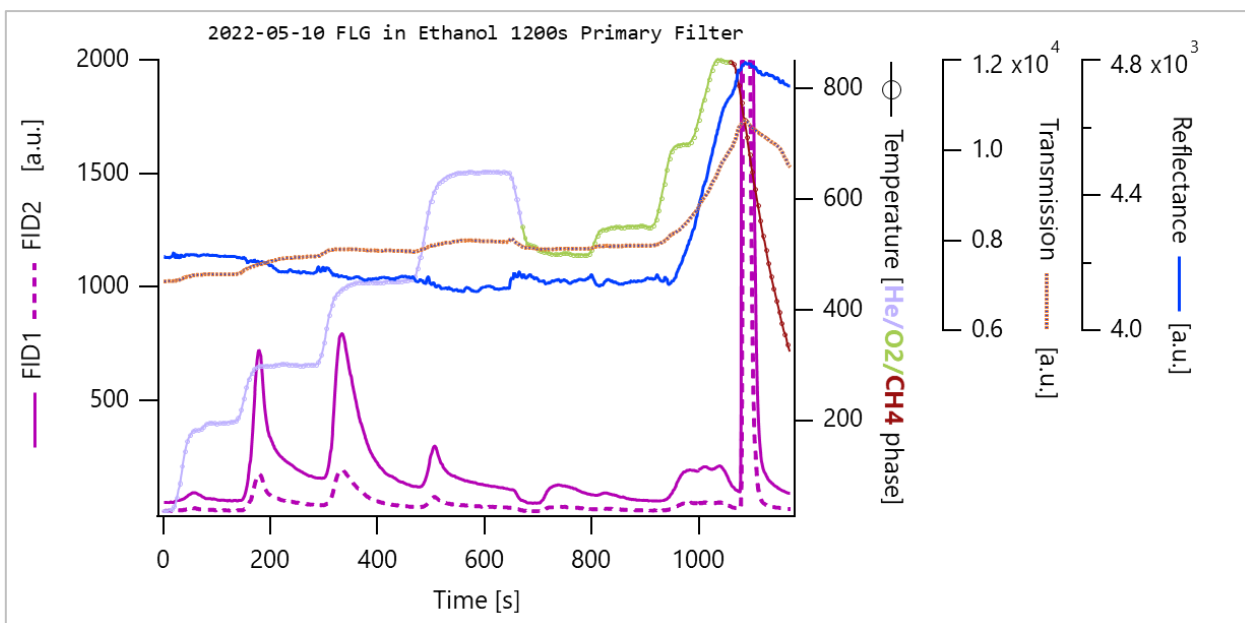

119

120 Figure S21. Thermogram of Few Layer Graphene in Ethanol - Primary Filter

121 showing solid phase matter

122

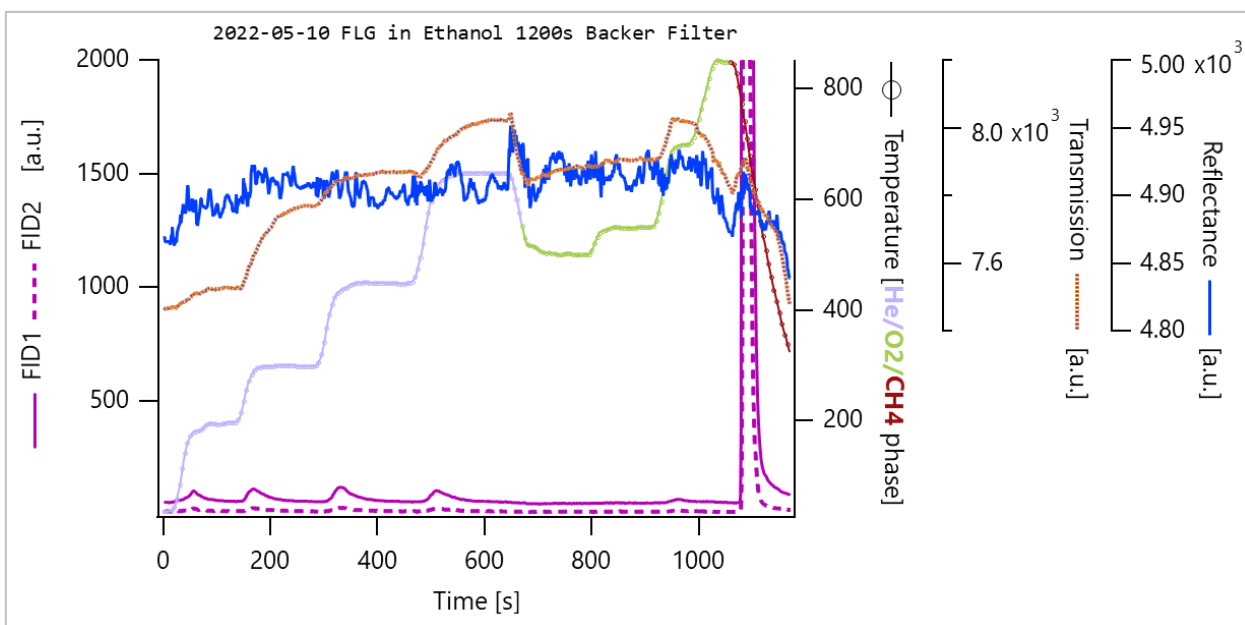

123

124 Figure S22. Thermogram of Few Layer Graphene in Ethanol - Backer Filter

125 showing gas phase matter

126

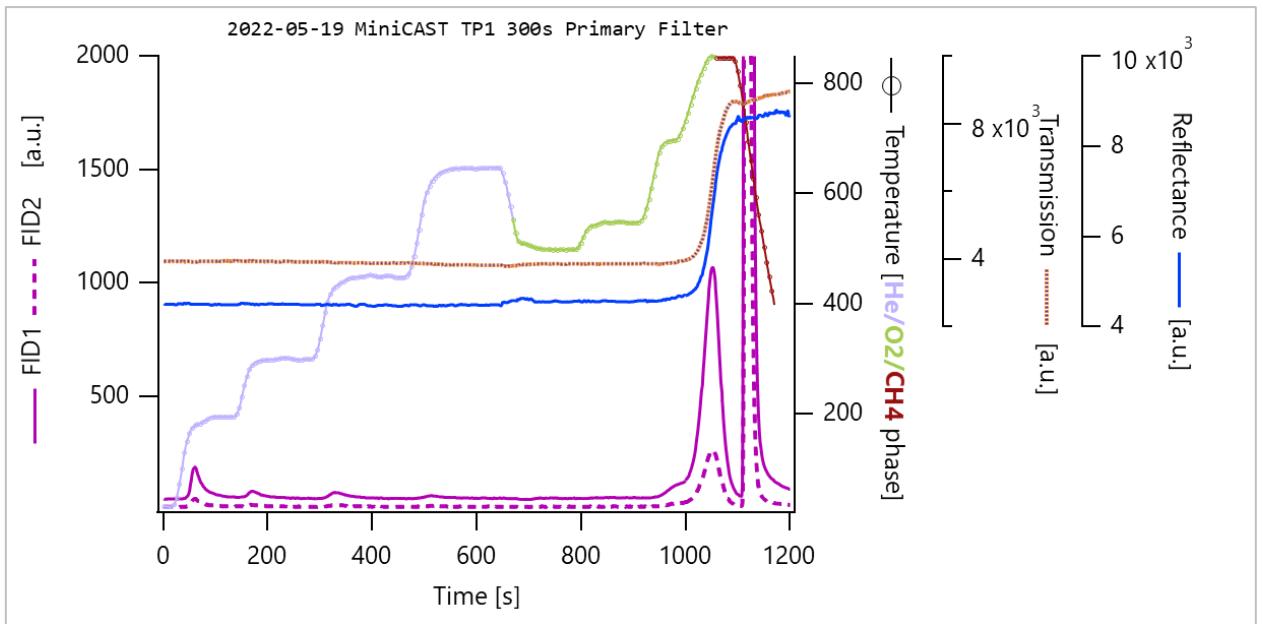

127

128 Figure S23. Thermogram of MiniCAST Black Carbon, Test Point 1 - Primary Filter
 129 showing solid phase matter

130

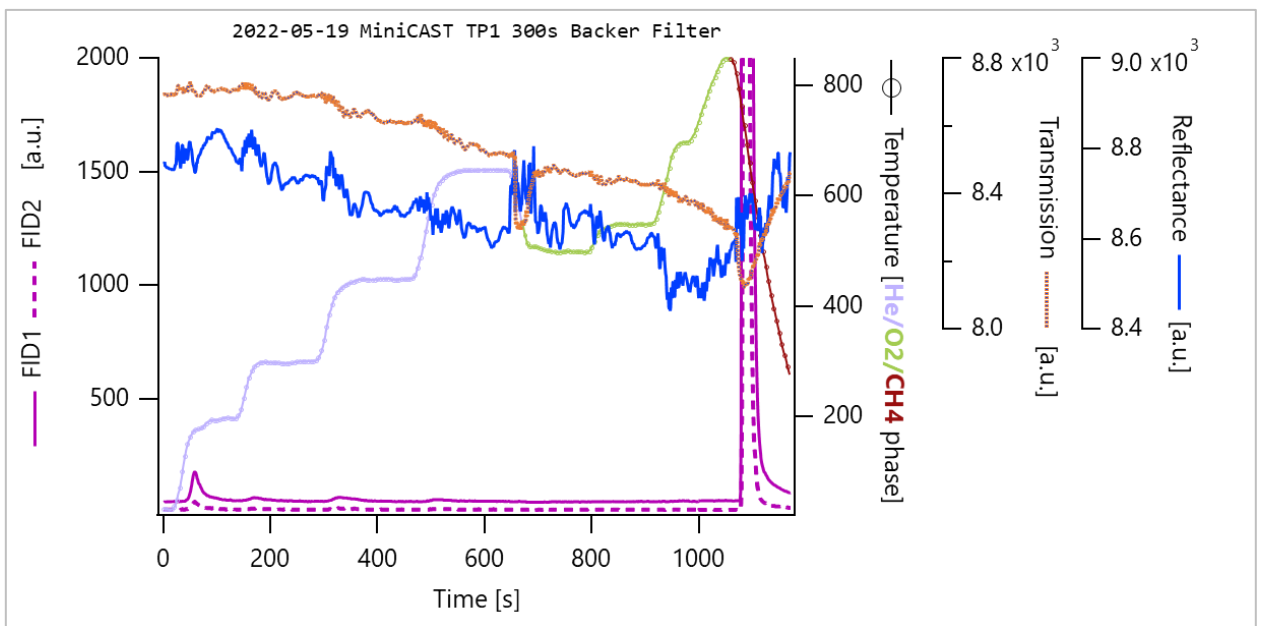

131

132 Figure S24. Thermogram of MiniCAST Black Carbon, Test Point 1 - Backer Filter
 133 showing gas phase matter

134

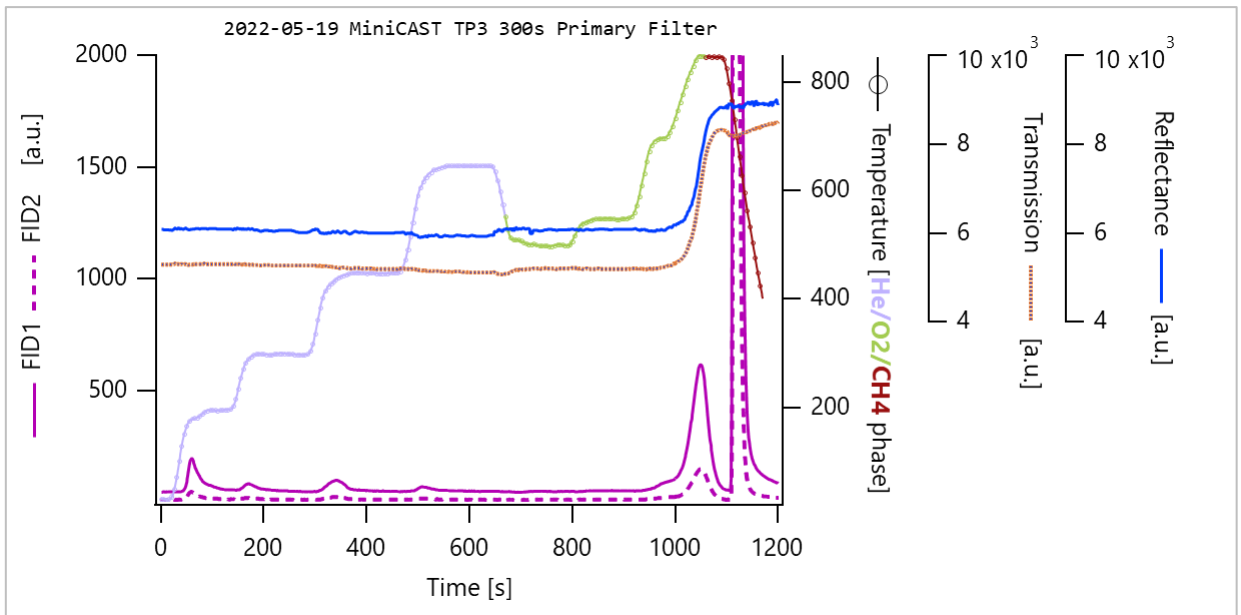

135

136 Figure S25. Thermogram of MiniCAST Black Carbon, Test Point 3 - Primary Filter
 137 showing solid phase matter

138

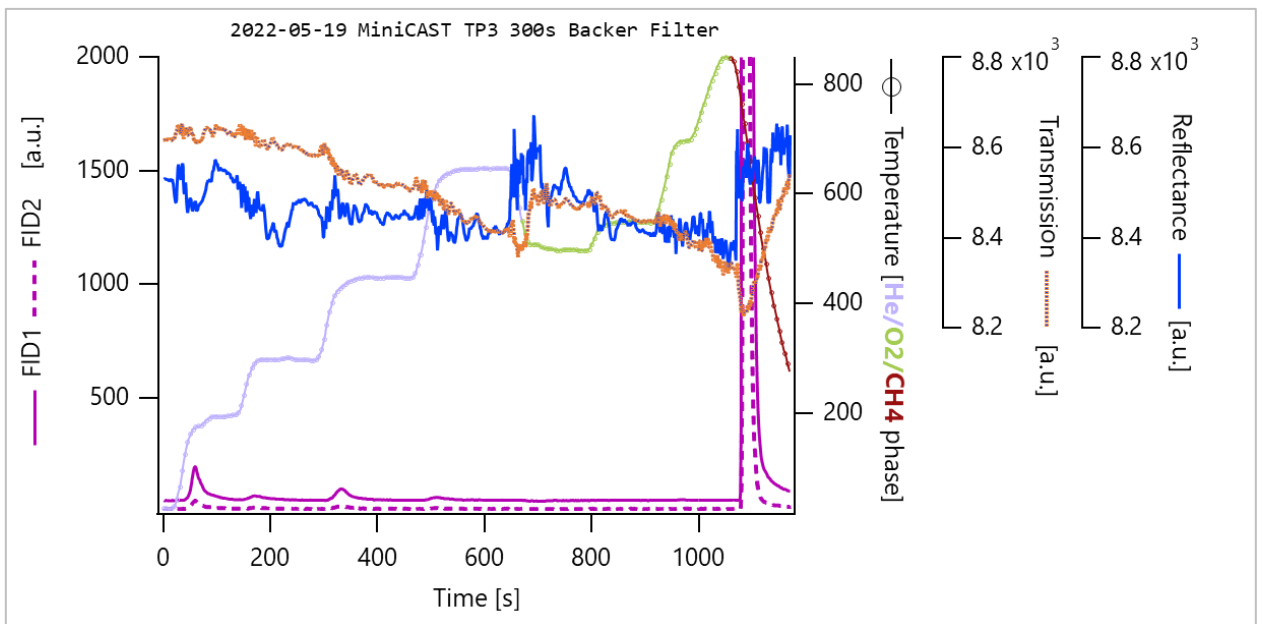

139

140 Figure S26. Thermogram of MiniCAST Black Carbon, Test Point 3 - Backer Filter
 141 showing gas phase matter

142

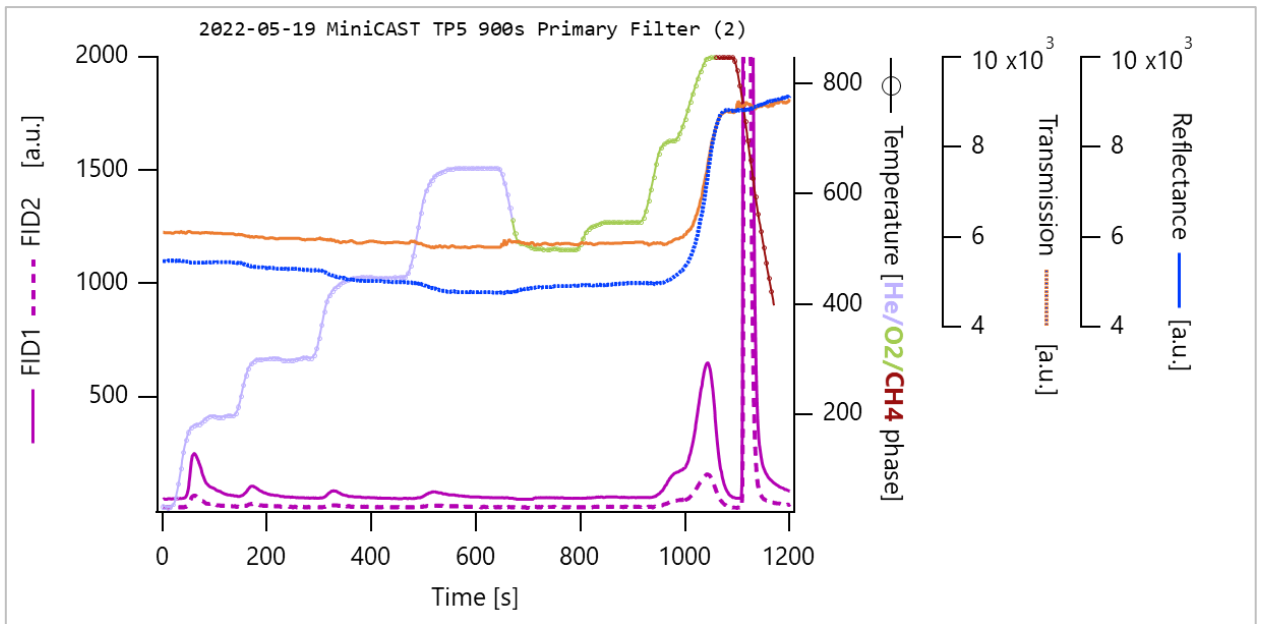

143

144 Figure S27. Thermogram of MiniCAST Black Carbon, Test Point 5 - Primary Filter
 145 showing solid phase matter

146

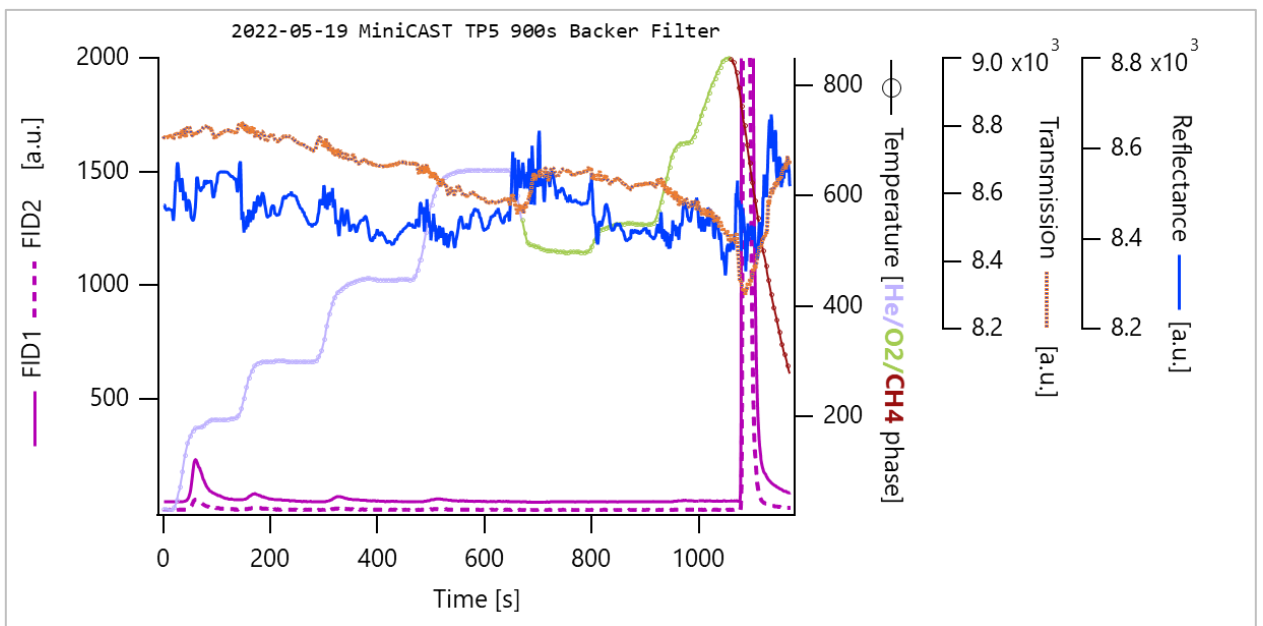

147

148 Figure S28. Thermogram of MiniCAST Black Carbon, Test Point 3 - Backer Filter
 149 showing gas phase matter

150

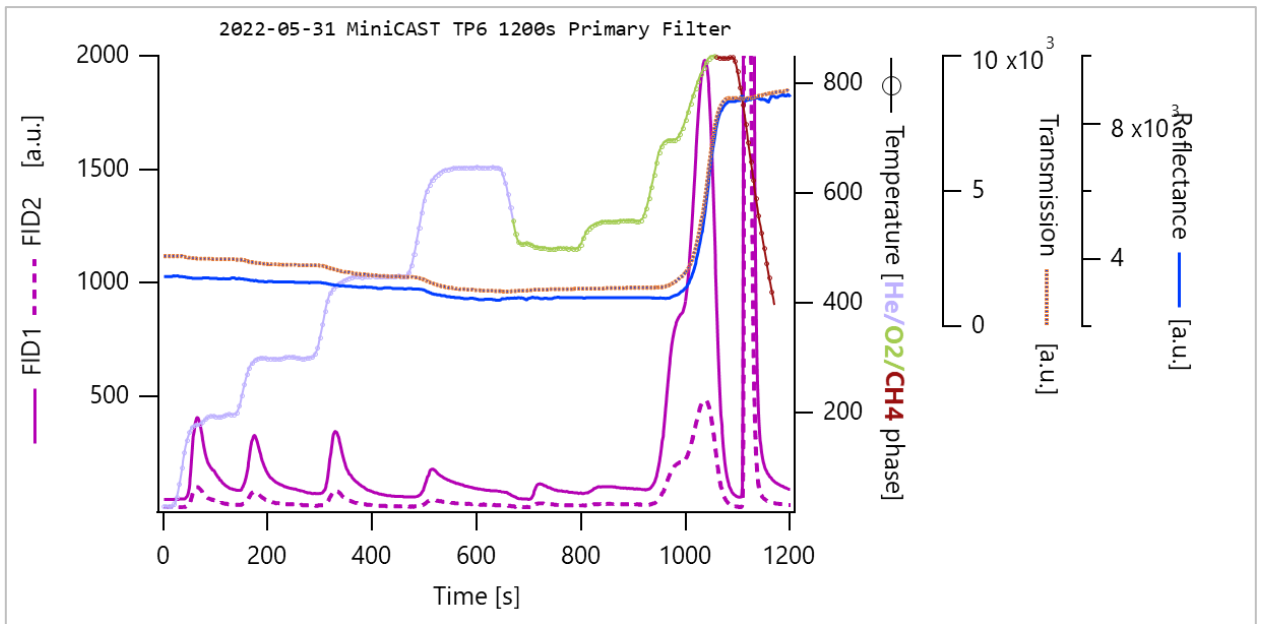

151

152 Figure S29. Thermogram of MiniCAST Black Carbon, Test Point 6 - Primary Filter
 153 showing solid phase matter

154

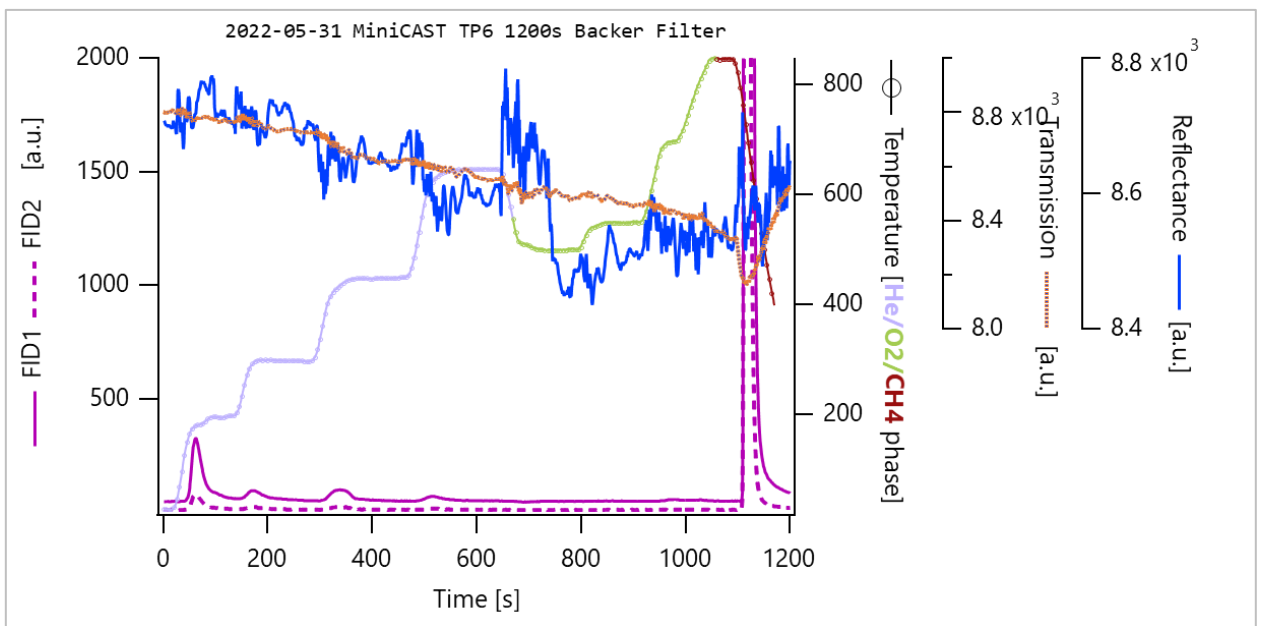

155

156 Figure S30. Thermogram of MiniCAST Black Carbon, Test Point 6 - Backer Filter
 157 showing gas phase matter

158

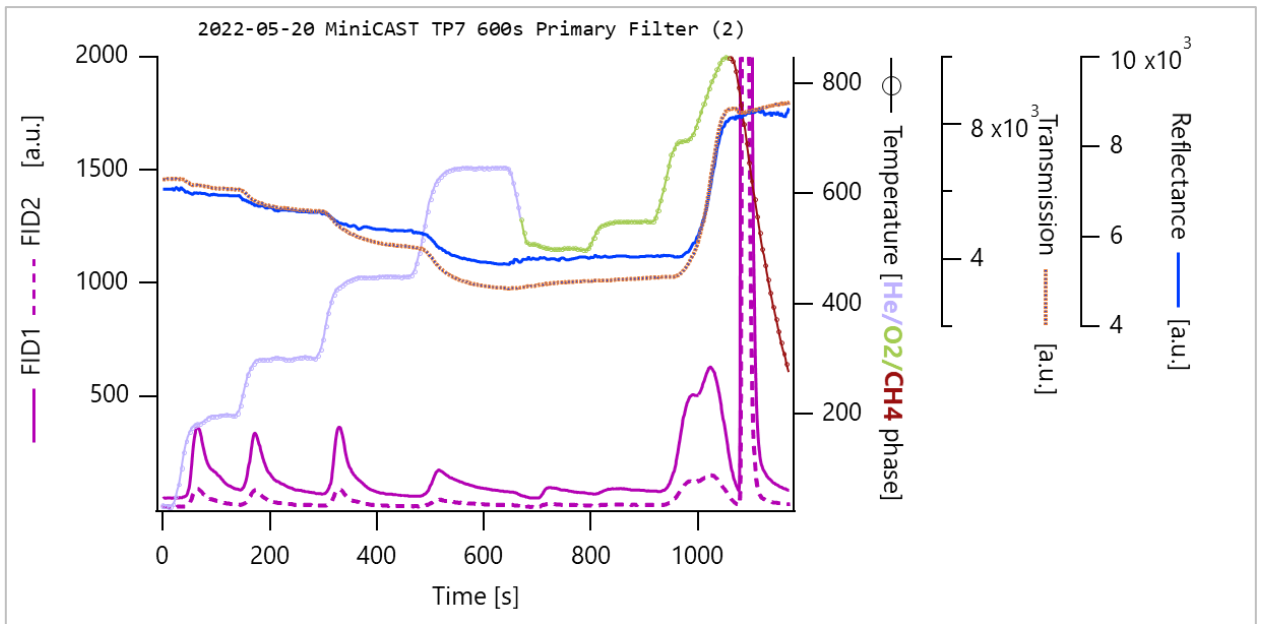

159

160 Figure S31. Thermogram of MiniCAST Black Carbon, Test Point 7 - Primary Filter
 161 showing solid phase matter

162

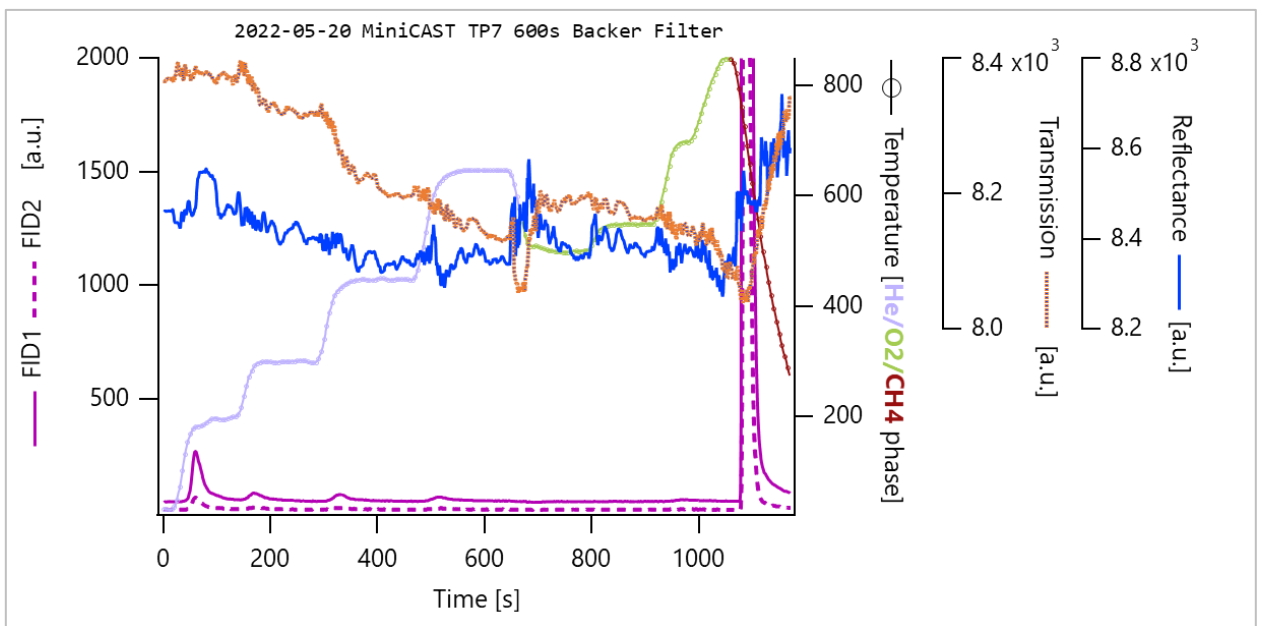

163

164 Figure S32. Thermogram of MiniCAST Black Carbon, Test Point 7 - Backer Filter
 165 showing gas phase matter

166

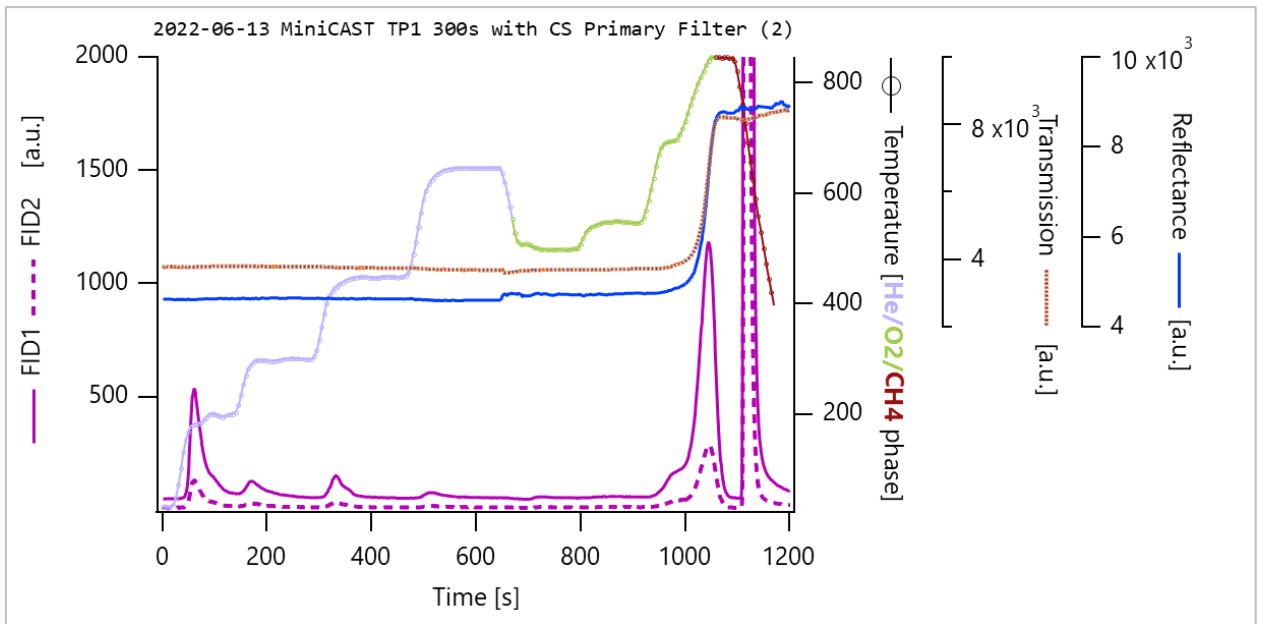

167

168

Figure S33. Thermogram of MiniCAST Black Carbon, Test Point 1 conditioned with a Catalytic Stripper @ 350°C - Primary Filter showing solid phase matter

169

170

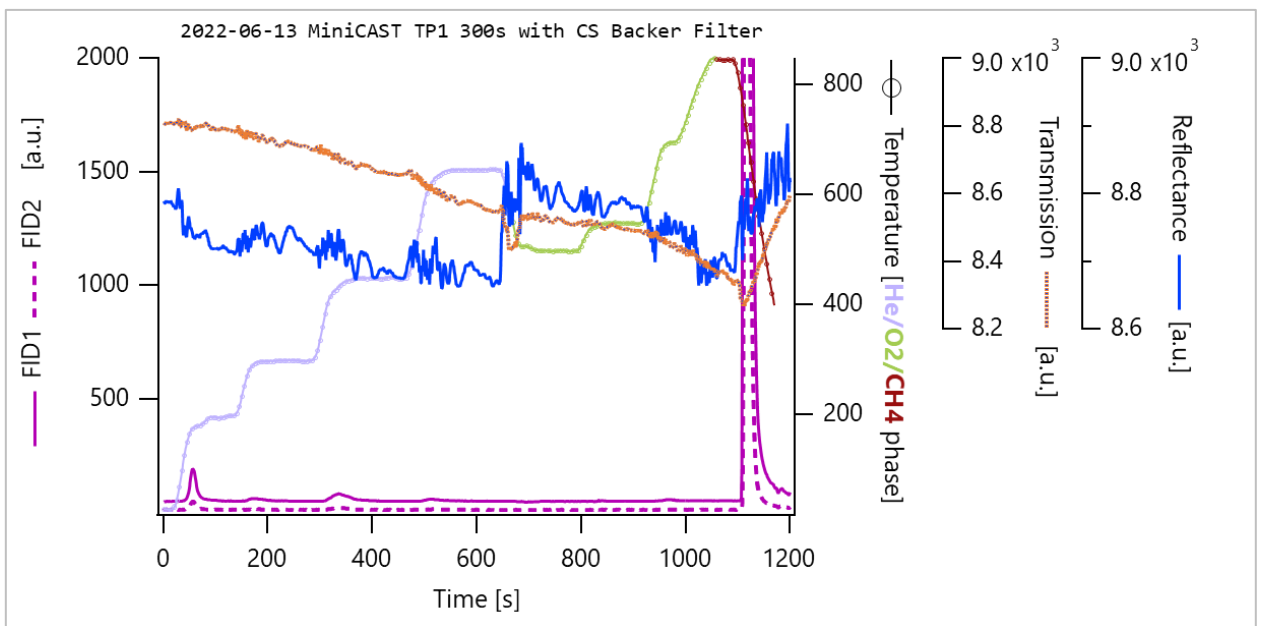

171

172

Figure S34. Thermogram of MiniCAST Black Carbon, Test Point 1 conditioned with a Catalytic Stripper @ 350°C - Backer Filter showing gas phase matter

173

174

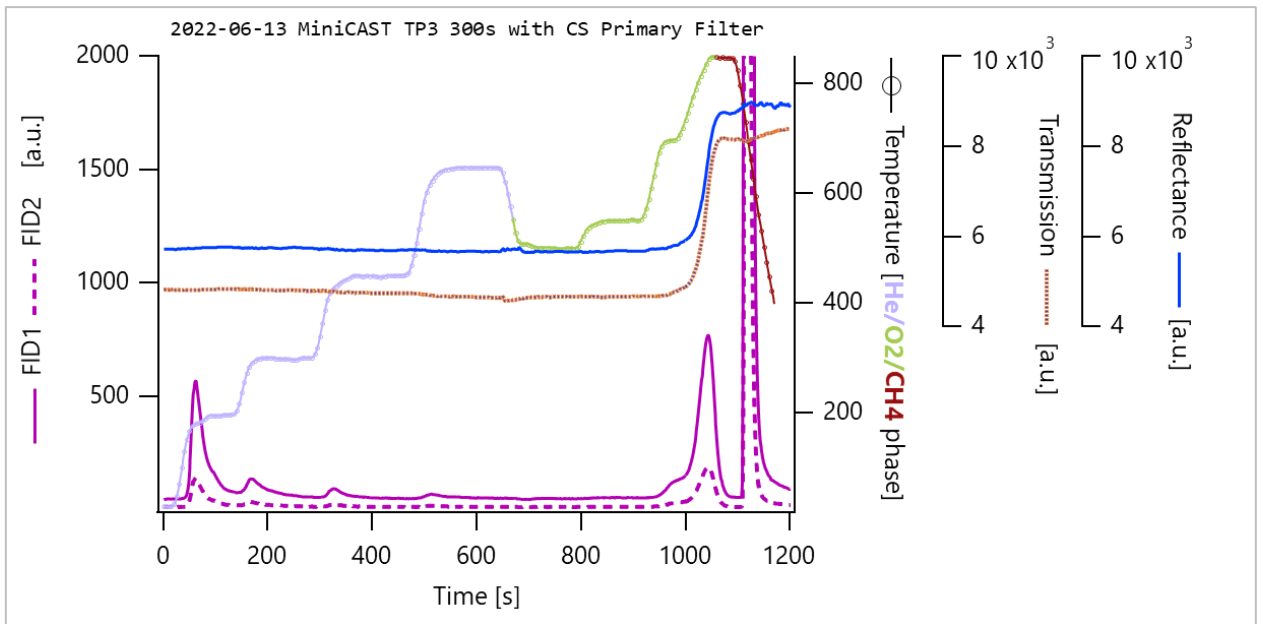

175

176

Figure S35. Thermogram of MiniCAST Black Carbon, Test Point 3 conditioned with a Catalytic Stripper @ 350°C - Primary Filter showing solid phase matter

177

178

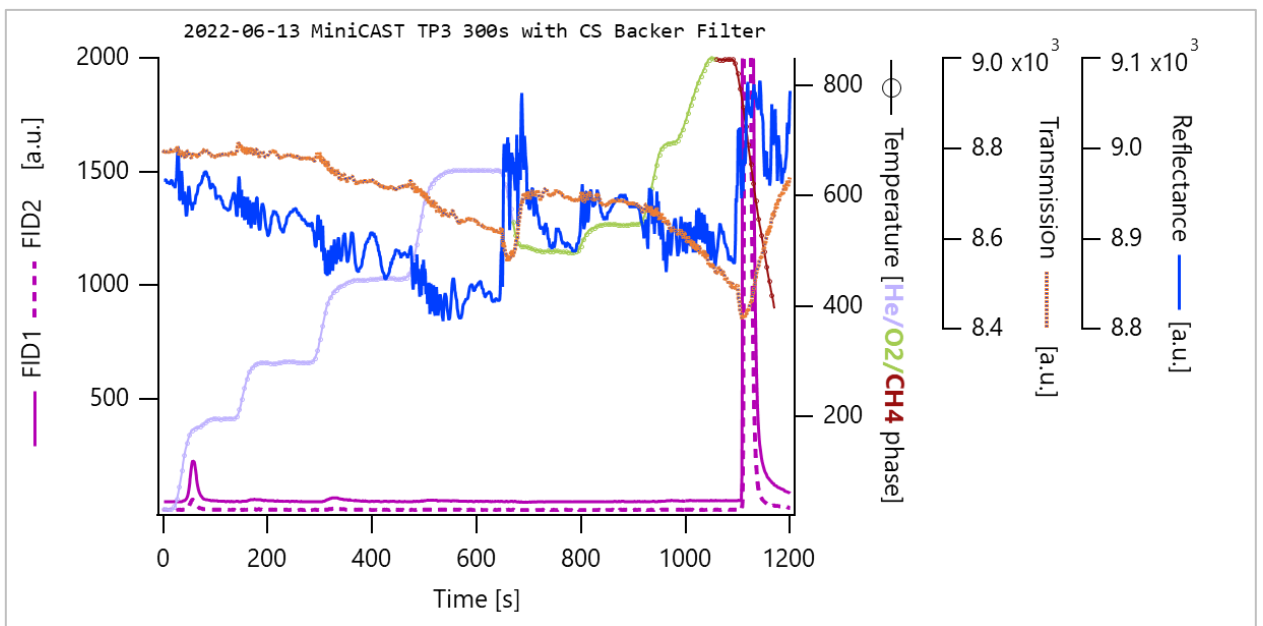

179

180

Figure S36. Thermogram of MiniCAST Black Carbon, Test Point 3 conditioned with a Catalytic Stripper @ 350°C - Backer Filter showing gas phase matter

181

182

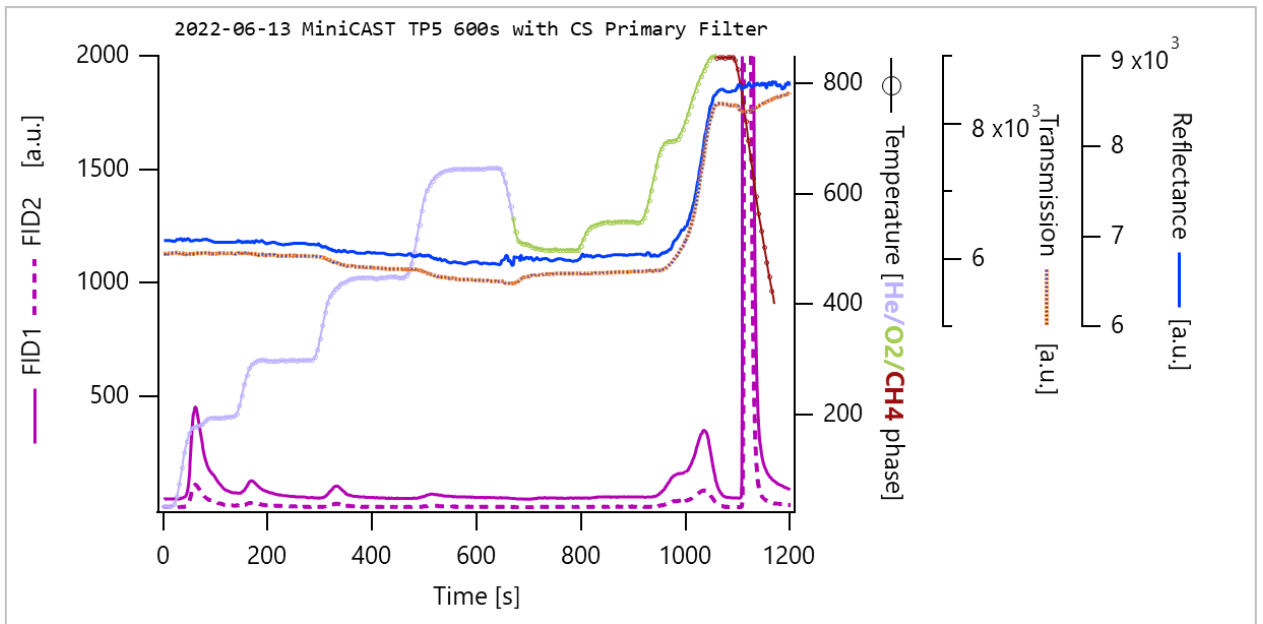

183

184 Figure S37. Thermogram of MiniCAST Black Carbon, Test Point 5 conditioned with
 185 a Catalytic Stripper @ 350°C - Primary Filter showing solid phase matter

186

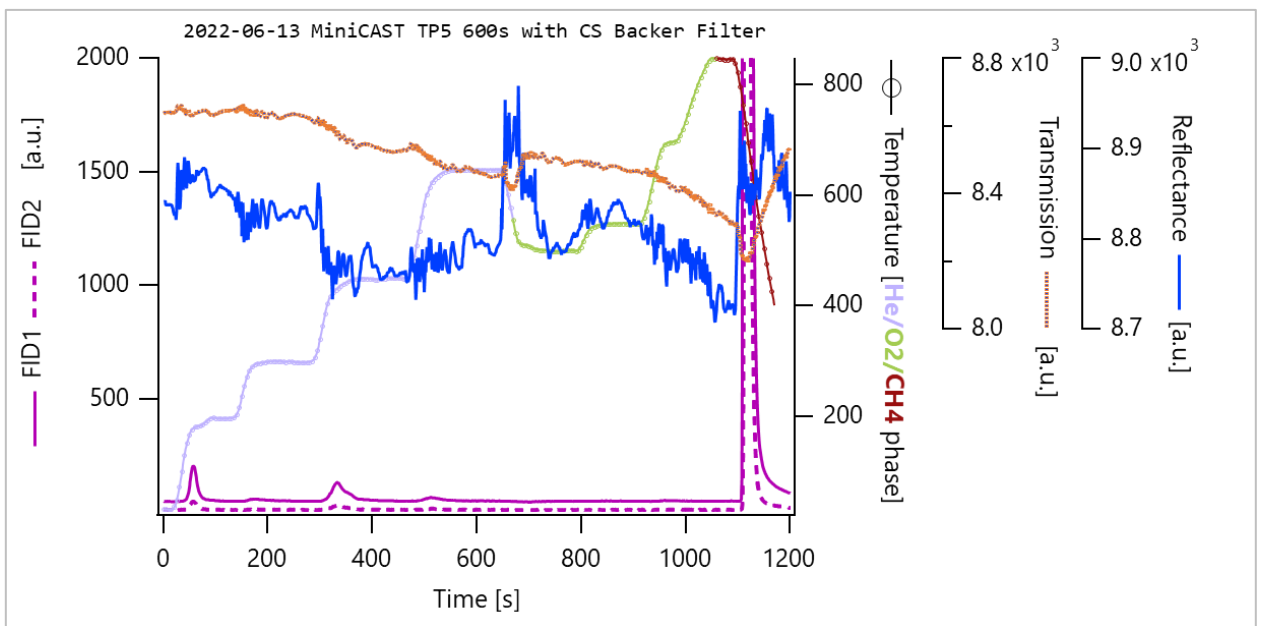

187

188 Figure S38. Thermogram of MiniCAST Black Carbon, Test Point 5 conditioned with
 189 a Catalytic Stripper @ 350°C - Backer Filter showing gas phase matter

190

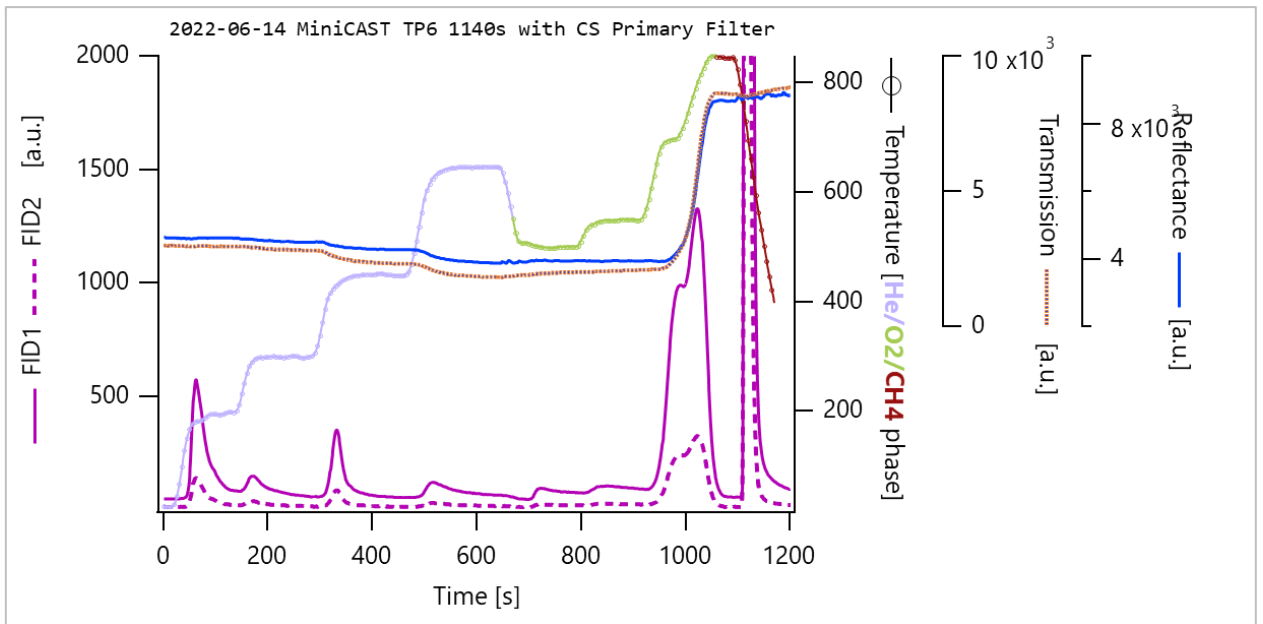

191

192

Figure S39. Thermogram of MiniCAST Black Carbon, Test Point 6 conditioned with a Catalytic Stripper @ 350°C - Primary Filter showing solid phase matter

193

194

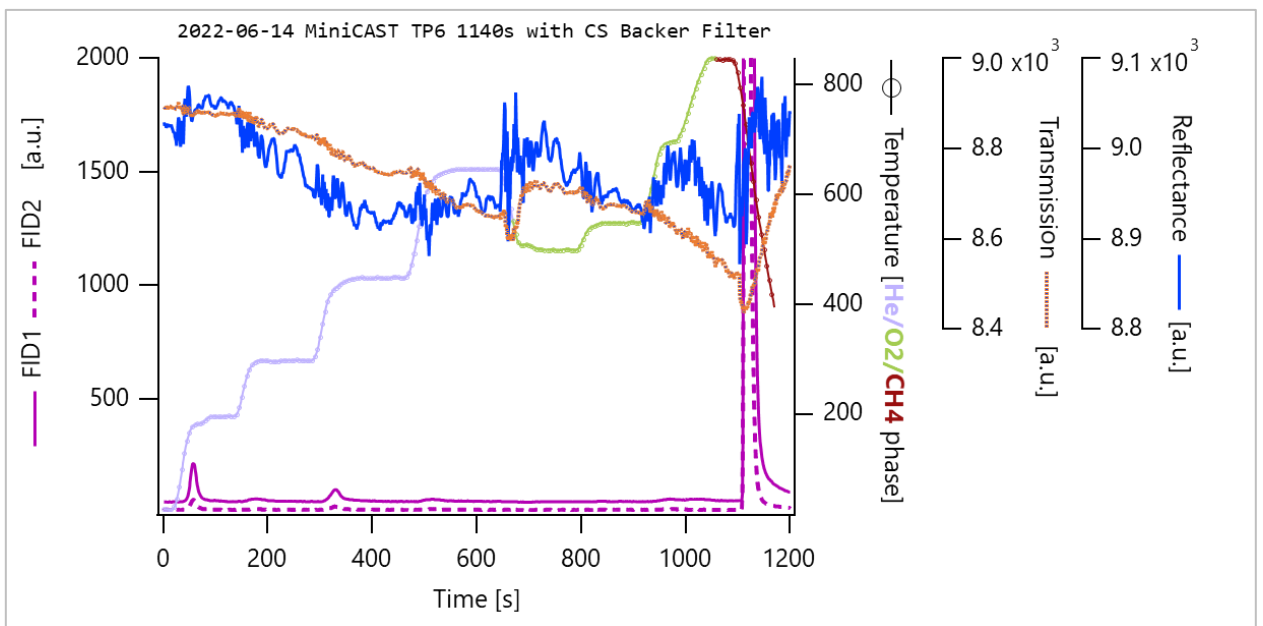

195

196

Figure S40. Thermogram of MiniCAST Black Carbon, Test Point 6 conditioned with a Catalytic Stripper @ 350°C - Backer Filter showing gas phase matter

197

198

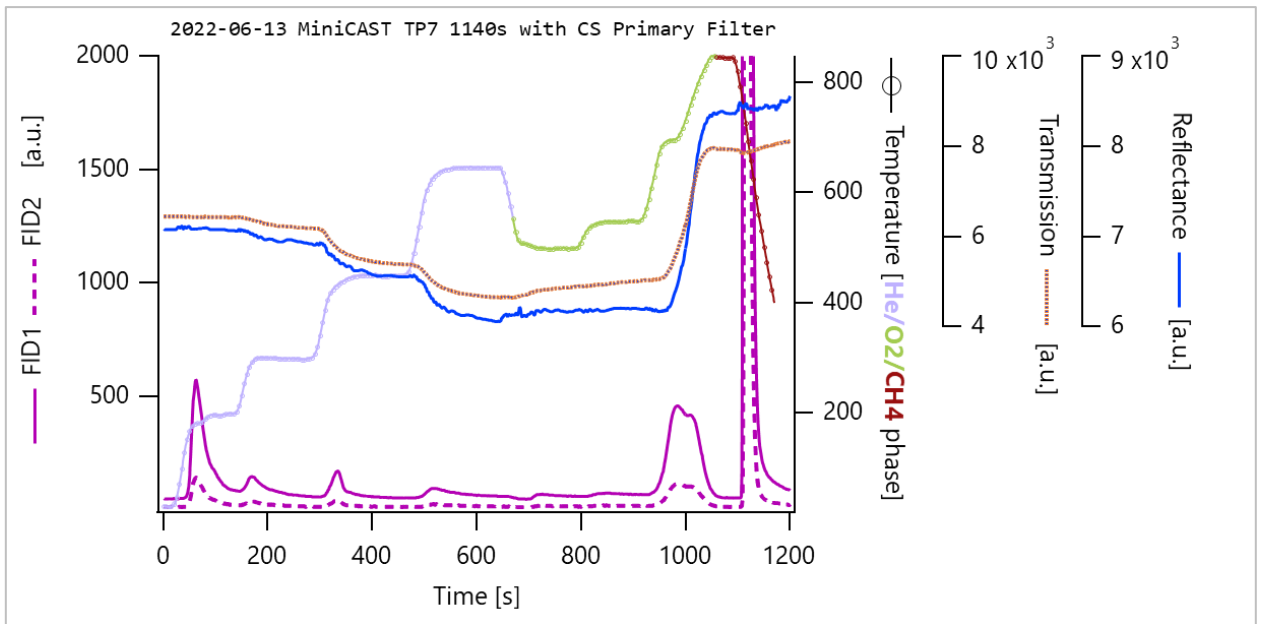

199

200

201 Figure S41. Thermogram of MiniCAST Black Carbon, Test Point 7 conditioned with
 202 a Catalytic Stripper @ 350°C - Primary Filter showing solid phase matter

203

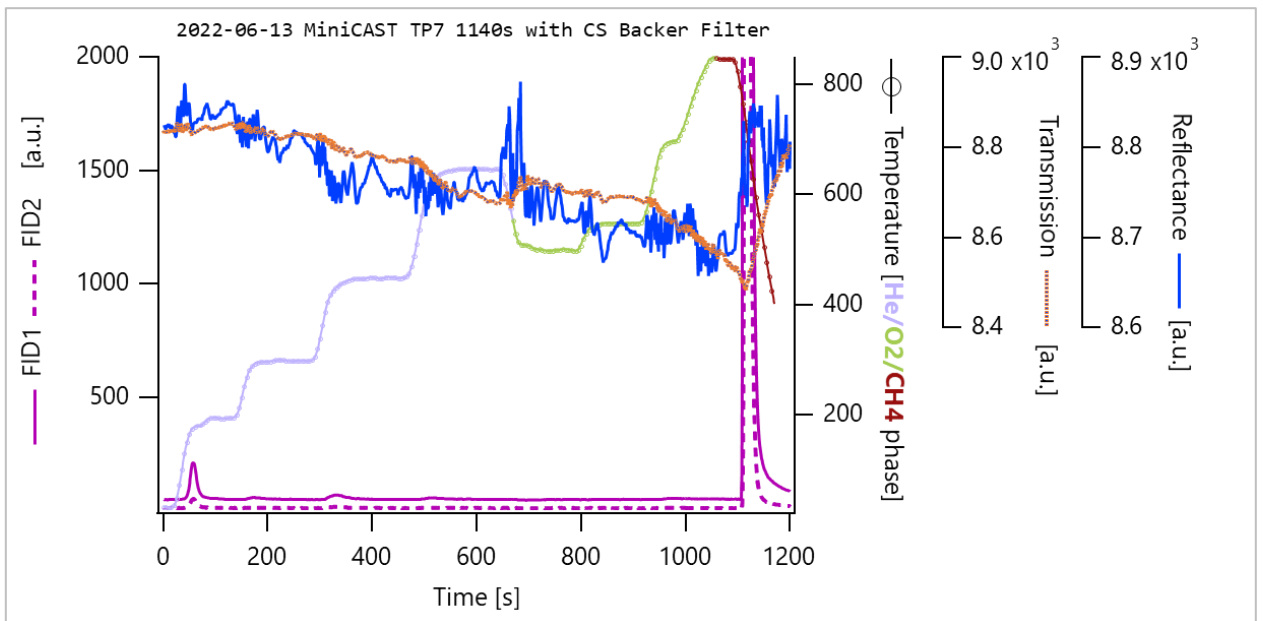

204

205 Figure S42. Thermogram of MiniCAST Black Carbon, Test Point 7 conditioned with
 206 a Catalytic Stripper @ 350°C - Backer Filter showing gas phase matter.