

NRC Publications Archive Archives des publications du CNRC

Fire tests to assess effects of large duct openings on fire resistance of steel-supported floor-ceiling assemblies

Stanzak, W. W.; Berndt, J. E.

For the publisher's version, please access the DOI link below./ Pour consulter la version de l'éditeur, utilisez le lien DOI ci-dessous.

Publisher's version / Version de l'éditeur:

<https://doi.org/10.4224/20338426>

Internal Report (National Research Council Canada. Division of Building Research); no. DBR-IR-423, 1975-12-01

NRC Publications Archive Record / Notice des Archives des publications du CNRC :

<https://nrc-publications.canada.ca/eng/view/object/?id=f006e25e-acdf-43b3-831c-f8359322c0fa>

<https://publications-cnrc.canada.ca/fra/voir/objet/?id=f006e25e-acdf-43b3-831c-f8359322c0fa>

Access and use of this website and the material on it are subject to the Terms and Conditions set forth at

<https://nrc-publications.canada.ca/eng/copyright>

READ THESE TERMS AND CONDITIONS CAREFULLY BEFORE USING THIS WEBSITE.

L'accès à ce site Web et l'utilisation de son contenu sont assujettis aux conditions présentées dans le site

<https://publications-cnrc.canada.ca/fra/droits>

LISEZ CES CONDITIONS ATTENTIVEMENT AVANT D'UTILISER CE SITE WEB.

Questions? Contact the NRC Publications Archive team at

PublicationsArchive-ArchivesPublications@nrc-cnrc.gc.ca. If you wish to email the authors directly, please see the first page of the publication for their contact information.

Vous avez des questions? Nous pouvons vous aider. Pour communiquer directement avec un auteur, consultez la première page de la revue dans laquelle son article a été publié afin de trouver ses coordonnées. Si vous n'arrivez pas à les repérer, communiquez avec nous à PublicationsArchive-ArchivesPublications@nrc-cnrc.gc.ca.

NATIONAL RESEARCH COUNCIL OF CANADA
DIVISION OF BUILDING RESEARCH

FIRE TESTS TO ASSESS EFFECTS OF LARGE
DUCT OPENINGS ON FIRE RESISTANCE OF STEEL-SUPPORTED
FLOOR-CEILING ASSEMBLIES

by

W. W. Stanzak and J. E. Berndt

ANALYZED

Internal Report No. 423
of the
Division of Building Research

Ottawa, December 1975

PREFACE

Fire-resistive suspended ceilings are important building elements for fire protection of structural steel beams, joists and floors. Their construction is restricted and made costly by present requirements for protection of openings for building services that penetrate the fire protective membrane.

A feasibility study to investigate the effectiveness of economical "partial protection" of such openings is described in this report. The information developed is recorded in this form with the thought that it may be published as other research efforts now going on in this area come to maturity.

The first author, Mr. W. W. Stanzak, a mechanical engineer, was the first Steel Industries Fellow at DBR/NRC. Mr. Berndt is a technical officer in the Fire Research Section.

Ottawa
December 1975

C. B. Crawford
Director, DBR/NRC

FIRE TESTS TO ASSESS EFFECTS OF LARGE
DUCT OPENINGS ON FIRE RESISTANCE OF STEEL-SUPPORTED
FLOOR-CEILING ASSEMBLIES

by

W. W. Stanzak and J. E. Berndt

A study of membrane ceiling fire protection has been in progress at DBR/NRC's Fire Research Section for several years. The present report describes a preliminary investigation into the effects of large duct or other service openings on the fire endurance characteristics of a membrane-protected steel joist floor assembly, a matter which has been of expressed concern to members of the Associate Committee on the National Building Code of Canada and to local authorities having jurisdiction.

A protective membrane is a continuous layer separating the member or members to be protected from fire, without coming into direct thermal contact with them. At high temperatures, therefore, it can be shown that the bulk of the heat transfer between the unexposed side of the membrane and the underside of the superstructure is due to radiation (1) and is thus dependent only on the temperature of the bounding surfaces. In "Ten Rules of Fire Endurance Rating" (2), Harmathy provides the following information relevant to membrane protection:

"Rule 3: The fire endurance of constructions containing continuous air gaps or cavities is greater than the fire endurance of similar constructions of the same weight, but containing no air gaps or cavities.

"The validity of this rule rests on the fact that by the insertion of voids, additional resistances are produced in the path of heat flow. Numerical heat flow analyses indicated that a 10 to 15 per cent increase in fire endurance can be achieved by creating an air gap at the midplane of a brick wall (2).

"Since the gross volume of constructions is also increased by the presence of voids, the air gaps and cavities have a beneficial effect on the stability as well.

"Constructions containing combustible materials along an air gap may be regarded as exceptions to this rule, because of the possible development of burning in the gap.

"Rule 4: The farther an air gap or cavity is located from the exposed surface, the more beneficial is its effect on the fire endurance.

"In the heat transfer through an air gap or cavity, radiation is the predominant mechanism. Since the heat transfer by radiation increases markedly with the average level of temperature in the void, an air gap or cavity is a very poor insulator if it is located in a region which attains high temperatures during fire exposure.

"Rule 5: The fire endurance of a construction cannot be increased by increasing the thickness of a completely enclosed air layer.

"There is evidence (2) that if the thickness of the air layer is larger than about 1/2 in., the heat transfer through the air layer depends only on the temperature of the bounding surfaces, but is practically independent of the distance between them.

"Rule 6: Layers of materials of low thermal conductivity are better utilized on that side of the construction on which fire is more likely to happen.

"The validity of this rule has been demonstrated (2). The rule may not be applicable to materials undergoing physicochemical changes accompanied by significant heat absorption or heat evolution."

This information indicates that as long as no significant gas flow is permitted into the plenum space, fire resistance of floor-ceiling assemblies should not be significantly affected by suitably shielded (against radiative heat transfer) service openings. A sponsored research project substantiates this statement (3). This research, however, is subject to the following limitations:

- a "split-frame" type assembly was used, so that the mechanical performance of the construction elements, as well as the heat transfer process, may not be completely indicative of performance in a full-scale test;

- none of the tests explored the effectiveness of protecting openings and ductwork against the effects of vertical radiation only;

i.e., the sides of ductwork were protected, adding considerably to the expense of the construction;

- the maximum size of duct opening incorporated in the tests was less than is required to achieve good mechanical efficiency of air handling in certain types of occupancy;

- one of the methods investigated involved use of a "fire-stop flap" or so-called "ceiling damper"; this device is expensive, usually field manufactured, and does not provide an effective means of stopping air and smoke flow.

The present tests, therefore, were designed to demonstrate the following:

- in the full-scale test, the presence of ductwork does not significantly affect the mechanical performance of the construction elements or the heat transfer process;

- protection of the opening and ductwork against vertical radiation is adequate; this is known as "partial protection" and is most conveniently accomplished by using the ceiling material as the radiation barrier;

- the maximum size of duct opening into the ceiling membrane need not be limited to very small areas.

In demonstrating this, it is assumed that suitable provision is made to stop air flow in the ductwork without use of a "fire-stop flap" or "ceiling damper". This is accomplished either by a fire damper where the ductwork passes through fire separations, or by a shut down of the mechanical system.

Variables in the investigation were kept to a minimum. One assembly incorporated an unbroken gypsum board membrane suspended ceiling, the other an identical ceiling except for a nominal 3- by 3-ft duct opening at ceiling level and suspended ductwork above. Details of the assemblies and their construction will be described.

DESCRIPTION OF TEST ASSEMBLIES

Figure 1 is an isometric view of assembly No. 2. The item numbers below correspond with the part numbers shown in the figure.

1. Steel joists: 16 in. deep, spaced 3 ft either side of furnace centreline (6 ft o.c.), clear span 15 ft 0 in., effective span 15 ft 4 in. The two joists in assembly No. 1 were provided with

1- by 1- by 1/8-in. angle X-bridging at mid-span and had cold-formed chords. The joists of assembly No. 2 were unbridged because the duct was located between them and had hot rolled steel chords. All joists were supported on W10X21 beams at the east and west ends of the test frame, and were attached to the beams with a tack weld about 1 in. long.

2. Steel deck: 16 Ga (0.060 in.) wiped-zinc galvanized steel, 1 1/2 in. deep, fluted, supplied in 6-ft and 3-ft 2-in. spans. The deck was plug welded to the joists at approximately 8 in. o.c. with a 5/8-in. steel washer and was simply supported on unit masonry at the perimeter of the test frame.
3. Concrete fill: placed 2 1/2 in. deep over top of the steel deck, average compressive strength 3670 psi (73 days), maximum aggregate 5/8 in., average slump 2 3/8 in.
4. Sheet steel duct: 26 Ga (0.024 in.) galvanized steel, 14 ft long by 35 1/2 in. wide and 12 in. deep, with a 4-in. riser measuring 35 1/2 in. sq. (area 8.63 ft²), duct ends closed.
5. Grill: 26 GA (0.024 in.) galvanized sheet steel, 35 1/2 in. sq., inserted into riser and attached with four sheet metal screws. The grill was provided with ten diffuser blades and a 1-in. lip around the perimeter.
6. Duct hanger straps: 1 by 1/16 in., screwed to threaded steel studs imbedded in steel deck and concrete. Four hangers were provided on each side of the duct and screwed to same with two sheet metal screws at each hanger.
7. Steel stud: standard 1 5/8-in. drywall stud, cold-formed from wiped-zinc galvanized steel approximately 0.019 in. thick, supplied in 9-ft lengths and spaced at 4 ft o.c. The studs were nested in the installation to provide a sliding joint to accommodate thermal expansion. Four lines of studs were spaced at 4 ft o.c.
8. Hanger wire: 12 Ga (0.164 in.) galvanized steel rod was welded to the steel deck and used to suspend the studs from the deck at 4 ft o.c.
9. Furring channel: standard 2 3/4 in. wide by 7/8 in. deep wiped-zinc galvanized steel approximately 0.020 in. thick, supplied in 12-ft lengths and placed at right angles to the steel studs at 2 ft o.c.
10. Tie wire: 18 Ga (0.048 in.) soft steel galvanized wire was used to single-loop tie the furring channels to the studs.

11. Gypsum board: 5/8 in. thick, paper laminated, listed by Underwriters' Laboratories of Canada (4), supplied in 4- by 8-ft sheets. Joints were treated with tape and premixed joint compound.
12. Duct protection (i.e., the radiation barrier also referred to as "partial protection"): gypsum board as in No. 11, overhanging duct by 3 in. around the centre perimeter. The protection was edge-notched where necessary to allow passage of the duct hangers.

Figure 2 shows details of the ceiling system and duct layout and Figures 3 to 7 indicate other essential details of construction and instrumentation. Figures 19 to 28 are photographs relevant to the investigation.

Specimen No. 1 was identical to specimen No. 2 except that the ductwork and ceiling penetration were absent. It should also be noted that in assembly No. 1 the small ribs of the steel deck were turned upward; the orientation was reversed for assembly No. 2. All construction was carried out by members of the staff of DBR/NRC and the ductwork was manufactured in NRC's Plant Engineering Division. The workmanship was good and generally in accordance with normal commercial practice.

TEST METHOD

The specimens were subjected to fire test in accordance with the provisions of ASTM A119-71 (4) with the following exceptions in procedure:

- assembly No. 2 was not loaded in order to minimize any chance of premature ceiling failure;
- because unexposed surface temperatures were not of prime concern, they were measured at only five points on assembly No. 1;
- moisture content of the concrete topping, approximately 10 months old, was not measured.

Gas flow into the furnace was controlled automatically so as to follow closely the temperature-time curve prescribed by the standard. Furnace temperature was measured by nine symmetrically distributed thermocouples enclosed in 13/16 in. o.d. inconel tubes having a wall thickness of 0.035 in. and equipped with a carbon steel cap at the tip. The hot junction of the thermocouples was placed 12 in. from the exposed face of the specimen. Both the individual temperatures at the nine points and the average of the nine were recorded during the test.

The temperature of the unexposed surface of specimen No. 1 was measured by five thermocouples located at the centre and quarter points

of the assembly. On specimen No. 2, temperatures in the plenum and on the unexposed surface were measured by thermocouples located as shown in Figures 6 and 7. All unexposed surface thermocouples were covered with standard asbestos pads 6 in. square and 0.4 in. thick.

Joist temperatures were measured at 24 points at the centre and quarter spans. Location of the thermocouples on the cross-section is shown in Figure 5.

During the test, a live load of 125 lb/sq ft was applied to assembly No. 1; assembly No.2 was not loaded.

Numerous thermocouples were distributed throughout the plenum space to measure temperatures of the unexposed ceiling face, air, duct-work and underside of the steel deck, etc.

OBSERVATIONS

Significant observations on the exposed surface were recorded during the fire tests; they were fairly similar for both tests.

At about 1/2 min, the exposed surface had already darkened and was beginning to flame; and after about 2 min the flames were diminishing. By 6 min the joint compound and tape were peeling, and by about 15 min the joints were completely bare. They were opening by this time owing to shrinkage of the gypsum board. Both ceilings remained relatively intact for about 2 hr: in assembly No. 1 a panel dropped at 2 hr 24 min; in assembly No. 2 a large portion of a panel dropped at 119 min. Following this, other panels fell successively for about 10 min, until the tests were terminated.

The unexposed surfaces of the test specimens developed numerous cracks ranging from hairline to 1/4 in.

RESULTS

Temperatures that developed in the furnace and tested assemblies are illustrated in Figures 8 to 18. The figures are labelled so as to be self-explanatory.

Imminent structural failure of the assemblies was judged by use of critical temperature criteria as described in ASTM E119. Because the joists are spaced at more than 4 ft o.c., beam criteria apply and the critical temperatures are an average of 1100°F at any cross-section, and 1300°F at any individual point. According to these criteria, the fire resistance of the unrestrained assemblies was 2 hr, with failure of

assembly No. 1 at 145 min and failure of assembly No. 2 imminent at 132 min.

COMMENTS

It is seen from Figures 10 and 11 that temperatures of the structural steel in the assembly incorporating the duct opening (assembly No. 2) were consistently about 100 F deg higher than for the other specimen, as were other plenum temperatures. On the other hand, temperatures above the duct protection and on the unexposed surface above the duct were somewhat lower. This indicates that inclusion of a partially protected duct system poses only a minor threat to the structural support system and does not significantly affect the fire performance of the entire assembly.

CONCLUSIONS

1. Provided that the air flow is stopped, partial protection of duct assemblies against vertical radiation provides a satisfactory method for retaining the fire resistive qualities of membrane-protected floor and roof systems with ceiling penetrations.
2. The size of opening at the ceiling level need not be limited to very small areas provided suitable protection is located above the duct system. The present tests have demonstrated the validity of this principle for a single opening having an area of 8.63 ft², or a unit opening area of 4.8 ft²/100 ft² of ceiling area.
3. The fire resistance rating according to ASTM E119-71 unrestrained beam temperature criteria was 2 hr for both assemblies tested.
4. Figures 10 and 11 indicate that the partially protected ductwork decreased the structural fire resistance of assembly No. 2 by about 12 min as compared with the unbroken ceiling in assembly No. 1. This is a 10 per cent reduction.
5. A "fire-stop flap" or "ceiling damper" is redundant when other means of stopping air flow in mechanical systems are provided, and when the duct opening is appropriately shielded to block vertical radiative heat transfer.

ACKNOWLEDGEMENT

This project was part of a cooperative agreement between the National Research Council of Canada and the Canadian Steel Industries Construction Council: the Steel Industries Fellowship Program.

REFERENCES

1. Harmathy, T.Z., A Treatise on Theoretical Fire Endurance Rating, ASTM Special Technical Publication No. 301, 1961.
2. Harmathy, T.Z., Ten Rules of Fire Endurance Rating, Building Research Note No. 46, Division of Building Research, National Research Council, Ottawa, 1964.
3. American Iron and Steel Institute, Research Report: Alternate Methods of Fire Protection for Ceiling Outlets of Galvanized Steel Ducts, 1972.
4. Underwriters' Laboratories of Canada, List of Equipment and Materials, Building Construction, Vol. II, 1972.

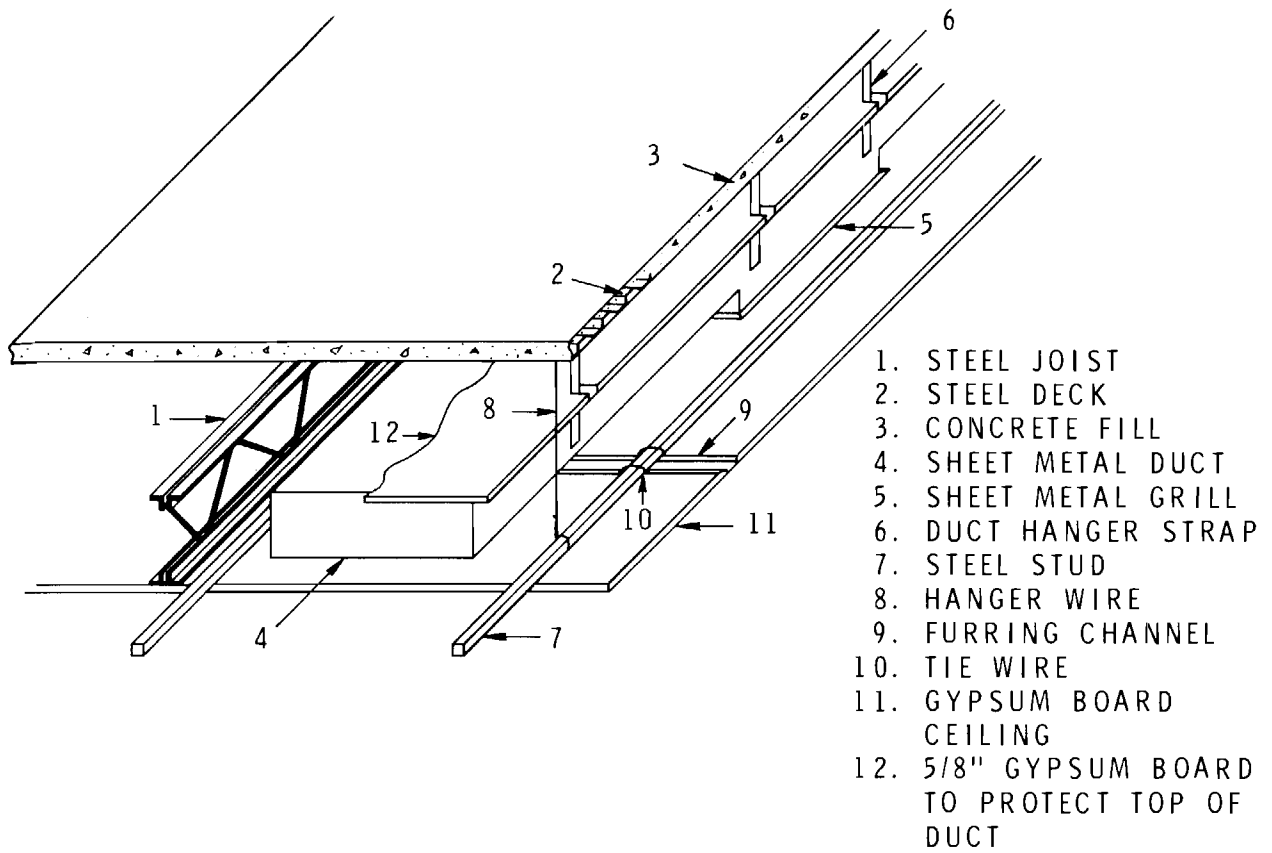

FIGURE 1
 CONSTRUCTION DETAILS

- STUD HANGERS
- DUCT HANGER STRAPS

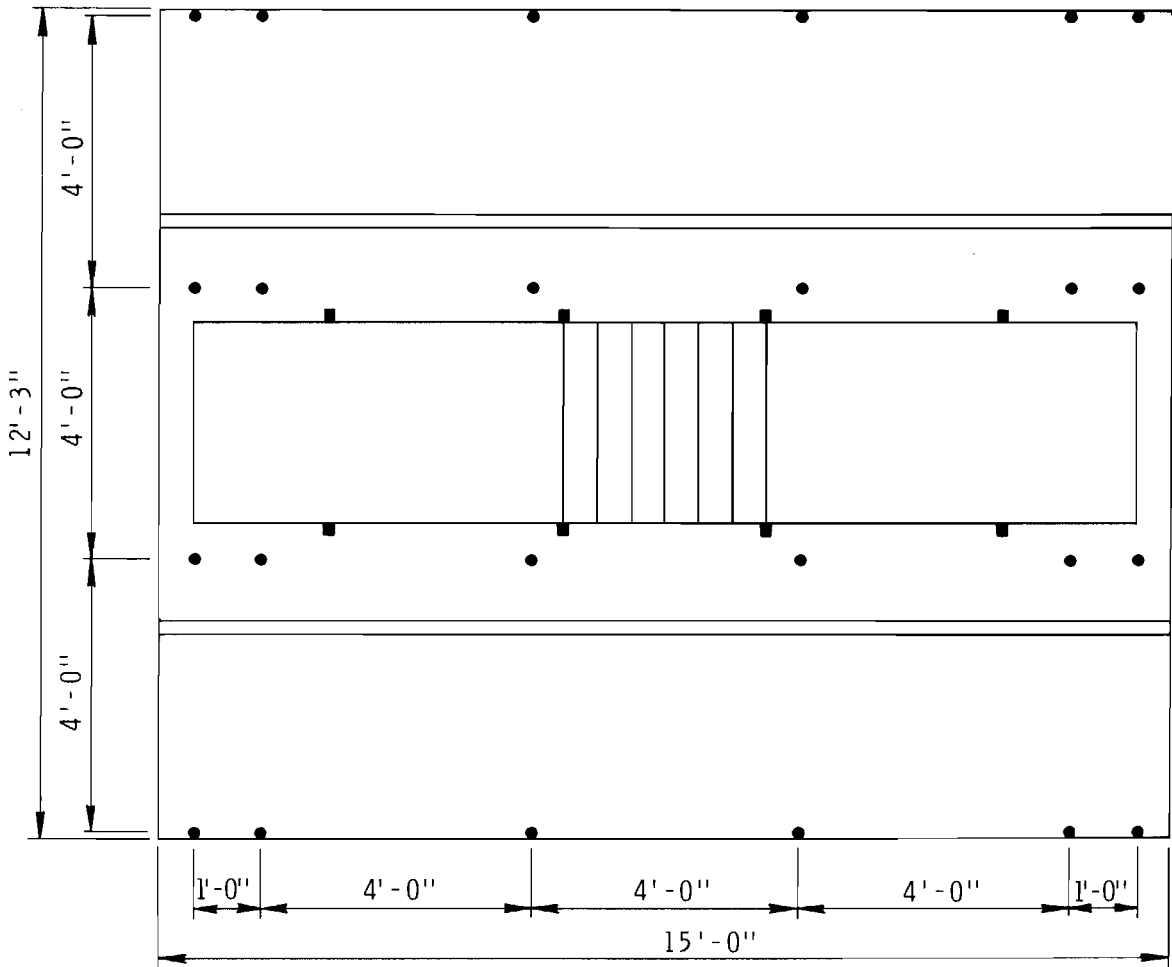

FIGURE 2
REFLECTED VIEW OF CEILING SHOWING POSITIONS OF HANGERS

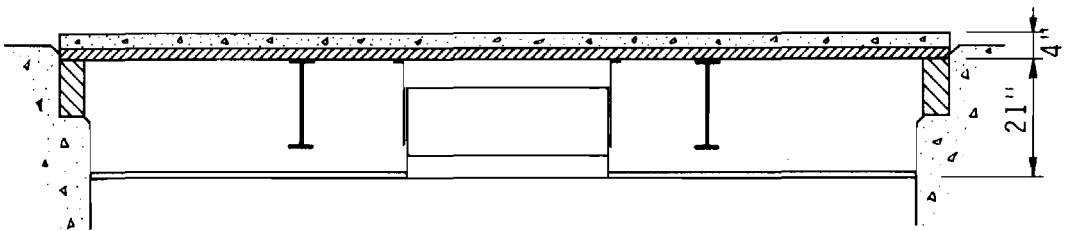
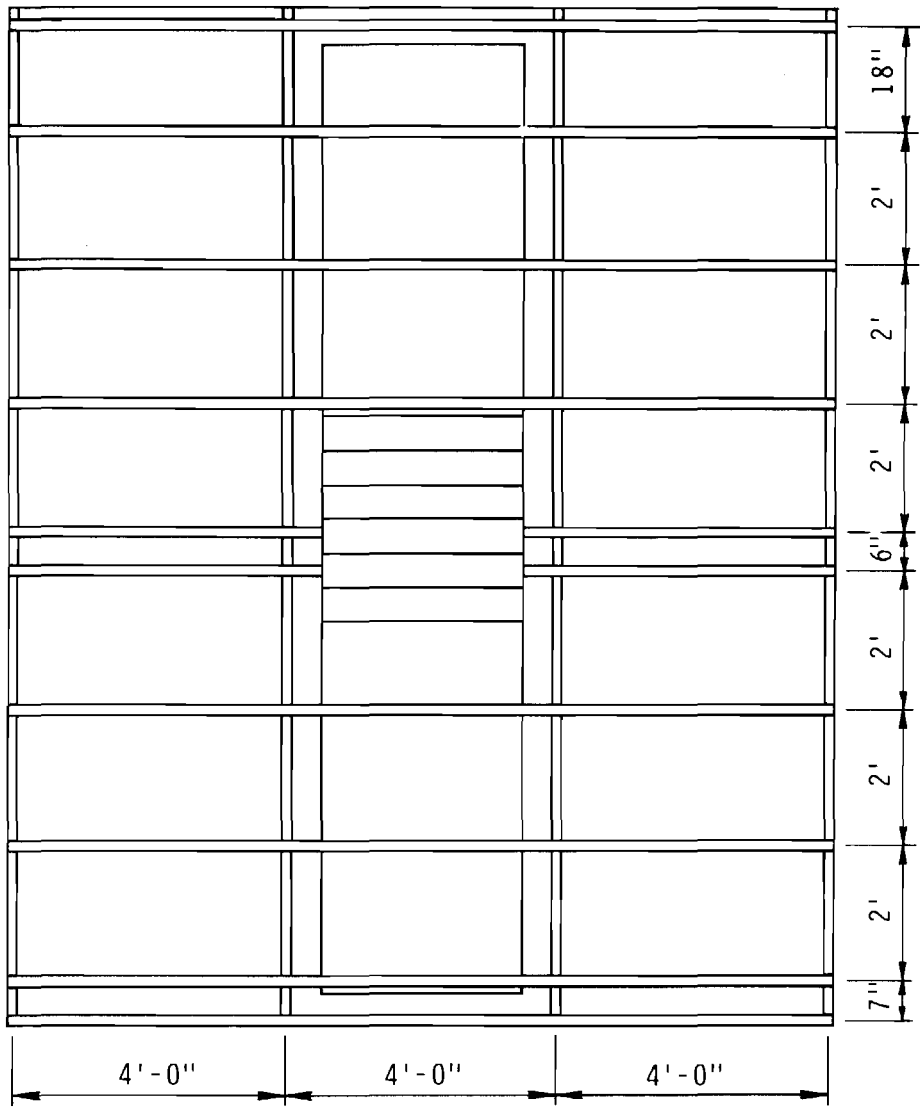

FIGURE 3
 LOCATION OF FURRING STRIPS

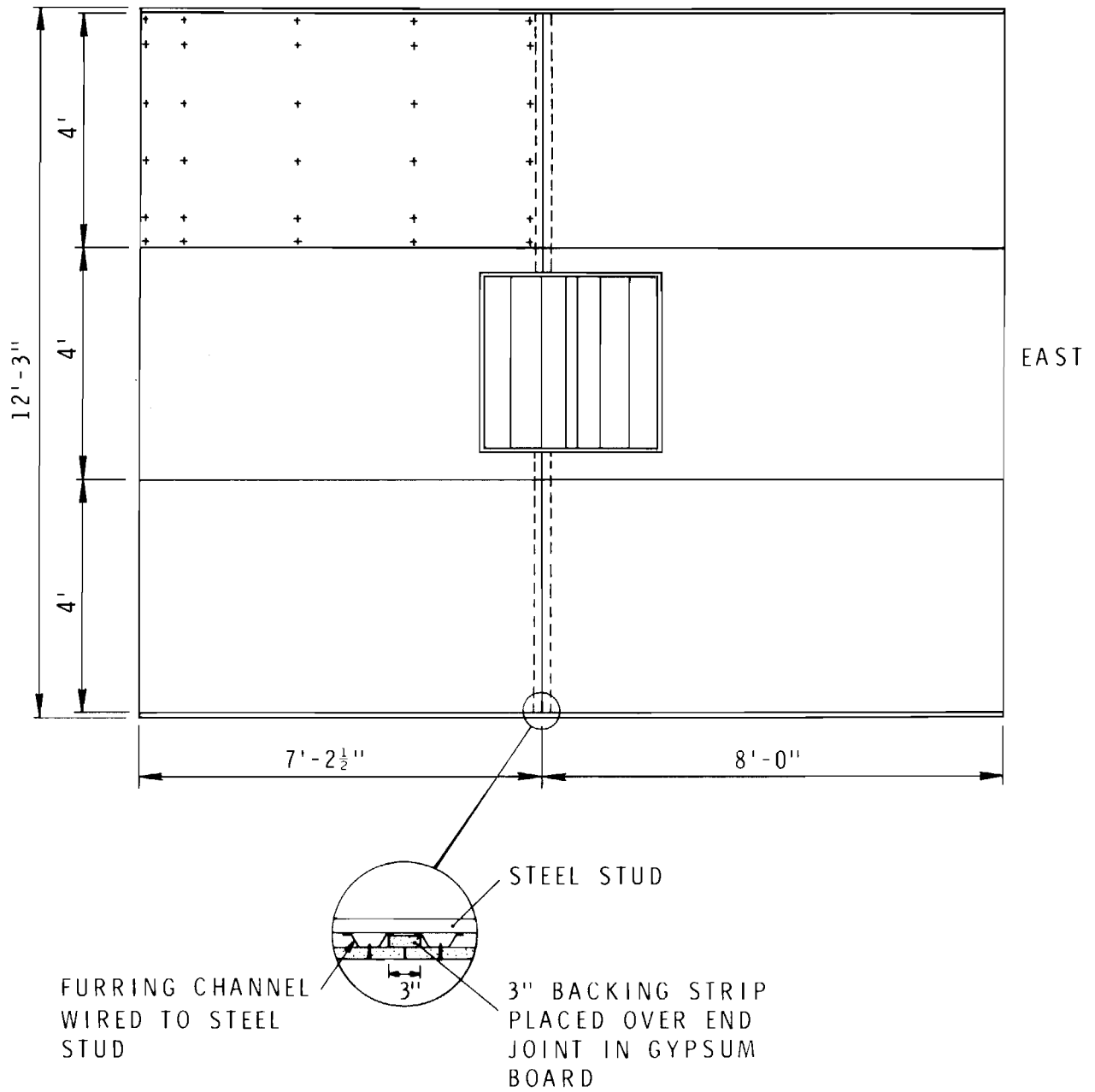
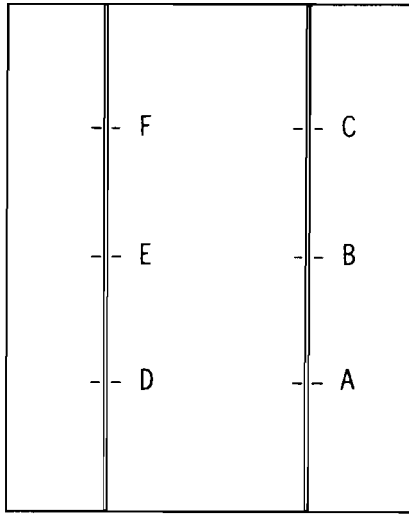
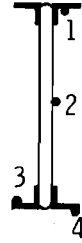

FIGURE 4

REFLECTED VIEW OF CEILING SHOWING GYPSUM BOARD LAYOUT AND SCREW LOCATIONS



EAST



	1	2	3	4
A	1	2	3	4
B	5	6	7	8
C	9	10	11	12
D	13	14	15	16
E	17	18	19	20
F	21	22	23	24

FIGURE 5
 LOCATION AND NUMBERING OF THERMOCOUPLES
 ON STEEL JOISTS

- THERMOCOUPLE ON DUCT
- THERMOCOUPLE ON TOP OF GYPSUM BOARD

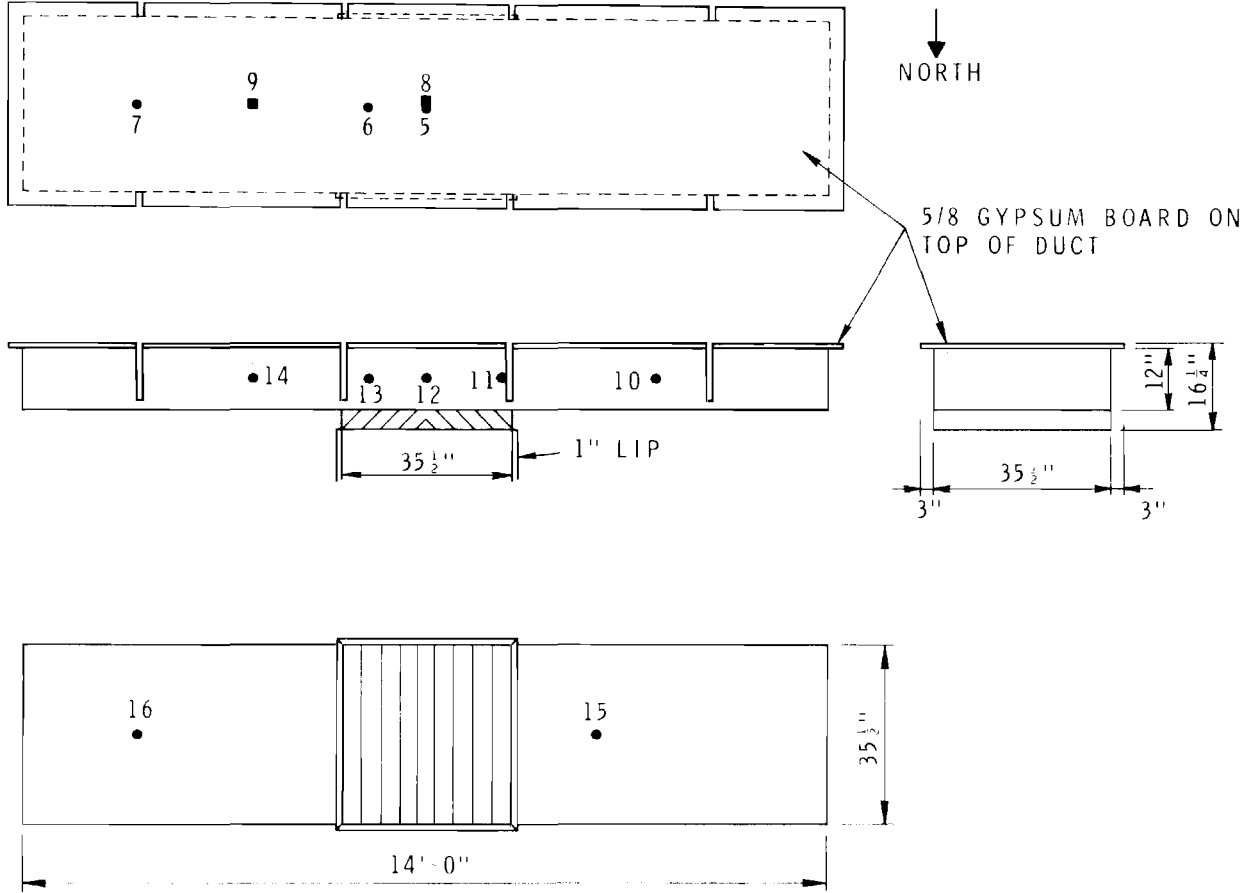

FIGURE 6
 DETAIL OF DUCT AND LOCATION OF THERMOCOUPLES

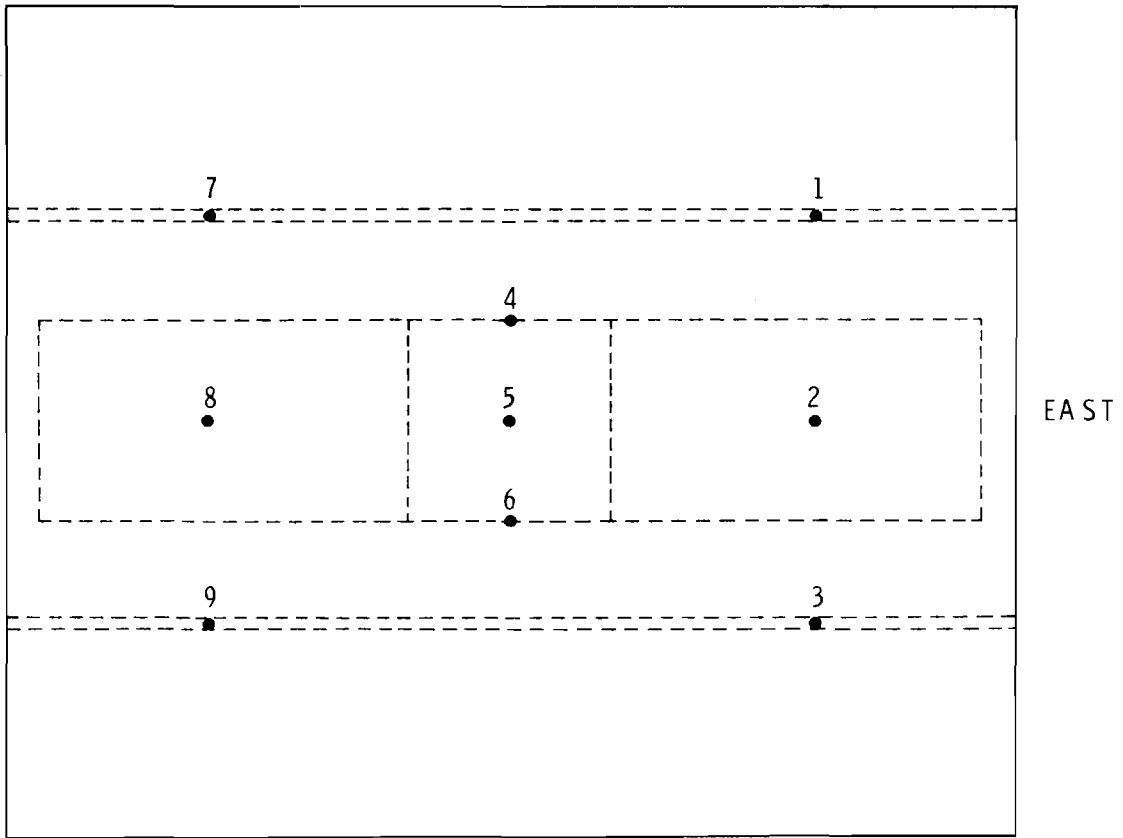

FIGURE 7
LOCATION OF THERMOCOUPLES ON UNEXPOSED SURFACE

BR 5288 - 7

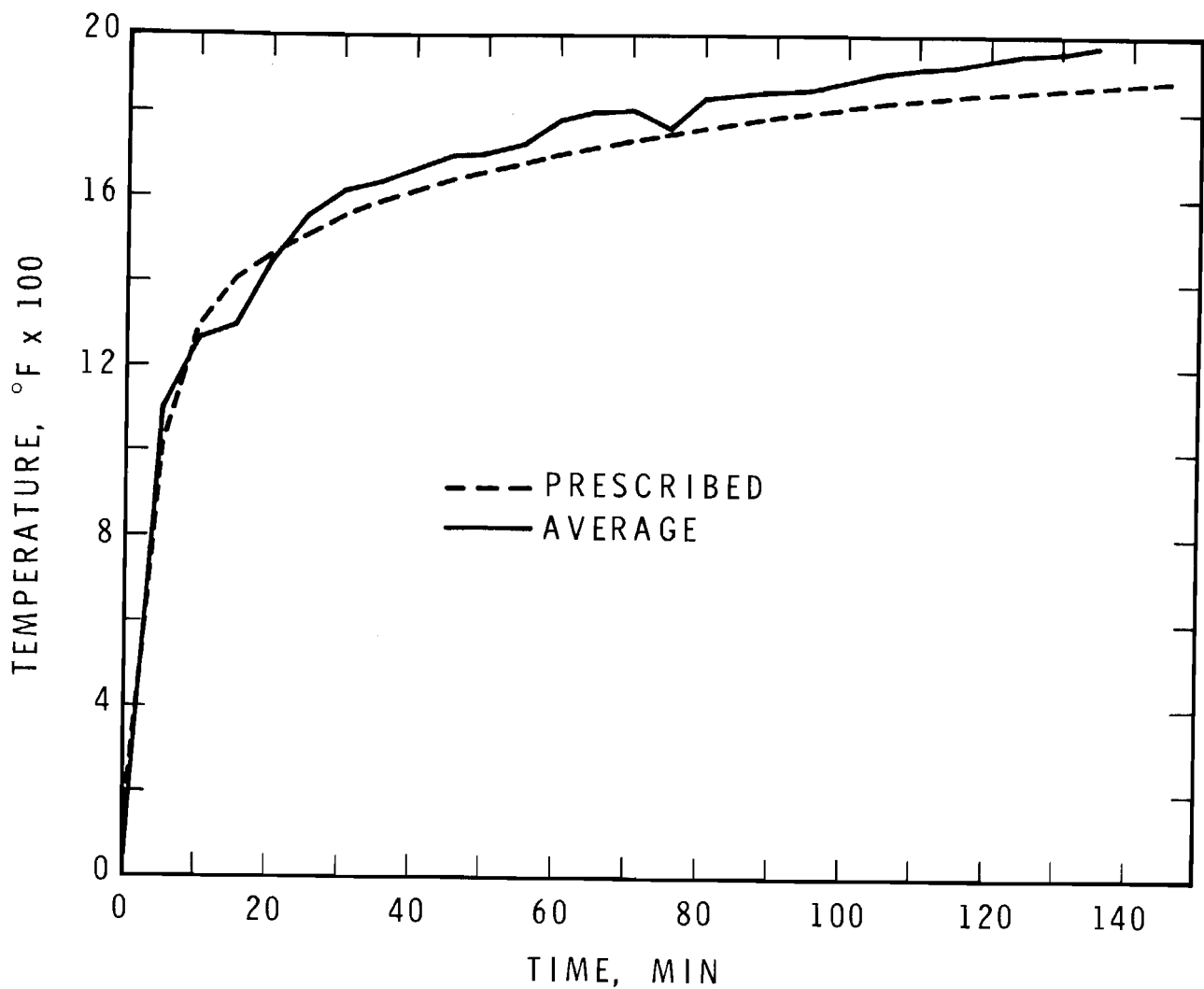

FIGURE 8
FURNACE TEMPERATURE, TEST NO. 1

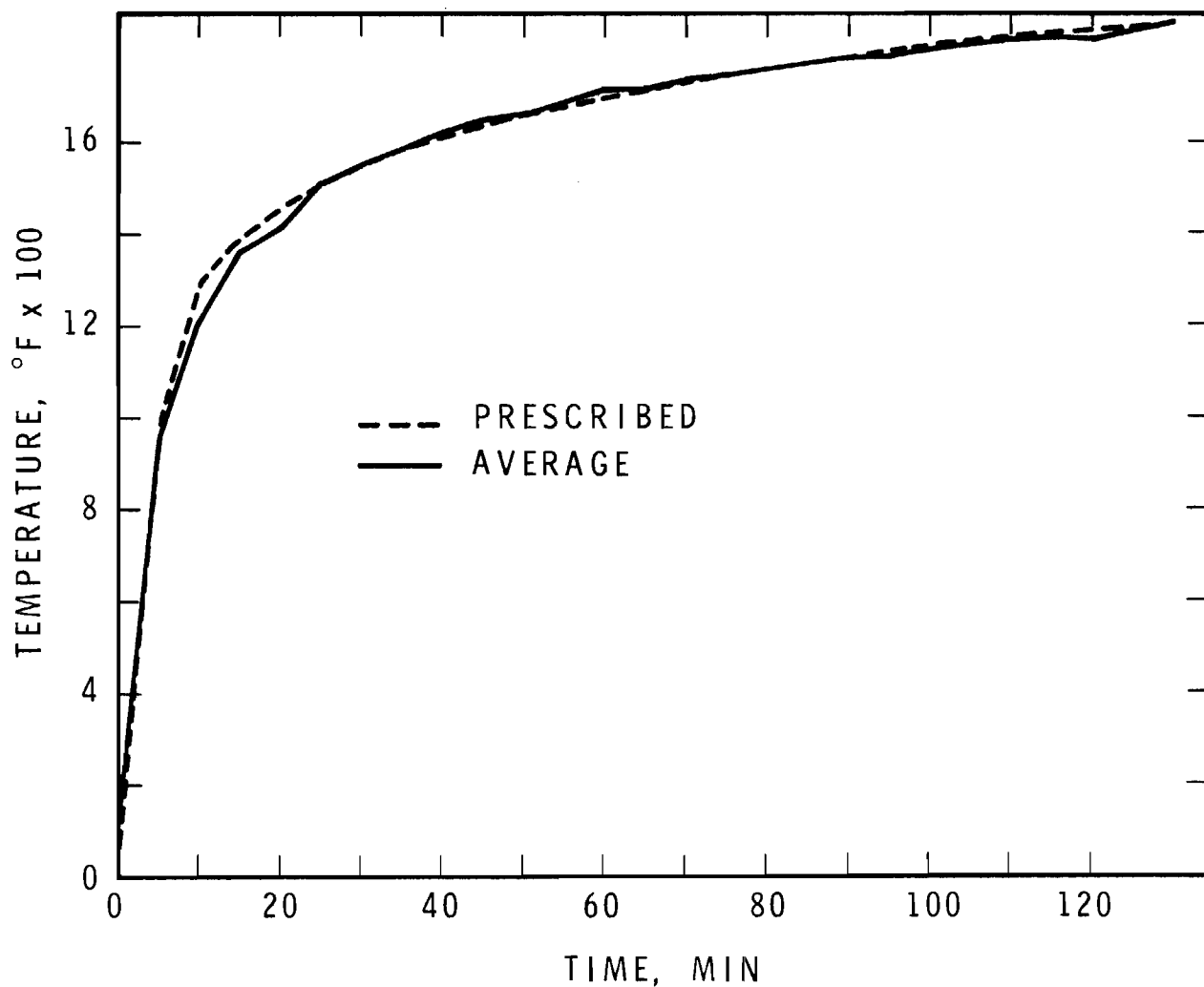

FIGURE 9
FURNACE TEMPERATURE, TEST NO. 2

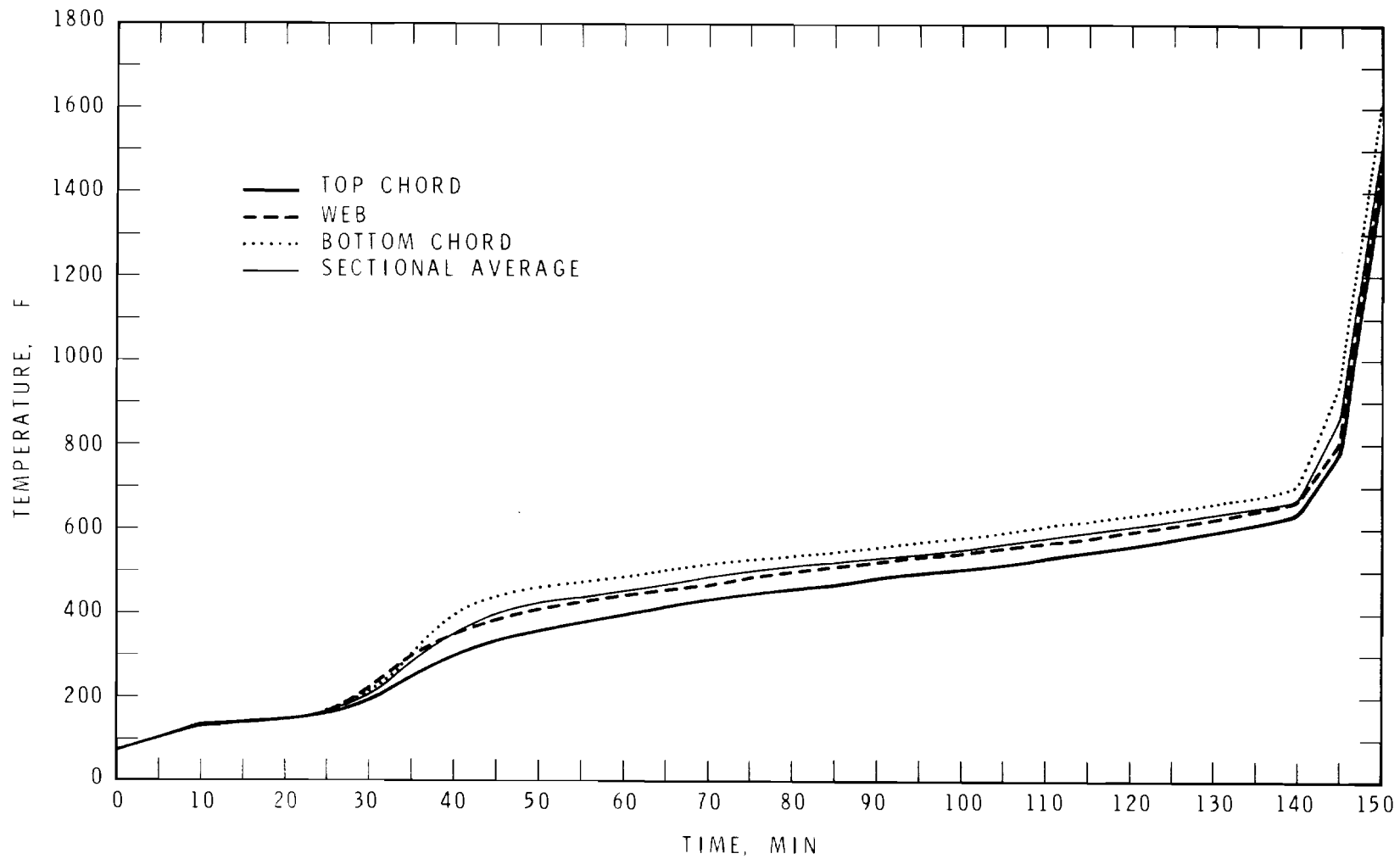

FIGURE 10
 TEMPERATURE OF STEEL JOISTS, TEST NO. 1 (NO DUCT)

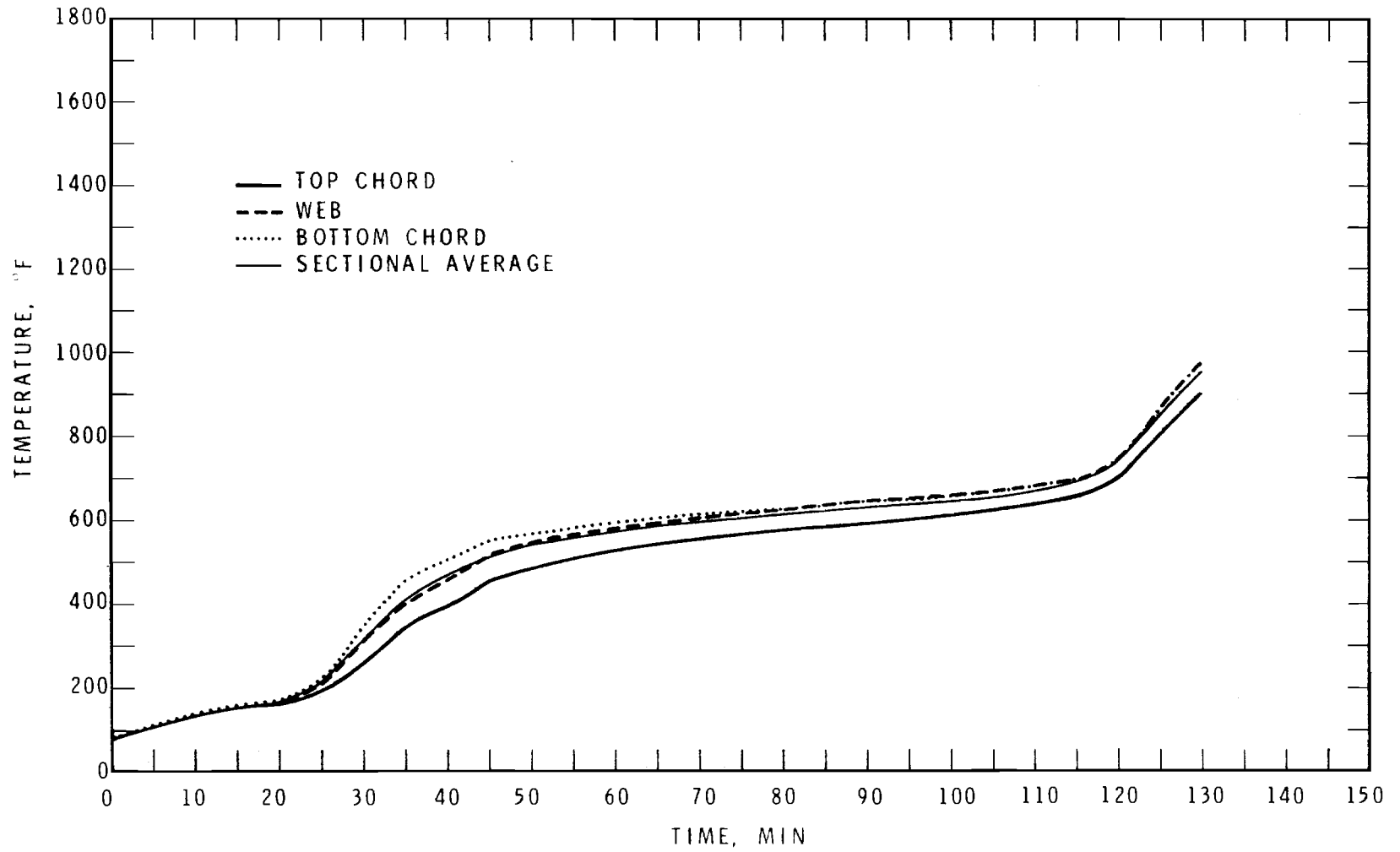

FIGURE 11
 TEMPERATURE OF STEEL JOISTS, TEST NO. 2 (WITH DUCT)

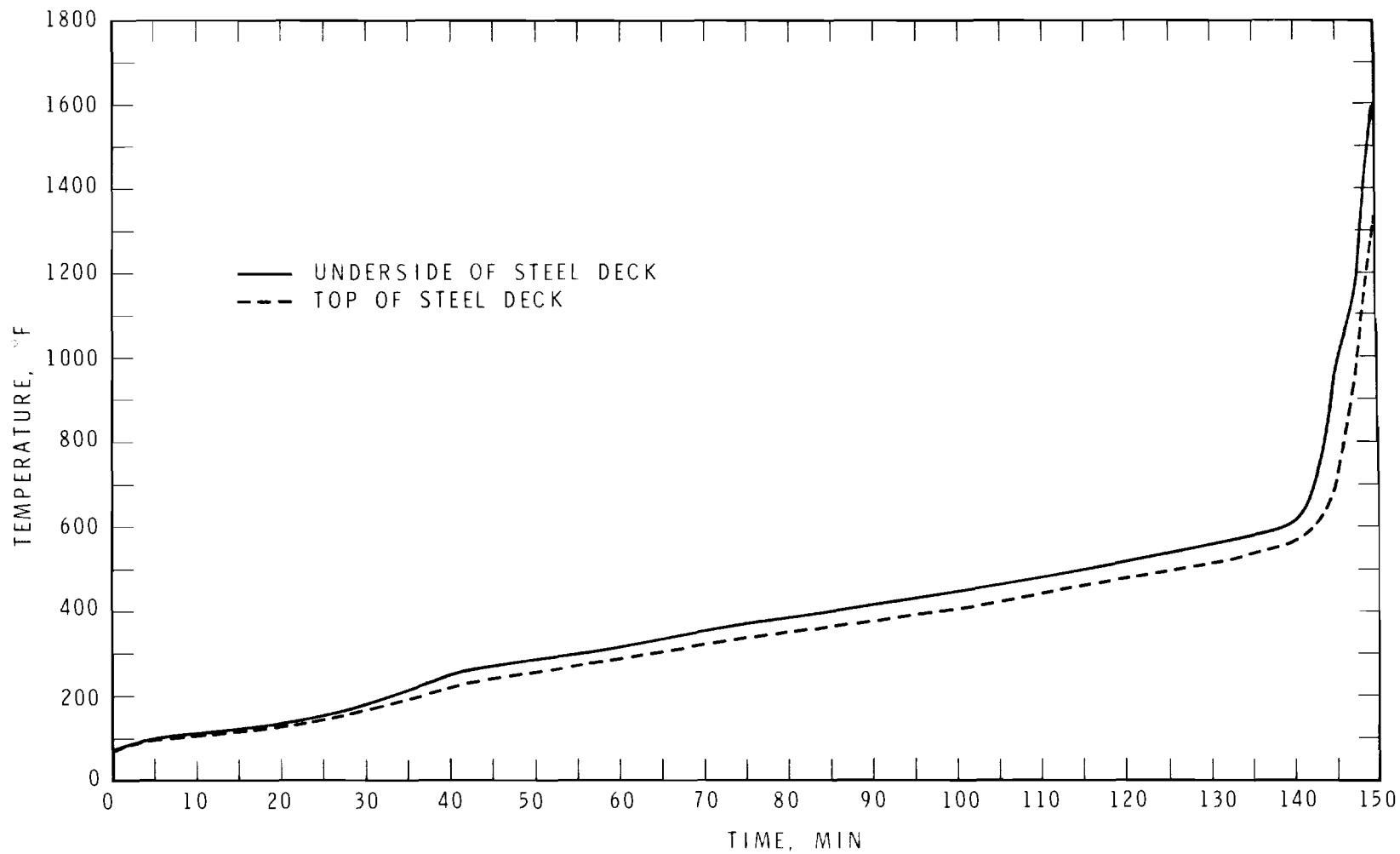

FIGURE 12
TEMPERATURES OF STEEL DECK, TEST NO. 1

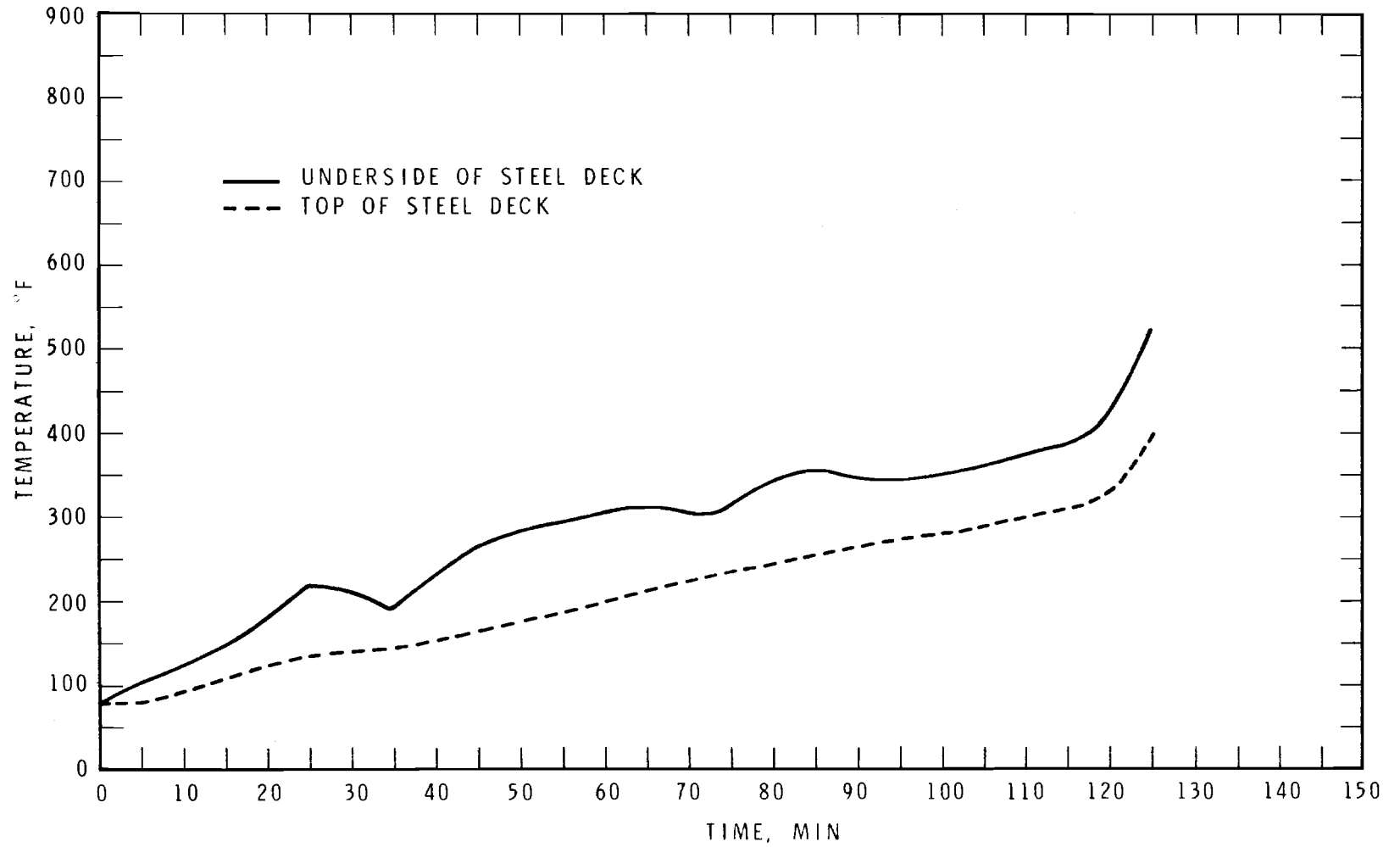

FIGURE 13
TEMPERATURES OF STEEL DECK, TEST NO. 2

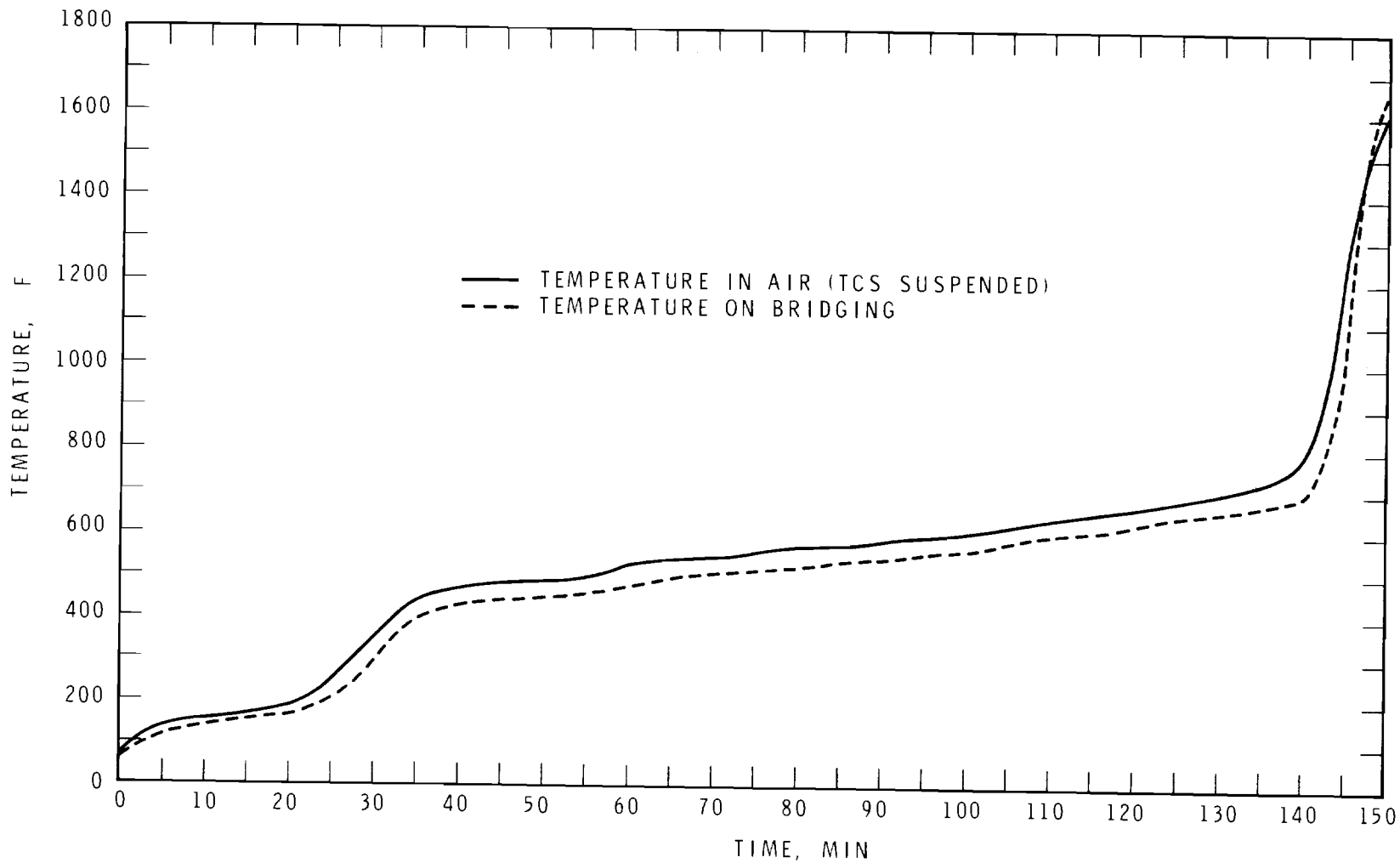

FIGURE 14
PLENUM TEMPERATURES, TEST NO. 1

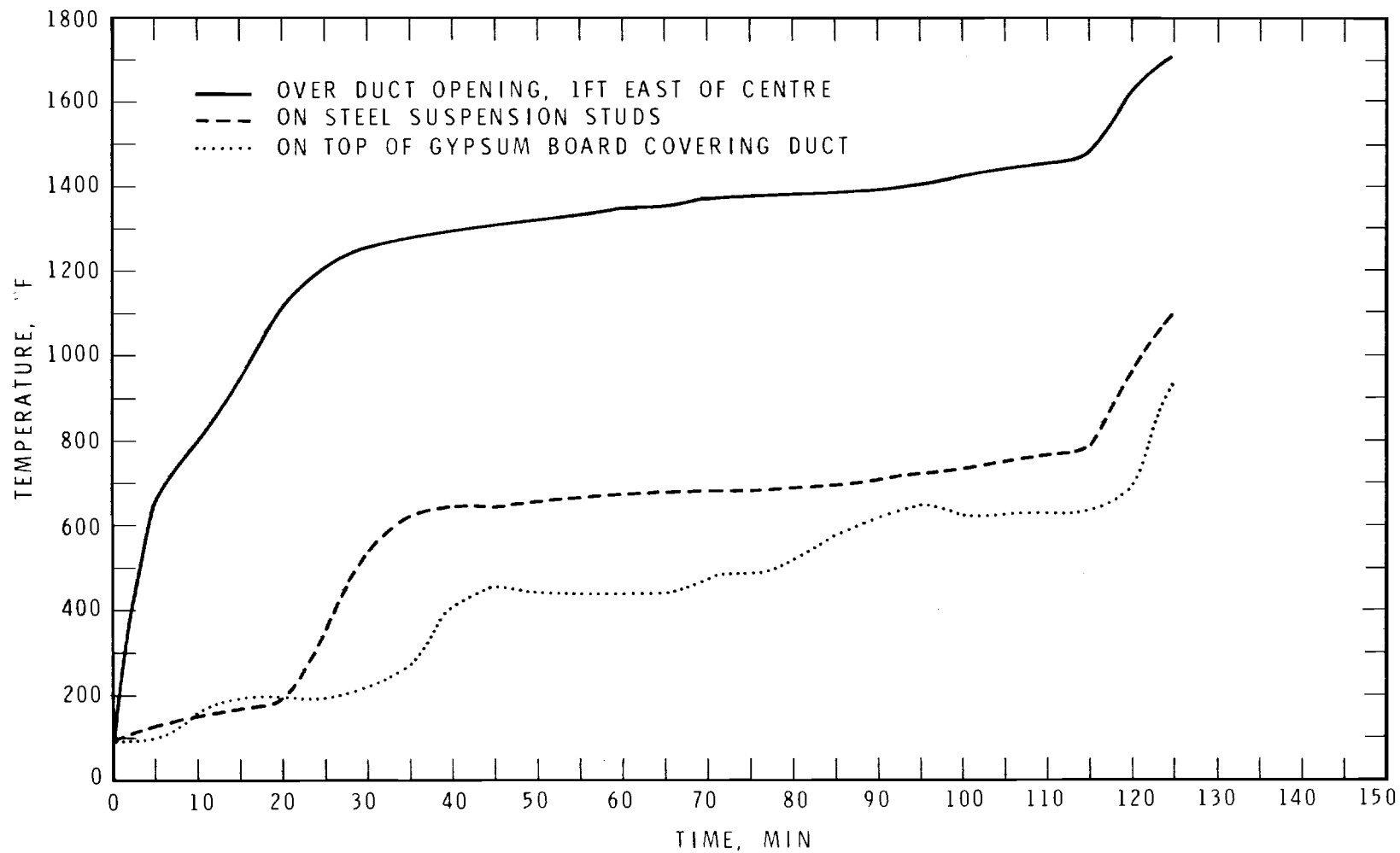

FIGURE 15
PLENUM AND DUCT TEMPERATURES, TEST NO. 2

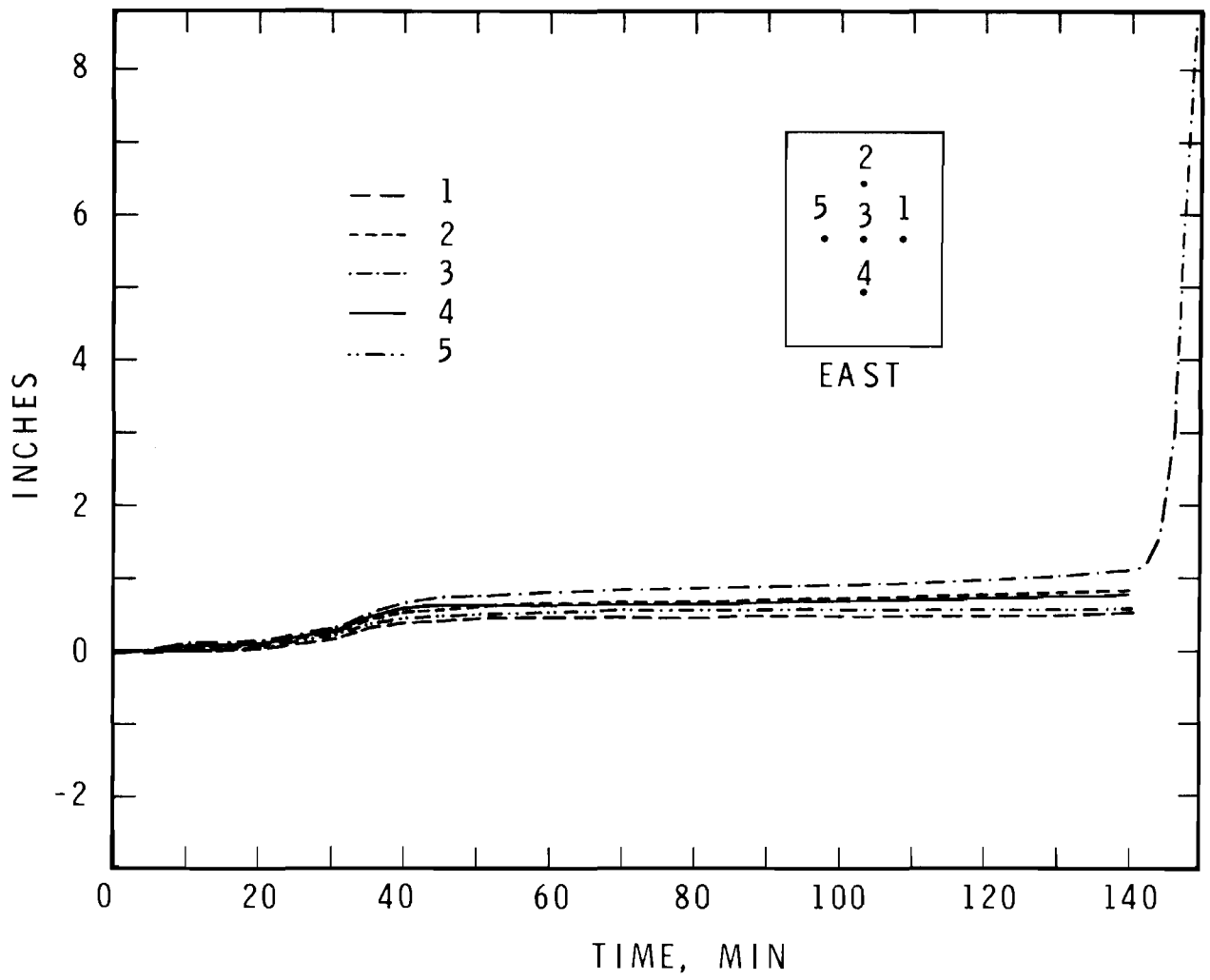

FIGURE 16
DEFLECTIONS, TEST NO. 1

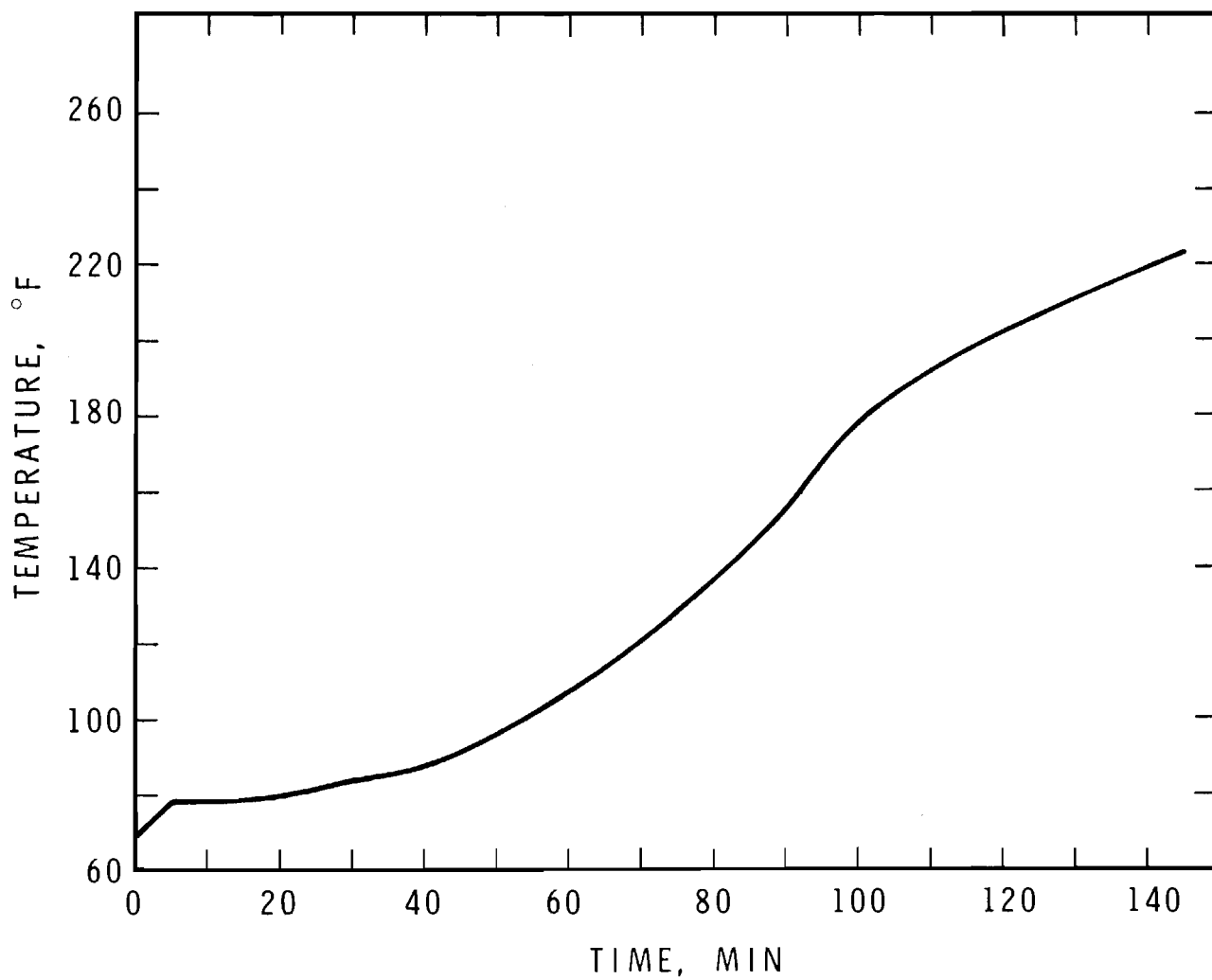

FIGURE 17

AVERAGE UNEXPOSED SURFACE TEMPERATURE, TEST NO. 1

BR 5288-17

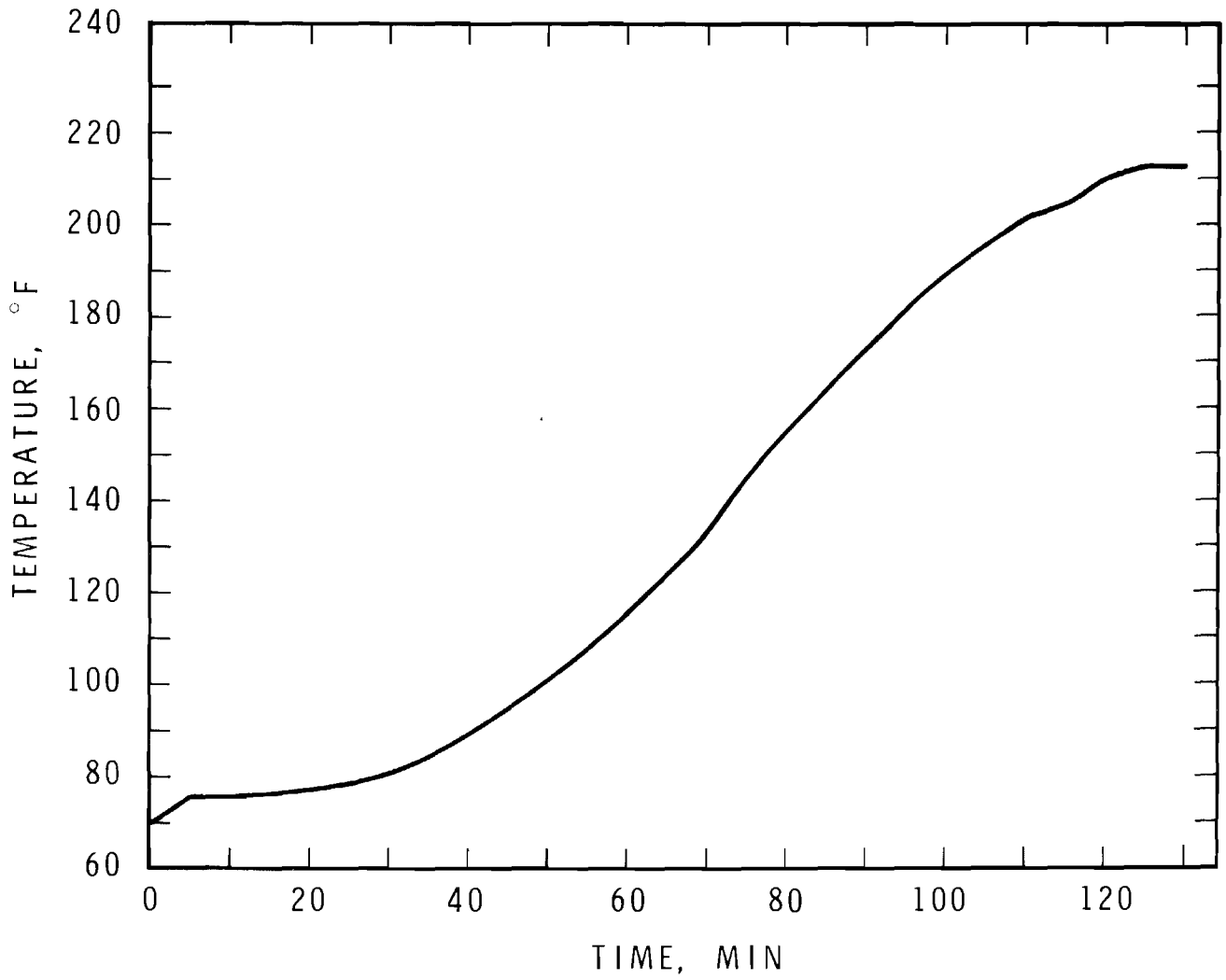

FIGURE 18

AVERAGE UNEXPOSED SURFACE TEMPERATURE, TEST NO. 2

BR 5288-18

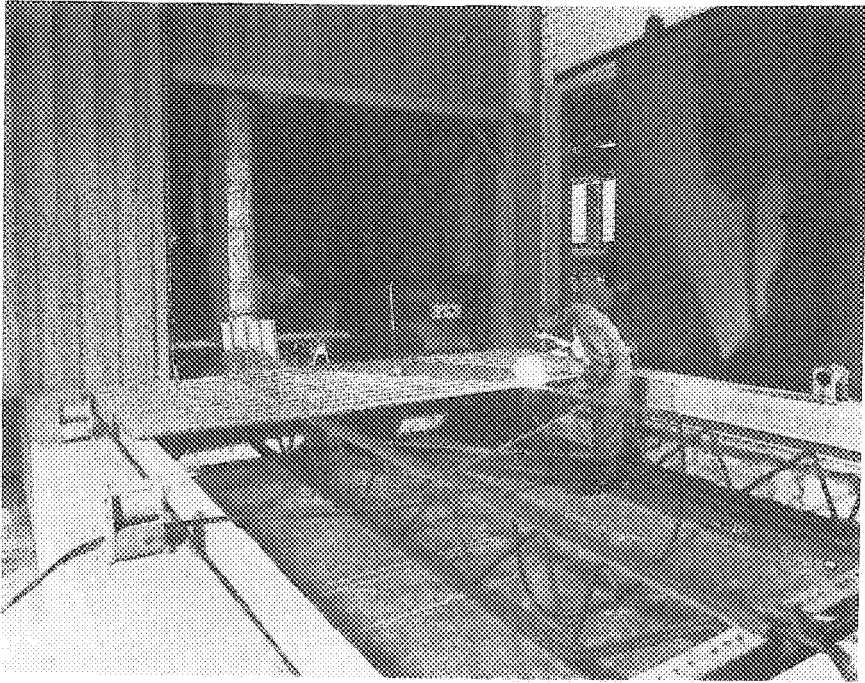

FIGURE 19 DECK INSTALLATION

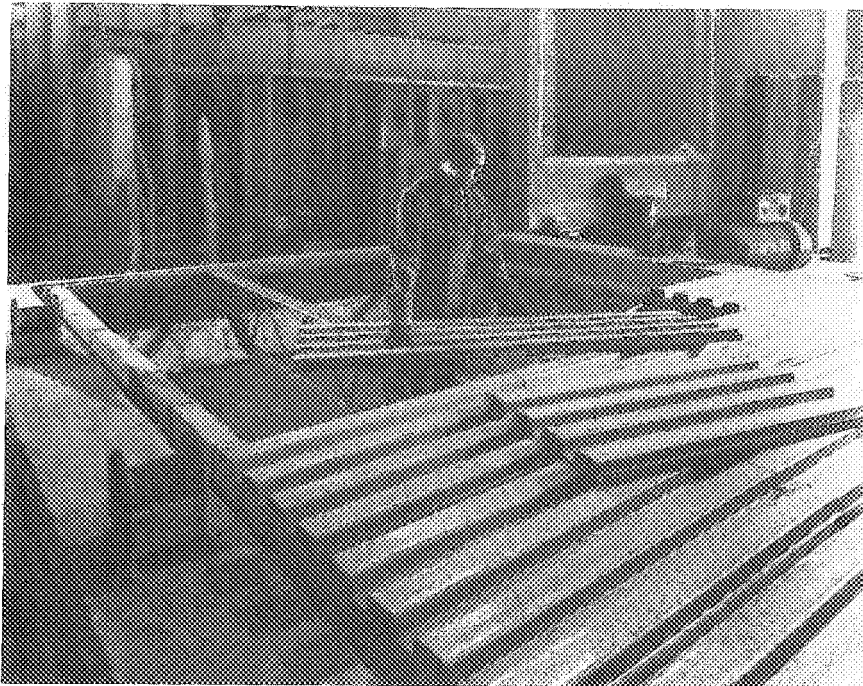

FIGURE 20 DECK INSTALLATION

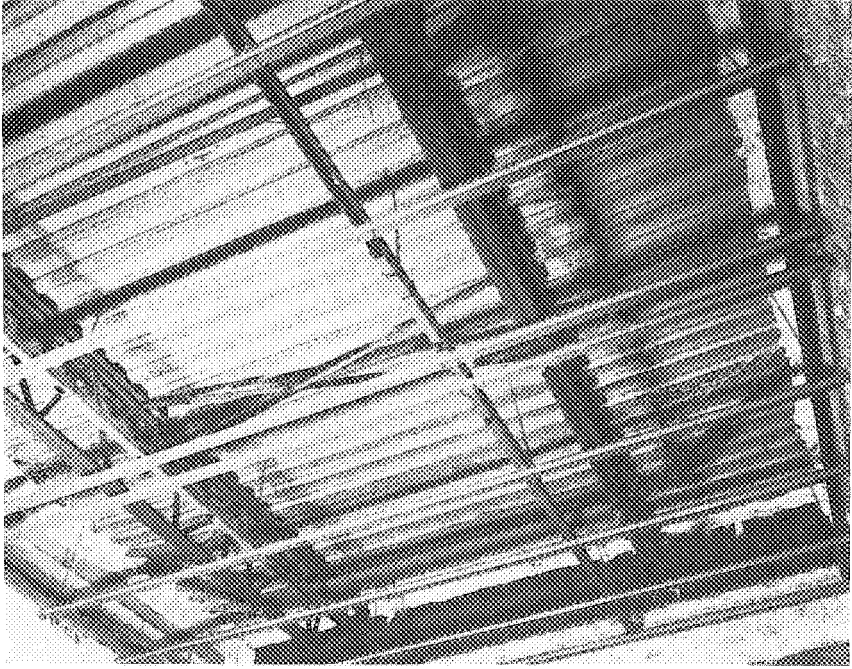

FIGURE 21 SUSPENSION AND FURRING

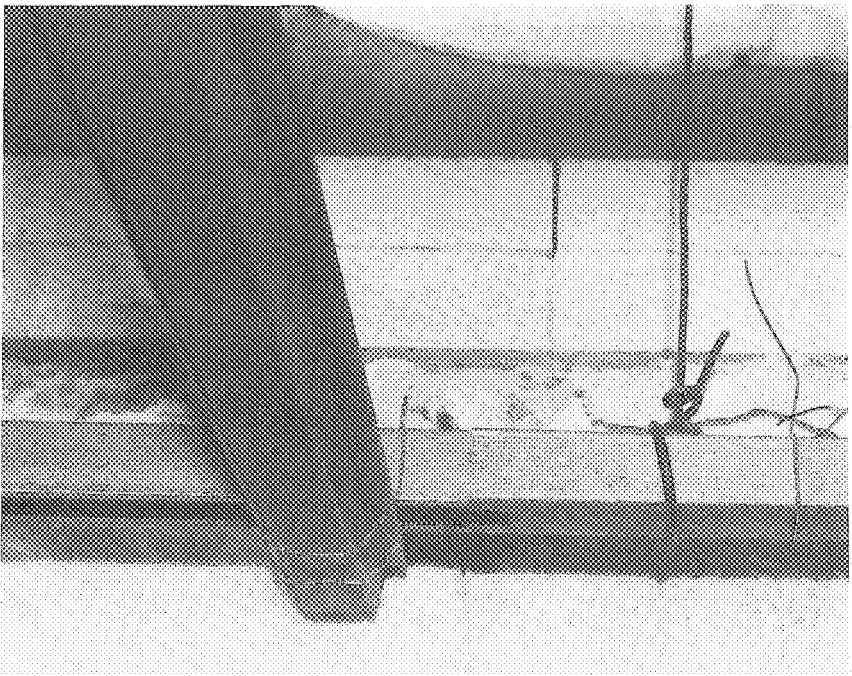

FIGURE 22 CLOSE-UP OF SUSPENSION AND FURRING



FIGURE 23 SUSPENSION AND DUCTWORK (ASSEMBLY NO. 2)

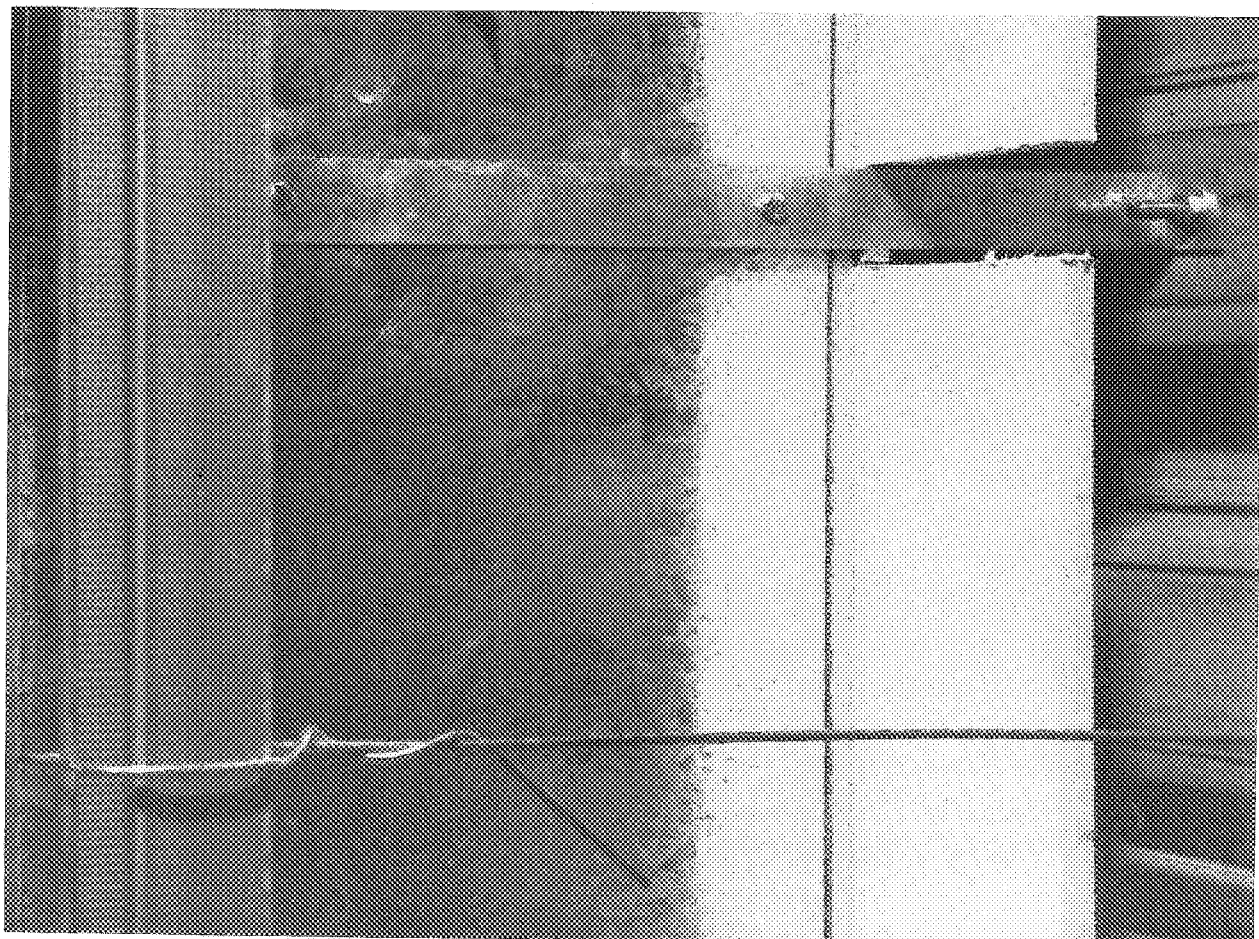

FIGURE 24 DUCT STRAP HANGER (ASSEMBLY NO. 2)

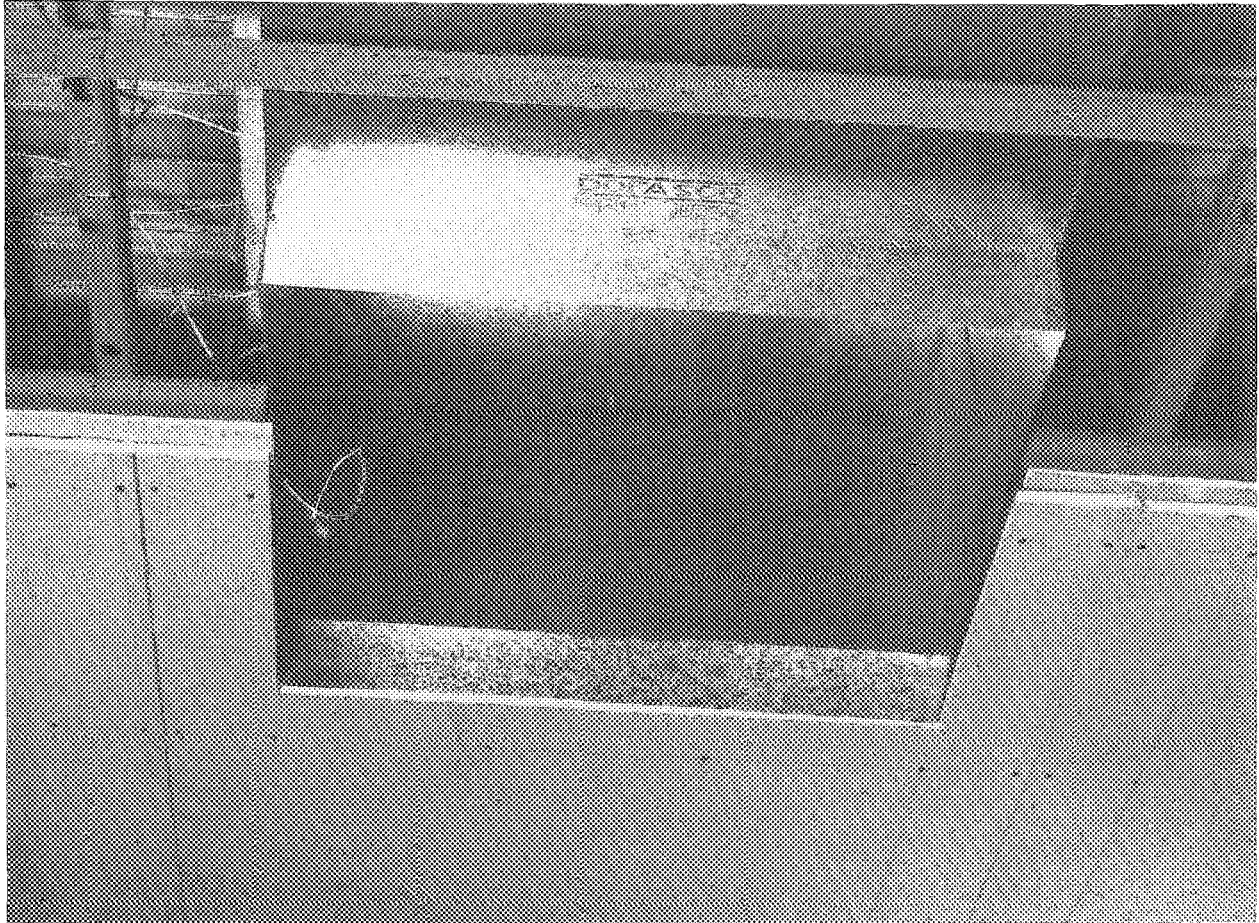

FIGURE 25 APPLICATION OF GYPSUM BOARD (ASSEMBLY NO. 2)

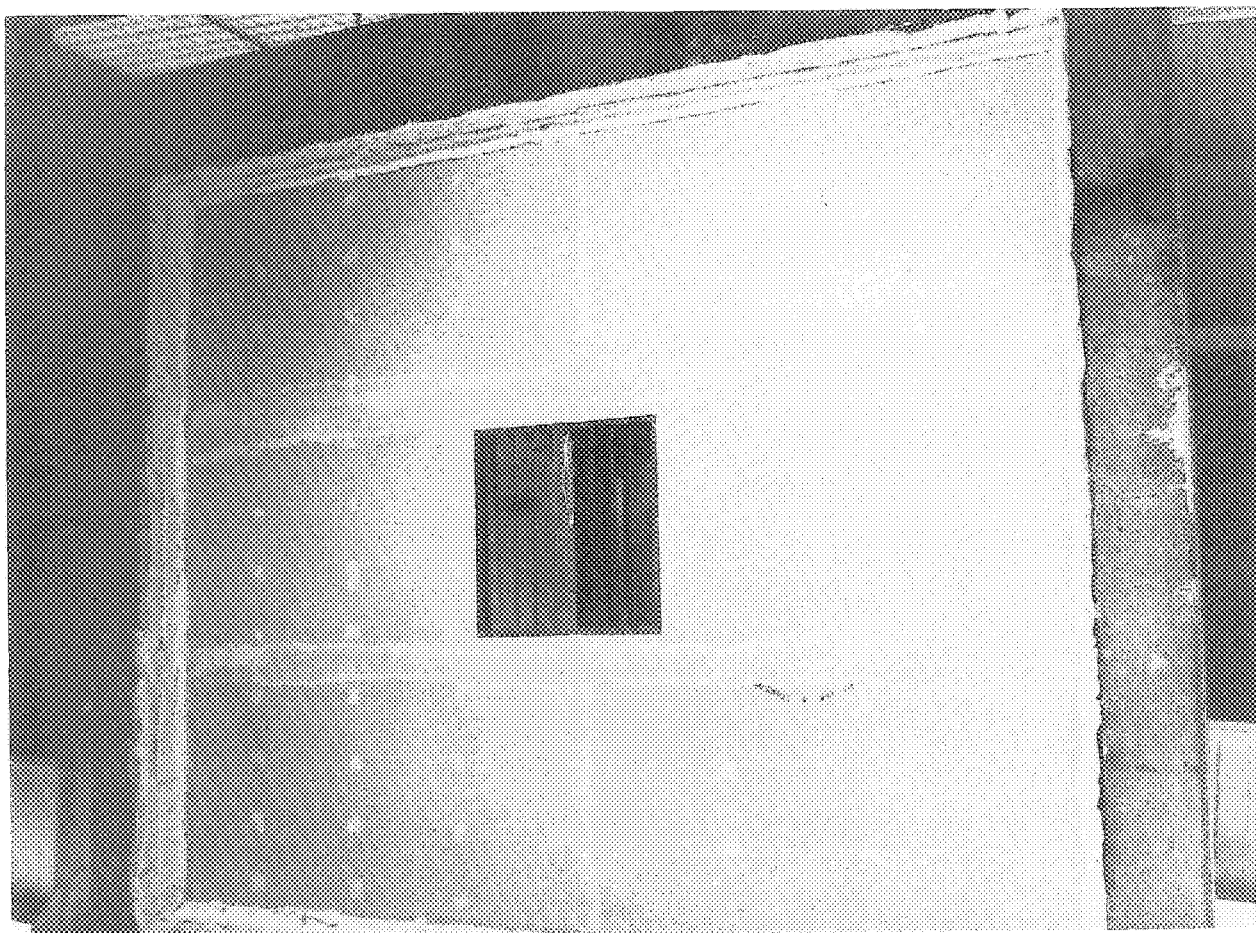

FIGURE 26 COMPLETED CEILING (ASSEMBLY NO. 2)

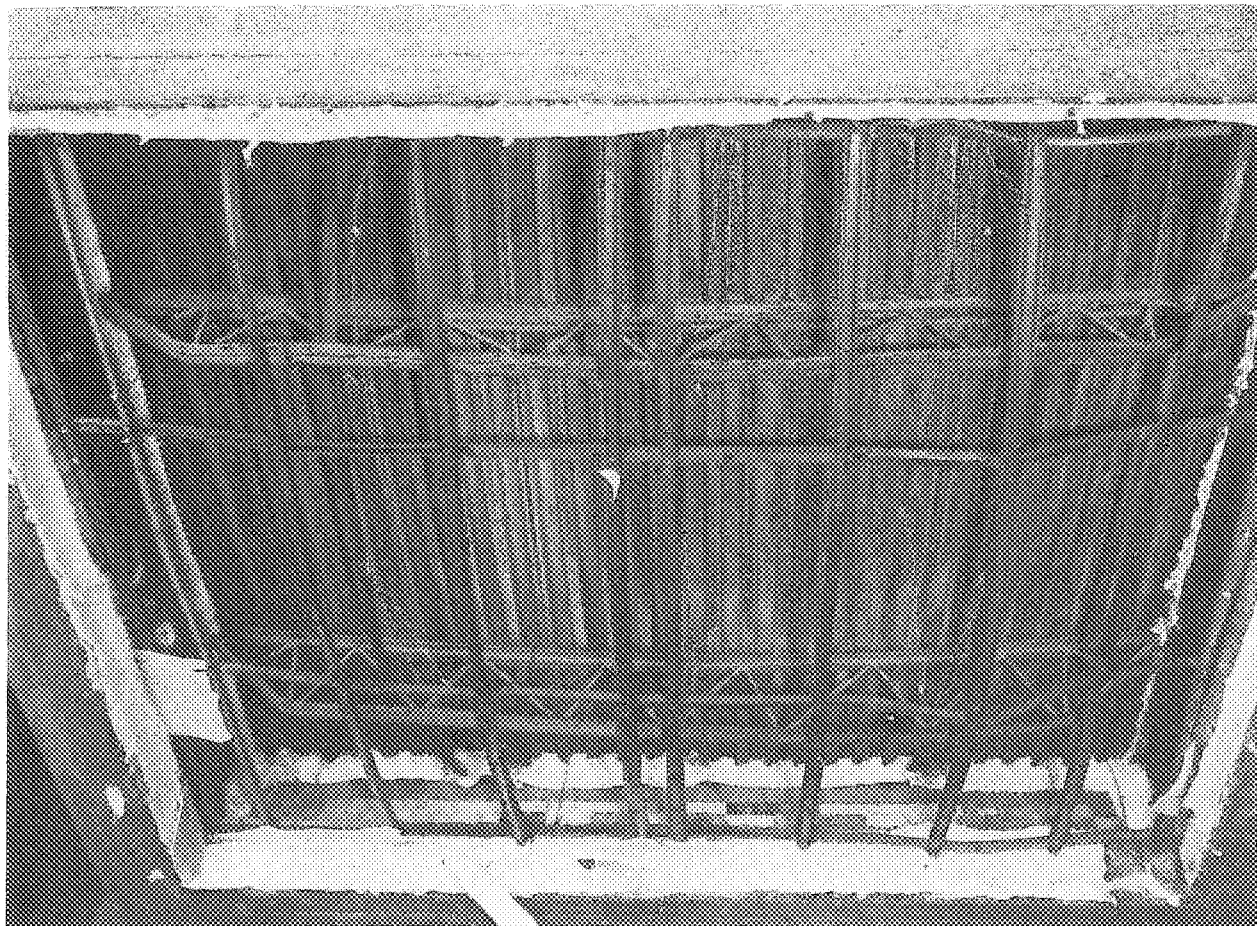

FIGURE 27 ASSEMBLY NO. 1 AFTER FIRE TEST

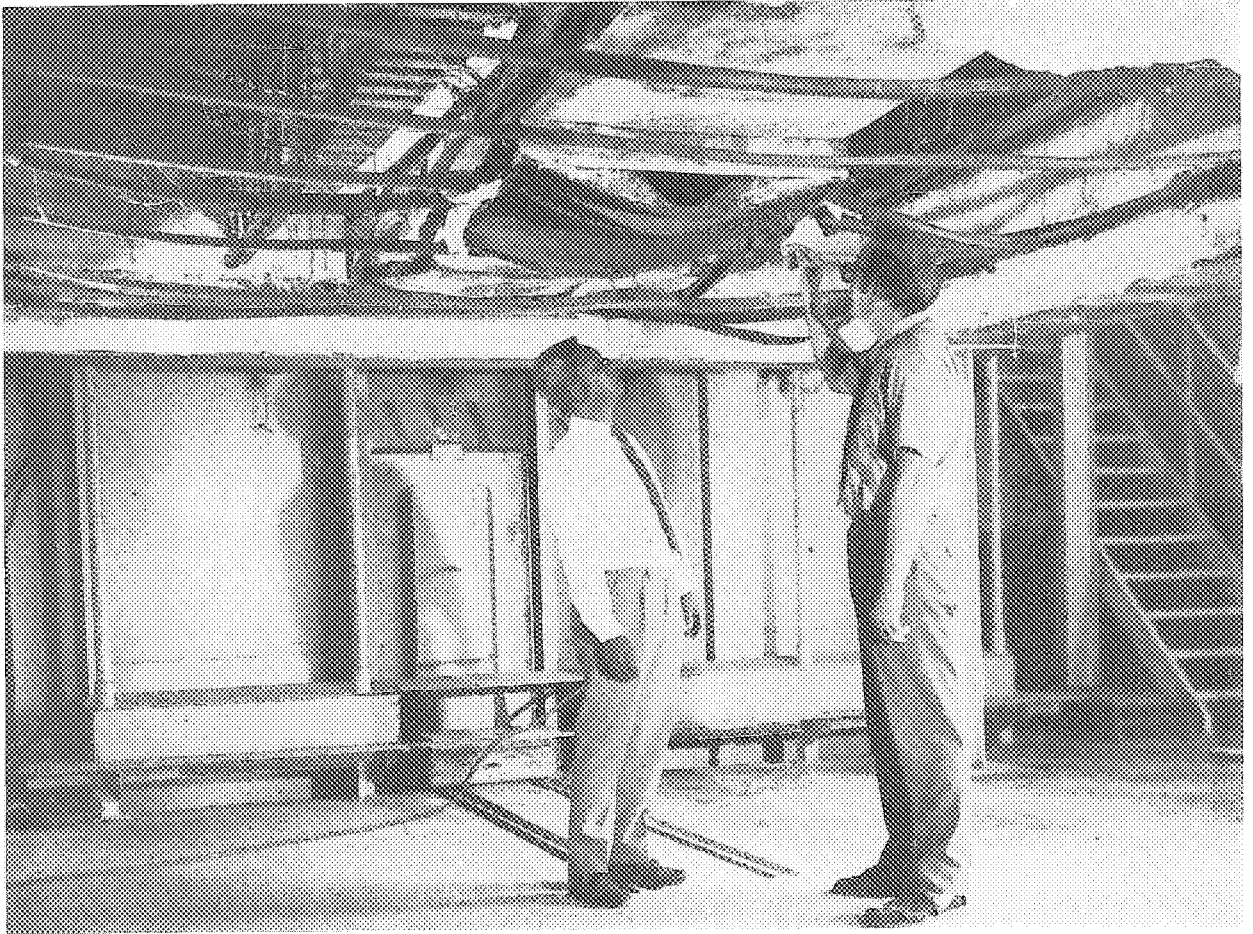

FIGURE 28 ASSEMBLY NO. 2 AFTER FIRE TEST