

NRC Publications Archive Archives des publications du CNRC

A six-foot solar-patrol radiotelescope Harrison, R.D.

For the publisher's version, please access the DOI link below./ Pour consulter la version de l'éditeur, utilisez le lien DOI ci-dessous.

Publisher's version / Version de l'éditeur:

<https://doi.org/10.4224/21274525>

Report (National Research Council Canada. Radio and Electrical Engineering Division : ERB); no. ERB-666, 1964-07

NRC Publications Archive Record / Notice des Archives des publications du CNRC :

<https://nrc-publications.canada.ca/eng/view/object/?id=d83a3303-6db5-4aaf-8058-c79bbc8ba0b4>

<https://publications-cnrc.canada.ca/fra/voir/objet/?id=d83a3303-6db5-4aaf-8058-c79bbc8ba0b4>

Access and use of this website and the material on it are subject to the Terms and Conditions set forth at

<https://nrc-publications.canada.ca/eng/copyright>

READ THESE TERMS AND CONDITIONS CAREFULLY BEFORE USING THIS WEBSITE.

L'accès à ce site Web et l'utilisation de son contenu sont assujettis aux conditions présentées dans le site

<https://publications-cnrc.canada.ca/fra/droits>

LISEZ CES CONDITIONS ATTENTIVEMENT AVANT D'UTILISER CE SITE WEB.

Questions? Contact the NRC Publications Archive team at

PublicationsArchive-ArchivesPublications@nrc-cnrc.gc.ca. If you wish to email the authors directly, please see the first page of the publication for their contact information.

Vous avez des questions? Nous pouvons vous aider. Pour communiquer directement avec un auteur, consultez la première page de la revue dans laquelle son article a été publié afin de trouver ses coordonnées. Si vous n'arrivez pas à les repérer, communiquez avec nous à PublicationsArchive-ArchivesPublications@nrc-cnrc.gc.ca.



ERB-666

UNCLASSIFIED



NATIONAL RESEARCH COUNCIL OF CANADA
RADIO AND ELECTRICAL ENGINEERING DIVISION

Ser *C.2*
QC1
N21
ERB
no. 666

422
NRC/REE
Doc. No.
E 16 64

ANALYZED

A SIX-FOOT SOLAR-PATROL RADIOTELESCOPE

RD
R. D. HARRISON

ON LOAN

from
National Research Council
Radio & E.E. Division
Document Control Section

OTTAWA

JULY 1964

NRC # 22082

ABSTRACT

An outline of the mechanical features of a six-foot solar-patrol radiotelescope mounted equatorially for use at latitudes of about 45° is given. A feature of this telescope is the totally enclosed worm drives used on both axes.

A SIX-FOOT SOLAR-PATROL RADIOTELESCOPE

- R.D. Harrison -

Since the end of World War II the Radio and Electrical Engineering Division has made a daily record of the sun's radiation on a wavelength of 10 centimeters. At first, this was done at the Metcalfe Road Field Station, at the present Ottawa city limits. However, owing to the high level of interference at this site, a new one, known as the "Goth Hill Observatory" was chosen, some 5 miles farther south. The instrument used for all these observations was a four-foot-diameter paraboloid mounted on a war surplus naval-radar rotator, modified to provide a polar axis and to give a limited range of declination adjustment [1]. This instrument has operated continuously for about 18 years.

When radio interference at the Goth Hill Observatory became serious because of Ottawa's expansion, another site was chosen which was believed to be as far from encroachment as possible, consistent with low radio noise level and reasonable proximity to Ottawa. The new site, known as the "Algonquin Radio Observatory", is located at Lake Traverse on the CNR transcontinental railway near the centre of Algonquin Provincial Park. Construction work was started at this site in 1959, and laboratories and staff quarters have been added.

To transfer the continuous record of solar radiation at 10-cm wavelength to the new site required that a new radiotelescope similar to the old one be built, and that the two units be operated simultaneously for a year or two to correlate the performance of the two instruments. The new instrument is larger, the reflector being 6 feet in diameter instead of four, and the improved drive systems are totally enclosed, as opposed to the open gearing used on the initial instrument.

The general arrangement of the radiotelescope is shown in Fig. 1. The polar-axis drive gear box is mounted on a semi-circular pad at the left end of the channel-iron base and at 45° to it. The curved arm on the opposite end of the base supports the polar-axis steady bearing and the polar-axis data gear box (BI-23-15E). Between the polar-axis drive gear box and the polar-axis steady

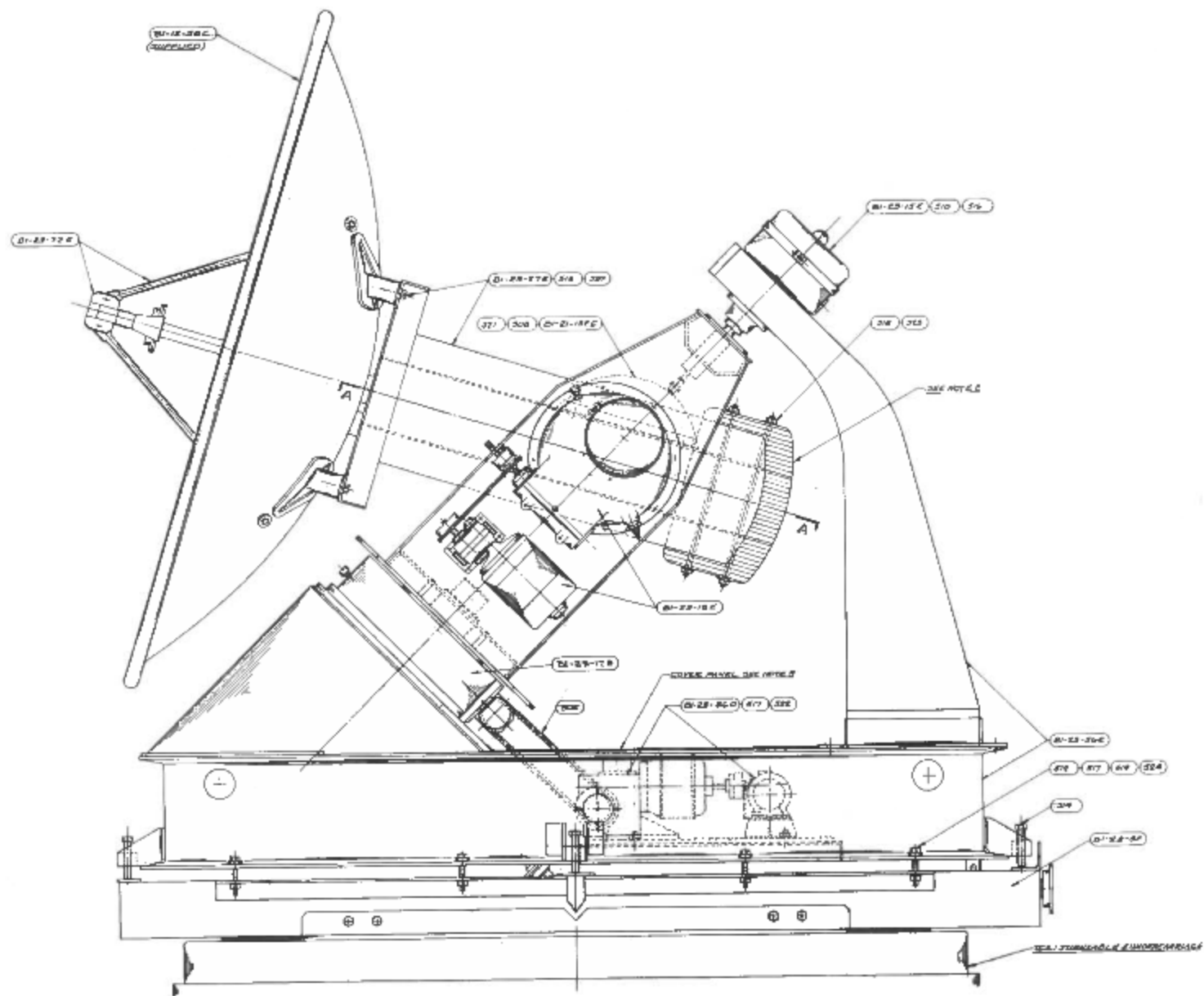

Fig. 1 General arrangement of six-foot radiotelescope

bearing is the polar-axis yoke. The declination frame (BI-23-27E) pivots in this yoke, and is supported on bearings on either side, one set of bearings being in the declination drive and data unit assembly (BI-23-13E). The declination frame has a lead counterweight at one end, and supports the 6-foot-diameter paraboloid reflector at the other end. Ten-centimeter rectangular waveguide is run from the horn, mounted at the focus of the paraboloid, through a rotating joint on the declination axis and then into the centre of the polar-axis yoke, where it goes down through the centre of the polar-axis gear box, through another rotating joint, and thence to the receiver in an adjoining building.

The telescope can be driven a little more than 180° about the polar axis, and from the horizon to the zenith, about 90° , in the declination axis. However, maximum polar travel is possible only with the telescope pointing to the celestial equator. For more southerly declination angles the polar travel is less.

To control these limits of travel so as to prevent damage to the unit, a specially shaped cam (BI-21-132C) mounted on the declination axis operates a push rod. This rod extends through the centre of the upper polar steady bearing into the polar data gear box. A circular rack cut on the end of this rod operates both polar-axis limit switches through two differential gears, so that the east and west limits are changed to suit the particular declination angle being used.

The declination axis is driven by the final worm drive in the declination drive unit (BI-23-13E). The worm shaft of this unit can be turned by a hand crank on the square end of its shaft, or, if the pinion on the drive sprocket is engaged, it is driven by a $\frac{1}{8}$ hp d-c motor with a variable speed control, at a speed range of about 10:1. This gives declination angular drive rates of 10° per minute maximum, and 1° per minute minimum.

Also, located in the declination drive unit are two 60-cycle synchros geared 1:1 and 36:1, respectively, for data presentation, and microswitches to limit the declination travel.

The polar-axis drive gear box is mounted on the 45° semi-circular surface of the unit base, already mentioned. The yoke rotates on two Timken roller bearings in this gear box, and suitable seals are provided to retain the lubricant.

The polar-axis worm gear is bolted to the yoke. It is a 150-tooth 8-diametral-pitch, $14\frac{1}{2}^\circ$ pressure-angle, bronze worm gear, with $1\frac{1}{4}$ " face, and is $18\frac{3}{4}$ " in diameter. The mating hardened-steel worm gear of $2\frac{1}{4}$ " pitch diameter runs on ball bearings in a separate housing. The surface where this joins the polar-axis gear box is sealed by an O-ring in a rectangular (with rounded corners) groove. This surface is machined at an angle of 3° to the tangent to the worm gear, and thus by loosening the bolts and sliding the housing, the backlash of the worm drive can be adjusted to a minimum.

The worm can be turned, when the pin in the sprocket clutch is pulled out, by a hand crank on the square end of the shaft. For normal operation, this pin is pushed in, and the drive is by chain from a motorized reducer with a $\frac{1}{8}$ hp 60-cycle reversible slewing motor, giving a slewing rate of about 14° per minute.

A magnetic clutch is mounted on an extended shaft of this motor and it can be engaged only when power is not applied to the slewing motor. When this clutch is engaged, it connects a $1/75$ hp Bodine synchronous tracking motor to the drive. This gives a tracking rate of 1 revolution of the telescope per solar day. All the elements of the polar drive are protected from the weather by their location beneath the cover of the unit base.

The polar-axis data gear box, located above the upper polar bearings, is shown in Fig. 2. The polar angular information is brought into the gear box through the outer shaft of the concentric pair, in the centre of the housing, through a bellows coupling. This drives a pair of 60-cycle synchro torque transmitters at ratios of 1:1 and 24:1.

Also driven directly from this gear train is a microswitch to control the starting position for the next day's run. The telescope returns automatically to the meridian at the end of the day's run. About one hour before sunrise, the telescope is driven to the eastern horizon. One side of each of two differentials is also driven from this same shaft; the outputs of these differentials drive limit switch cams to control the maximum limits of the hour angle of the telescope. The other inputs of these differentials are driven from a cam mounted on the declination frame. This changes the limits of the hour angle drives to suit various declination angles.

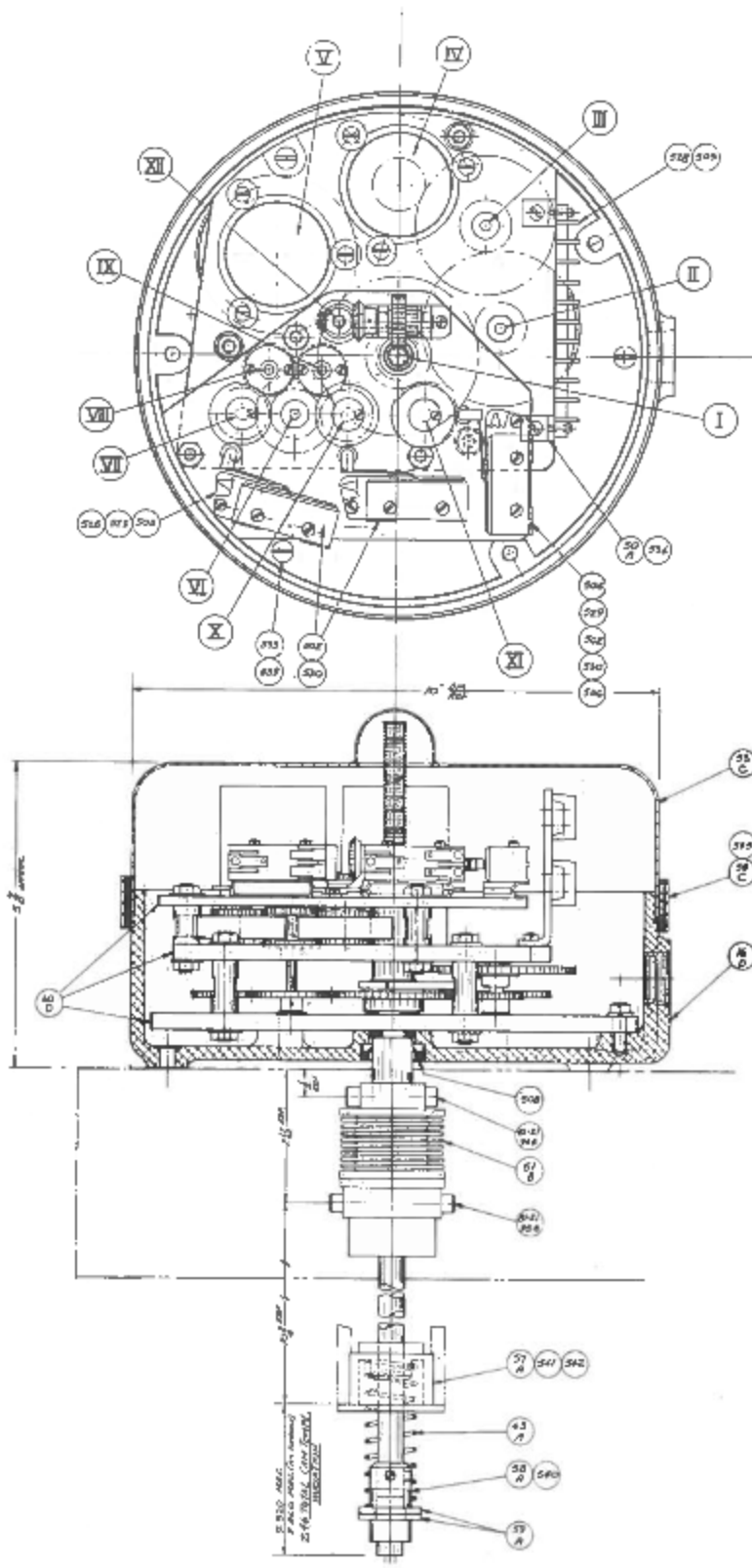

Fig. 2 Polar-axis data gear box

Two of these radiotelescopes are now in operation, and a third is being assembled. Of the two in use, one is at the Algonquin Radio Observatory; the other was initially trailer-mounted and operated at Grand-Mère, Que., during the total eclipse of the sun in July 1963. This unit will be installed permanently at Penticton, B.C., where it will be operated by the Dominion Observatory. The base of the unit was modified slightly because of the difference in latitude. The third radiotelescope will be used at the Algonquin Radio Observatory.

Reference

1. A.E. Covington, "NRC 10.7-centimeter radiotelescope and radiometer", NRC Report ERA-216, May 1952