

## NRC Publications Archive Archives des publications du CNRC

### The influence of blade profile and slots on the performance of a centrifugal impeller / Influence du profil de pales et fentes sur la performance d'un ventilateur centrifuge

Fowler, H. S.

For the publisher's version, please access the DOI link below. / Pour consulter la version de l'éditeur, utilisez le lien DOI ci-dessous.

#### **Publisher's version / Version de l'éditeur:**

<https://doi.org/10.4224/40003734>

*Mechanical Engineering Report (National Research Council Canada. Division of Mechanical Engineering. Engine Laboratory); no. ME-248, 1980-01*

#### **NRC Publications Archive Record / Notice des Archives des publications du CNRC :**

<https://nrc-publications.canada.ca/eng/view/object/?id=d6c67f5a-0b1b-4d25-9ba0-e8715523e545>

<https://publications-cnrc.canada.ca/fra/voir/objet/?id=d6c67f5a-0b1b-4d25-9ba0-e8715523e545>

Access and use of this website and the material on it are subject to the Terms and Conditions set forth at

<https://nrc-publications.canada.ca/eng/copyright>

READ THESE TERMS AND CONDITIONS CAREFULLY BEFORE USING THIS WEBSITE.

L'accès à ce site Web et l'utilisation de son contenu sont assujettis aux conditions présentées dans le site

<https://publications-cnrc.canada.ca/fra/droits>

LISEZ CES CONDITIONS ATTENTIVEMENT AVANT D'UTILISER CE SITE WEB.

**Questions?** Contact the NRC Publications Archive team at

PublicationsArchive-ArchivesPublications@nrc-cnrc.gc.ca. If you wish to email the authors directly, please see the first page of the publication for their contact information.

**Vous avez des questions?** Nous pouvons vous aider. Pour communiquer directement avec un auteur, consultez la première page de la revue dans laquelle son article a été publié afin de trouver ses coordonnées. Si vous n'arrivez pas à les repérer, communiquez avec nous à PublicationsArchive-ArchivesPublications@nrc-cnrc.gc.ca.



National Research  
Council Canada

Conseil national  
de recherches Canada

3

# THE INFLUENCE OF BLADE PROFILE AND SLOTS ON THE PERFORMANCE OF A CENTRIFUGAL IMPELLER

by

H. S. Fowler

Division of Mechanical Engineering

OTTAWA

JANUARY 1980

NRC NO. 18123

MECHANICAL ENGINEERING

REPORT

ME-248

**THE INFLUENCE OF BLADE PROFILE AND SLOTS  
ON THE PERFORMANCE OF A CENTRIFUGAL IMPELLER**

**INFLUENCE DU PROFIL DE PALES ET FENTES  
SUR LA PERFORMANCE D'UN VENTILATEUR CENTRIFUGE**

by/par

**H.S. Fowler**

## SUMMARY

As part of the program of studies on centrifugal impellers, the problem of instability at low flows was investigated. The major cause was found to be flow detachment from the impeller vanes.

Slotted blades were found to be the most effective means of delaying this detachment, and extending the working range of the blower.

Low speed studies were confirmed by a test program on a high speed machine, where it was demonstrated that the improved flow range was accompanied by a general increase of efficiency.

The design and placement of the slots is discussed.

## RÉSUMÉ

Les résultats présentés proviennent de travaux expérimentaux relatifs à l'instabilité des écoulements à faible régime entrepris dans le cadre d'un programme d'étude des ventilateurs centrifuges. Il a été découvert que le phénomène était dû principalement au détachement du fluide des pales de la couronne mobile.

L'emploi de pales fendues s'est dans ce cas révélé le moyen le plus efficace pour retarder le détachement en question et accroître ainsi le rendement du ventilateur.

Les données obtenues à petite vitesse ont été confirmées dans un programme d'essais sur une machine de haut régime dans lequel l'amélioration de la plage d'écoulement s'est accompagnée d'une augmentation générale de la performance.

La conception et l'emplacement des fentes font l'objet d'une analyse détaillée.

## CONTENTS

	Page
SUMMARY .....	(iii)
APPENDICES .....	(v)
1.0 INTRODUCTION .....	1
2.0 LOW SPEED EXPERIMENTS .....	1
2.1 Description of Blades and Impeller .....	2
2.2 Experimental Procedure .....	3
2.3 Analysis of Results — Flow Quantity .....	3
2.4 Discussion of Results .....	3
2.5 Conclusions from Low Speed Results .....	4
3.0 HIGH SPEED EXPERIMENTS .....	5
3.1 Instrumentation .....	5
3.2 Description of Blading .....	5
3.3 Test Procedure .....	5
3.4 Analysis .....	5
3.5 Presentation and Discussion of Results .....	6
3.6 Conclusions from High-Speed Experiments .....	6
4.0 REFERENCES .....	6

## ILLUSTRATIONS

Figure	Page
1 NRC Low Speed Centrifugal Impeller Test Rig .....	7
2 Rotor and Air Passage Profile .....	8
3 Pressure Rise ~ Flow Characteristics (70 RPM), Blade Set VB1 [Swept-Back] Variants A, B, C, Cm .....	9
4 Pressure Rise ~ Flow Characteristics (70 RPM), Blade Set VB2 [Straight Blades] Variants A, B, C, Cm .....	10
5 Pressure Rise ~ Flow Characteristics (70 RPM), Blade Set VB3 [Radial Exit Blades] Variants A, B, C, Cm .....	11
6 Pressure Rise ~ Flow Characteristics (70 RPM), Variant (A) — Aerofoil Blades, Sets VB1, 2 & 3 .....	12
7 Pressure Rise ~ Flow Characteristics (70 RPM), Variant (B) — Slotted Aerofoil Blades, Sets VB1, 2 & 3 .....	13

## ILLUSTRATIONS (Cont'd)

Figure		Page
8	Pressure Rise ~ Flow Characteristics (70 RPM), Variant (C) — Thin Plate Blades, Sets VB1, 2 & 3 .....	14
9	Pressure Rise ~ Flow Characteristics (70 RPM), Variant (C <sub>m</sub> ) — Thin Plate Blades (Closely Spaced), Sets VB1, 2 & 3 .....	15
10	Diagram of High Speed Centrifugal Compressor Rig .....	16
11	Solid and Slotted Blades .....	17
12	Fan Performance (High Speed Rig) .....	18
A-1	Static Tests — Smoke Visualization of Flow (90° Cambered Aerofoil) .....	23
A-2	Static Tests (Various Slotted Blades) .....	24
A-3	Static Tests (Slot and Deflector) .....	25
A-4	Static Tests (Vortex Generators) .....	26
B-1	C-4 Aerofoil Data .....	29
B-2	Thin-Plate Blade Data .....	30
B-3	Blade Sets VB1-A, B, C, and C <sub>m</sub> .....	31
B-4	Blade Sets VB2-A, B, C, and C <sub>m</sub> .....	32
B-5	Blade Sets VB3-A, B, C, and C <sub>m</sub> .....	33
C-1	Slot Descriptive Nomenclature .....	37
C-2	Blade "E" — Two Slots .....	38
C-3	Blade "E" — Two Slots .....	39

## APPENDICES

Appendix		Page
A		19
A.1	Flow Detachment in Impeller Channels, and Initial Experiments to Select the Most Promising Preventive Device .....	19
A.2	Initial Static Tests .....	19

APPENDICES (Cont'd)

Appendix		Page
	A.2.1 Leading Edge Slat .....	20
	A.2.2 Deflector .....	20
	A.2.3 Vortex Generators .....	20
A.3	Stability .....	21
A.4	Conclusions .....	21
B		27
B.1	Index of Blades Tested .....	27
C	Discussion of Slots in the Blades .....	35
C.1	Description of Blades .....	35
C.2	Description of Slots .....	35
C.3	Comparison with Foster's Paper (AIAA 71-96) .....	36

## THE INFLUENCE OF BLADE PROFILE AND SLOTS ON THE PERFORMANCE OF A CENTRIFUGAL IMPELLER

### 1.0 INTRODUCTION

An experimental investigation of the flow in centrifugal impellers took place in the Engine Laboratory from 1963 to 1976. It became clear during the program that the detachment of flow from the blade surfaces is one of the major influences on the poor distribution and stability of flow in the impeller channels. After a general exploration of this flow detachment, it was concluded that slotted blades were the most promising means of delaying instability and flow detachment as flowrate through the impeller was reduced. A study on this subject was therefore included in the general program on centrifugal impellers, and is reported herein.

A brief discussion of flow detachment, and the various preventive methods tested before selecting slots as the most promising is given in Appendix A.

Qualitative experiments on three sets of blading, with and without slots, were then carried out in a rotating impeller on the Low Speed Centrifugal Compressor Rig. The flow patterns, stability characteristics and stall mechanisms were studied in detail. Following that program, a complete set of Pressure rise/Flow characteristics was obtained for a slightly extended family of blading on the same Low Speed Rig. These characteristics are presented, and their implications discussed, in the present report.

Since it was shown that slotted blades appear to present a practical method of delaying flow detachment and unstable flow in a centrifugal blower impeller, it was necessary to assess quantitatively the capabilities of such a system, applied to an actual high-speed impeller. The final series of experiments, carried out on the high speed compressor rig, fitted with two sets of similar blading, one slotted and the other unslotted, is described at the close of this report.

The ultimate aim of the whole program was to raise the efficiency and broaden the operating range of centrifugal blowers.

A centrifugal impeller is usually considered as a group of rotating quasi-radial channels, but it is also valid to regard it as a group of aerofoils rotating in an airflow whose natural path relative to them is a spiral. The work done by the impeller is therefore characterized by the degree to which the aerofoil deflects the flow outwards from its undisturbed spiral path. The force doing this work is in fact the lift generated by the aerofoils.

The blower characteristic is determined by the maximum lift coefficient generated by the aerofoil blades, and the range of incidence angle (controlled by the incidence/RPM function) over which this lift-coefficient can be maintained.

The maintenance of high lift-coefficient over a wide range of incidence is achieved in normal aerofoil practice by using slots, and early experiments in the program defined the twin-slotted configuration which appeared to be the optimum compromise between wide range, high lift-coefficient, and low loss, for this application.

### 2.0 LOW SPEED EXPERIMENTS

Three sets of blades (see Appendix B, Figs. B-3, B-4, and B-5) were therefore designed for the LSCC Rig (see Fig. 1), to fit into an impeller assembly which had already been extensively tested (see Refs. 1 and 2).

Each of these sets of blades was built in duplicate, one built of solid blades (A) and one built with slots (B), and the unslotted and slotted builds of each set were tested over the same range of RPM

and outlet throttle openings. Slow-motion movies of the flow visualized with smoke were taken at all conditions, and pressure rise and volume flow measurements made.

The range of blades tested was increased by including a group of thin-plate blades (similar to those reported in Ref. 2) conforming to the camber lines of each of sets 1, 2, and 3. These are identified as variant "C" and were assembled in two builds, "C" and "Cm", where Cm had an increased number of blades in the ring.

The Pressure rise/Flow characteristics of these blade assemblies are presented in the present report, with brief comments on their performance.

An index of the builds tested is given in Appendix B. Layouts of the impeller and measurement stations, and of the blade builds, are given in Figures 2 and B-3, B-4, and B-5. Fan performance characteristics of the various builds are shown in Figures 3 through 9.

For clarity, a very brief index of builds follows:

### BRIEF INDEX OF BUILDS

Blade Form	Camberline Shape		
	Curved Swept-Back	Straight Swept-Back	Curved Radial Exit
Solid Aerofoil	VB1-A	VB2-A	VB3-A
Slotted Aerofoil	VB1-B	VB2-B	VB3-B
Thin Plate	VB1-C	VB2-C	VB3-C
Thin Plate (Close Spaced)	VB1-Cm	VB2-Cm	VB3-Cm

#### 2.1 Description of Blades and Impeller

The impeller was common to all three sets of blading, and is shown in Figure 2. It is in fact the impeller described in Reference 2 which also describes the unslotted version of the first of the present three sets of blades, which are designated the VB Series.

The three sets of blading VB1, VB2, and VB3, in their aerofoil unslotted (VB1-A, etc.) and slotted (VB1-B, etc.) forms, and in their thin plate form (VB1-C and VB1-Cm, etc.) are shown in Appendix B, Figures B-3, B-4, and B-5. The aerofoil blades are of C-4 section (see Appendix B) with max. thickness of 10% C occurring at 30% C behind the leading edge. The thin plate blades are of constant thickness (Appendix B).

The camberline varied in the three sets, being a circular arc in VB1 and VB3, and a straight line in VB2. The chord lengths were different in all three sets, and were determined by the outlet blade angles, and the fixed inner and outer impeller diameters. The blade inlet angle was the same for all three sets, but the arbitrarily selected blade outlet angle was different for each set.

The blade of VB1 was identical to that shown in Reference 2 and was a typical heavily swept-back curved blade.

The blade of VB3 had the same inlet angle, but was oppositely-curved, with a radial exit. This could be regarded as analogous to a "radial" impeller, with integral curved inducer blades.

The blade of VB2 was intermediate between these two, having the same inlet angle, and a straight camberline extending from this.

This arrangement led inevitably to different chord lengths for the three sets, and the number of blades in each build was chosen to hold the pitch/chord ratio approximately constant, where the circumferential pitch of the blade leading edges was used as the "pitch" figure. This decision was an arbitrary one, based on axial compressor practice, and appears to have led to too small a number of blades in the VB3 set, where the performance at low flows could probably have been improved by a larger number of blades.

In the case of the thin plate blades, additional builds were assembled (the Cm builds) in which larger numbers of blades were put in the impeller ring, corresponding to the numbers tested in the work described in Reference 2.

The slots were designed in accordance with the method described in Appendix C and are shown in Figures B-3, B-4, and B-5.

## 2.2 Experimental Procedure

For details of the experimental procedure, the reader is referred to Reference 1. In addition to the measurements described there, a total pressure kiel probe was inserted into the vaneless diffuser space outside the impeller, at 1.07 m radius (0.33 m outside the impeller tip). This probe was mounted at mid-height in the channel, to measure the total pressure rise across the impeller. The probe was aligned to the local airflow for each reading, and the pressures read on a micromanometer.

A special micromanometer was designed and constructed for this task, as reasonably rapid reading combined with great sensitivity was required. The instrument, in which null-point was observed when an underwater needle met its reflection in the water surface as viewed from below the water through an optical system, was accurate and repeatable to better than 0.025 mm water pressure. Careful technique on the part of the rig operator and the observer allowed consistent fan performance curves to be established with total pressure rises ranging from 2.00 mm H<sub>2</sub>O down to 0.18 mm H<sub>2</sub>O.

## 2.3 Analysis of Results — Flow Quantity

From the hot-wire traverses in the inlet duct, it was possible to plot the inlet velocity profile, divide the inlet into concentric annulae of equal area, and hence calculate accurately the volume-airflow through the machine. This flow quantity is plotted against the total pressure rise in the fan, at the series of throttle openings tested, in the curves of Figures 3 through 9.

## 2.4 Discussion of Results

This section should be read in conjunction with the physical picture of the flow, particularly regarding its stability, presented in Reference 1.

From a careful study of the pressure rise vs. flow curves (Figs. 3 through 9), the following observations may be made.

- (i) There is surprisingly little variation between the curves for bladings A, B, C, and Cm, within each of the sets 1, 2, and 3.
- (ii) The design point (approximately the maximum efficiency point) and indeed the whole curve moves to a higher pressure rise (for any set throttle opening) with the change from set 1 to 2 to 3, and hence to higher flows in the same progression.
- (iii) In the range of flows above the design point, an unslotted blade gives a higher pressure ratio than the corresponding slotted blade. However, the slotted blade gives a slightly higher pressure rise just around the design point, particularly in sets 2 and 3.
- (iv) At flows below the design point, in sets 1 and 2, flow visualization shows that the slotted blade gives stable flow at a higher pressure rise than the unslotted one. For set 3, however,

the slotted blades give a lower pressure rise than the unslotted ones below the design point. But it is noted again from visualization that the unslotted set 3 blading gives unstable flow in this region, and is therefore of little practical use at low flows.

- (v) The thin plate blades give a higher design flow and the same max. pressure rise as the unslotted aerofoils in sets 1 and 3, and give a higher max. pressure rise than the unslotted aerofoil blades of set 2.

The pressure rise of the thin plate blades falls off slightly more steeply at high flows than that of the aerofoil blades, slotted or unslotted, in all of sets 1, 2, and 3.

- (vi) The thin plate build with the larger number of blades ( $C_m$ ) gives a higher pressure rise than that with the fewer blades ( $C$ ). However  $C$  has a flatter characteristic with pressure rise falling off less steeply. The maximum flow capacity of  $C$  is also higher than that of  $C_m$ . Both  $C$  and  $C_m$  builds stall at approximately the same point.
- (vii) Location of the stall point was difficult in all the experiments. It was only possible to say that it lay somewhere between two test points, after analysing ciné films of visualized flow. The positive location of the stall points is most important, and is further discussed in the high speed quantitative experiments described in the following section.

## 2.5 Conclusions from Low Speed Experiments

From the above somewhat complex set of observations, the following conclusions have been drawn.

- (i) Maximum flow capacity is shown by the thin plate blades  $C$ , which obstruct the passage appreciably less than other blading.
- (i(a)) The maximum pressure rise of the  $C$  blading can be raised by adding more blades (build  $C_m$ ), at the expense of a slight loss of max. flow capacity.
- (ii) The best stability at low flow, and in sets 1 and 3 the highest maximum pressure rise, are obtained from the slotted aerofoil blades, the type B. These qualities are obtained at the expense of a reduced maximum flow in type "B". The air in effect "blows through the blades" at high flows.
- (iii) It appears likely, from inspection of the airflow patterns, that the slotted blades will be a little noisier (white noise) at high flows, but much quieter at low flows, owing to lack of stall. This may reflect in higher efficiency correlated with lower noise levels.
- (iv) Slots give least advantage in terms of pressure rise and increased flow stability in a low-head-rise swept-back impeller, which already has a wide range of stable operation.

Slots show to advantage in widening the low-flow stable operating range of high-head (more nearly radial blade) impellers.

- (v) The thin plate blades, ( $C$  and  $C_m$  builds) have good performance over a relatively narrow range of flow near the design point (particularly the  $C_m$  build with more blades). As the flow is reduced, these blades quickly stall, leading to compressor surge (cyclic stall).

At flows far above design point also, the thin plate blading has a poor performance, particularly the  $C_m$  build. This relatively small working range follows logically from the narrow incidence range of thin plate aerofoils.

- (vi) It was not possible to locate the stall points positively, or to measure blower efficiency, in this series of experiments.

### 3.0 HIGH-SPEED EXPERIMENTS

The high speed test rig shown in Figure 10 was assembled for the tests. The impeller was driven by an air turbine via a positive belt drive with a reduction ratio of 1.8:1 and a quill shaft for measuring the torque required to drive the rotor. The test impeller inhaled atmospheric air through a wooden bellmouth and a straight, cylindrical duct 221 mm in diameter and some 1.5 m long, and discharged through a volute equipped with a motor-driven sliding plate valve at its exit.

Rotor speed was controlled by throttling the compressed air supply to the drive turbine, and the fan pressure ratio was varied by adjusting the plate valve at the volute exit.

#### 3.1 Instrumentation

Instrumentation throughout was simple and direct. Pressures were measured with a bank of manometers, inlet air temperature with a resistance thermometer, and fan speed with an electronic counter triggered by a proximity pickup and a notched wheel on the fan drive shaft. Atmospheric pressure was measured for each test with a mercury barometer.

Flush wall tapings provided the static pressures at the fan inlet and outlet. The total pressure at the outlet was sensed by a traversing total head probe mounted at the same radial position as the outlet static tapping, and was measured at five axial positions so chosen that each was at the centre of an element of equal circumferential area. The probe was yawed to find the maximum value for each of these positions.

The torsional deflection of the quill shaft was measured to find the impeller drive torque, using the system of mirrors shown in Figure 10. A laser beam trained on a plane mirror mounted at the driven end of the quill shaft was reflected to a fixed section of cylindrical mirror, thence to a plane mirror at the other end of the quill shaft, and finally to a fixed scale visible from the observer's position. A static calibration gave the conversion from scale reading to torque.

#### 3.2 Description of Blading

The blades used were identical, in all but size, with those designated VB2-A and VB2-B in the previous experiments (see Appendix B), and are sketched in Figure 11. Each impeller carried eleven uncambered blades of C-4 aerofoil section riveted and cemented between two aluminum discs of 458 mm diameter comprising the impeller. The span of each blade, and hence the spacing between the discs, was 25 mm. The two sets of blades were identical except for the slots in the VB2-B blades.

#### 3.3 Test Procedure

The parameter for each test run, comprising five or six points, was the "non-dimensional" speed,  $N/\sqrt{T}$ , which was maintained constant by continual adjustment of the throttling valve in the air supply to the driving turbine. Mechanical considerations dictated an upper rotational speed limit of 5000 revolutions per minute, thus restricting the pressure ratio to quite low values.

For each speed, the fan outlet throttle was used to vary the delivery pressure from a minimum at full open throttle to the maximum that could be reached without surging. Surge could usually be detected by ear, the airborne vibration being clearly audible even though ear defenders were worn. An additional, though less definite, indication was provided by the increased vibration of the laser beam spot on the torque meter scale. Surge was not readily detectable at the lowest speeds, where it was often possible to close the throttle completely without noticeable distress.

#### 3.4 Analysis

The volumetric flow rate through the fan was calculated from the inlet duct static depression, using a discharge coefficient of 0.991 for a typical inlet pipe Reynolds number of  $2.10^5$ .

The equivalent total pressure at the fan exit was calculated from the five measured fan outlet total pressures by an iterative method, using the arithmetic average of the five measured pressures as the first trial value.

The aerodynamic power delivered by the fan in watts is simply the product of the flow rate in cubic metres per second and the pressure rise across the fan in pascals.

Similarly, the shaft power absorbed by the fan is the product of shaft torque in newton metres and the rotational speed expressed in radians per second. This neglects the frictional losses in the two fan-shaft bearings, but this will be small and has been omitted.

The overall efficiency of the fan is then the quotient of delivered power divided by shaft power.

### 3.5 Presentation and Discussion of Results

The test results for both the slotted and unslotted blades are superimposed for comparison in Figure 12. The conventional presentation has been employed, in which fan pressure ratio is plotted against "non-dimensional" volumetric flow rate, with "non-dimensional" speed as parameter. Superimposed on this plot, for each impeller, are lines of constant efficiency.

Examination of Figure 12 shows that both the pressure ratio and the surge characteristic are improved by the addition of slots. While the improvement is significant at the higher pressure ratios, the performance at low pressures is practically unaffected. More surprisingly, the slots improve the peak efficiency from about 75% to almost 85%. The lowest efficiency, with fully-opened throttle, is unaffected by the slots, and remains at about 40%.

### 3.6 Conclusions from High-Speed Experiments

The tests described suggest that a useful improvement in the surge limit and some increase in pressure ratio may be expected from the addition of slots to the blades, and that this improved performance is attended by a significant increase in efficiency.

## 4.0 REFERENCES

1. Fowler, H.S. *Aerodynamic Tests on a Centrifugal Fan Impeller Model with Swept-Back Blades.*  
NRC DME Report ME-237, May 1971.
2. Fowler, H.S. *Comparison of Thin Plate and Thick Aerofoil Blades in a Centrifugal Fan.*  
NRC DME Report ME-238, August 1971.
3. Schubauer  
Spangenberg *Forced Mixing in Boundary Layers.*  
Journal of Fluid Mechanics, Vol. 8, 1960, pp. 10-32.
4. Foster, D.N. *The Flow Around Wing Sections with High-Lift Devices.*  
A.I.A.A. Paper No. 71-96, January 1970.

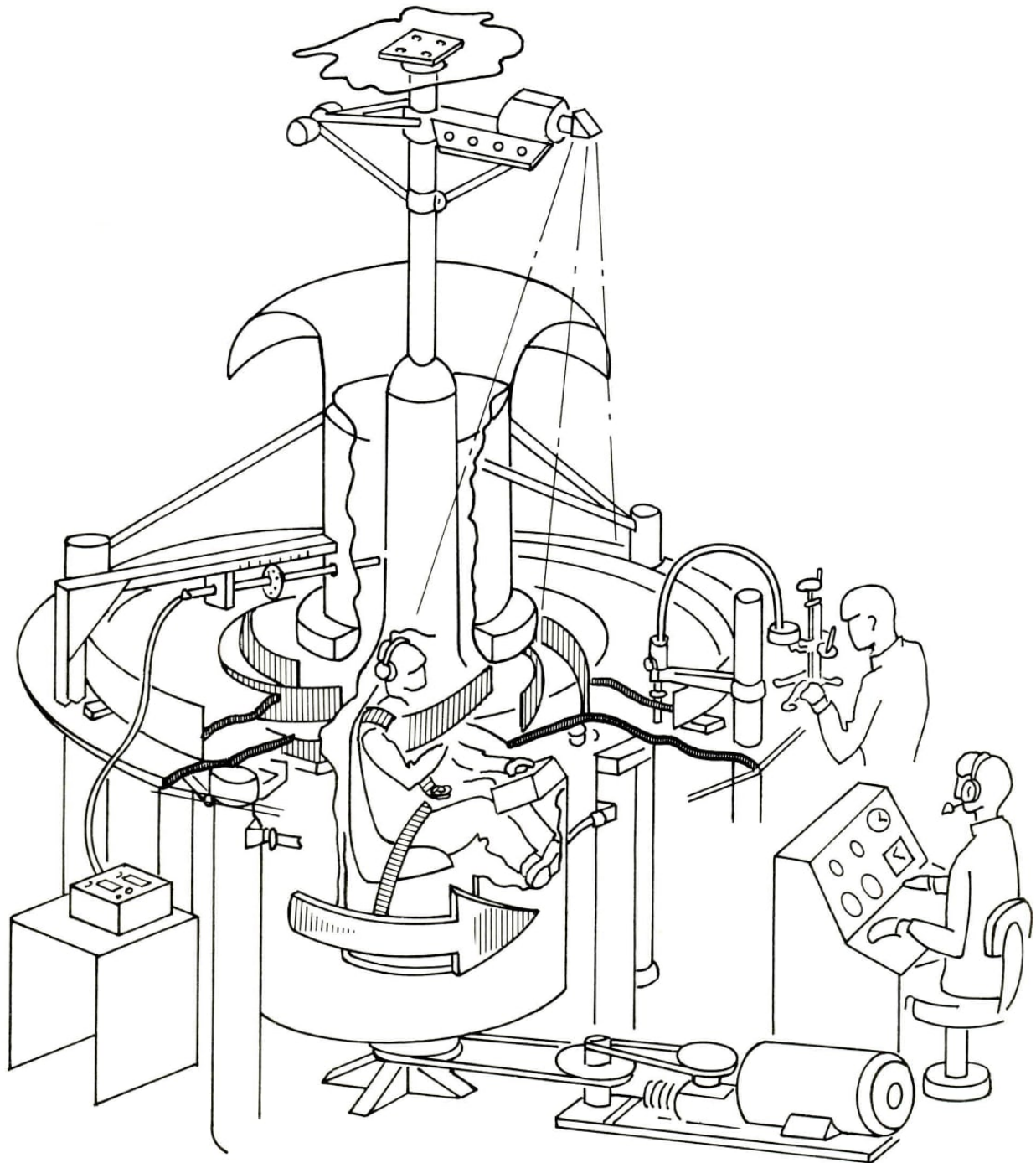

FIG. 1: NRC LOW SPEED CENTRIFUGAL IMPELLER TEST RIG

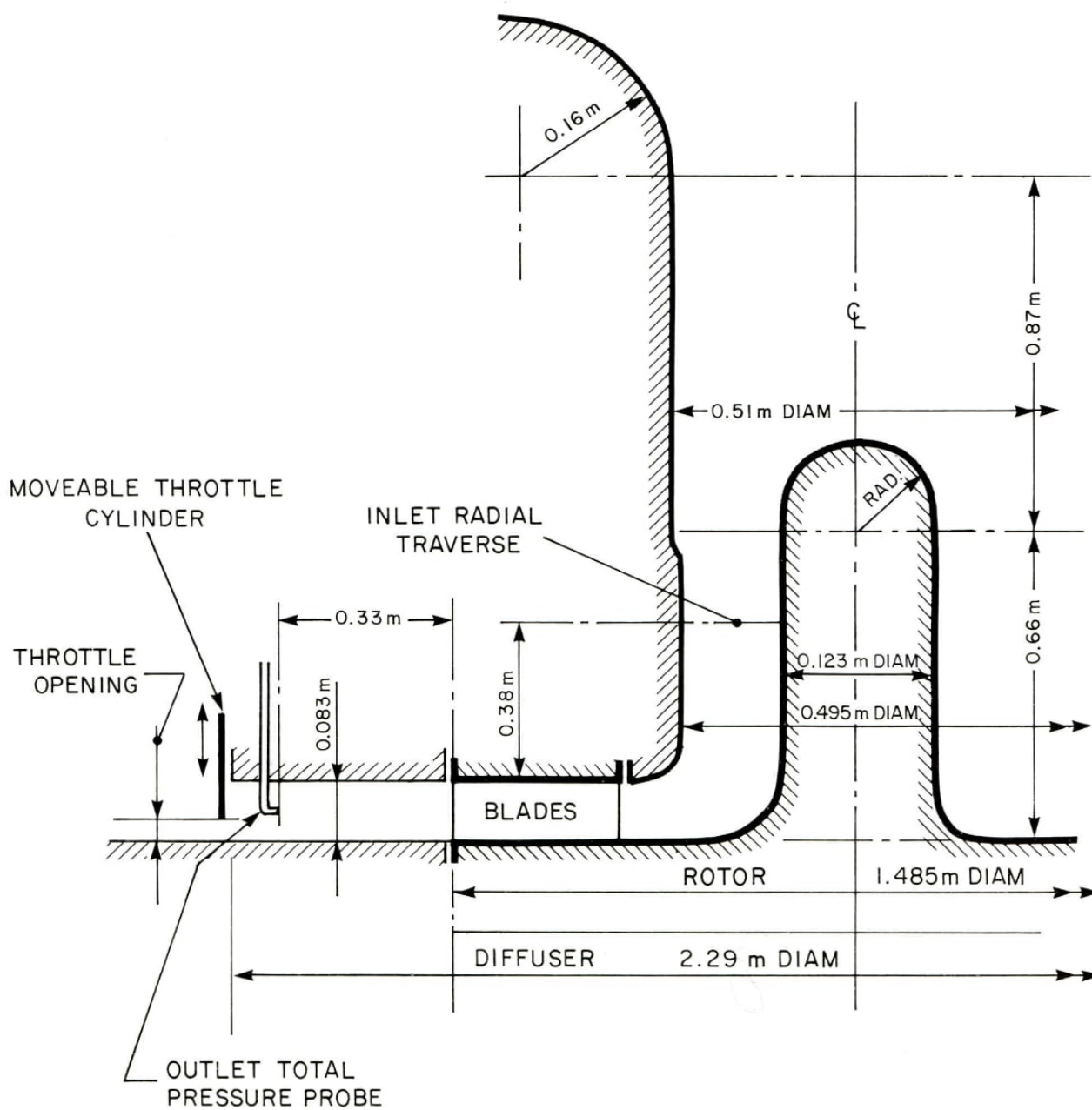

FIG. 2: ROTOR AND AIR PASSAGE PROFILE

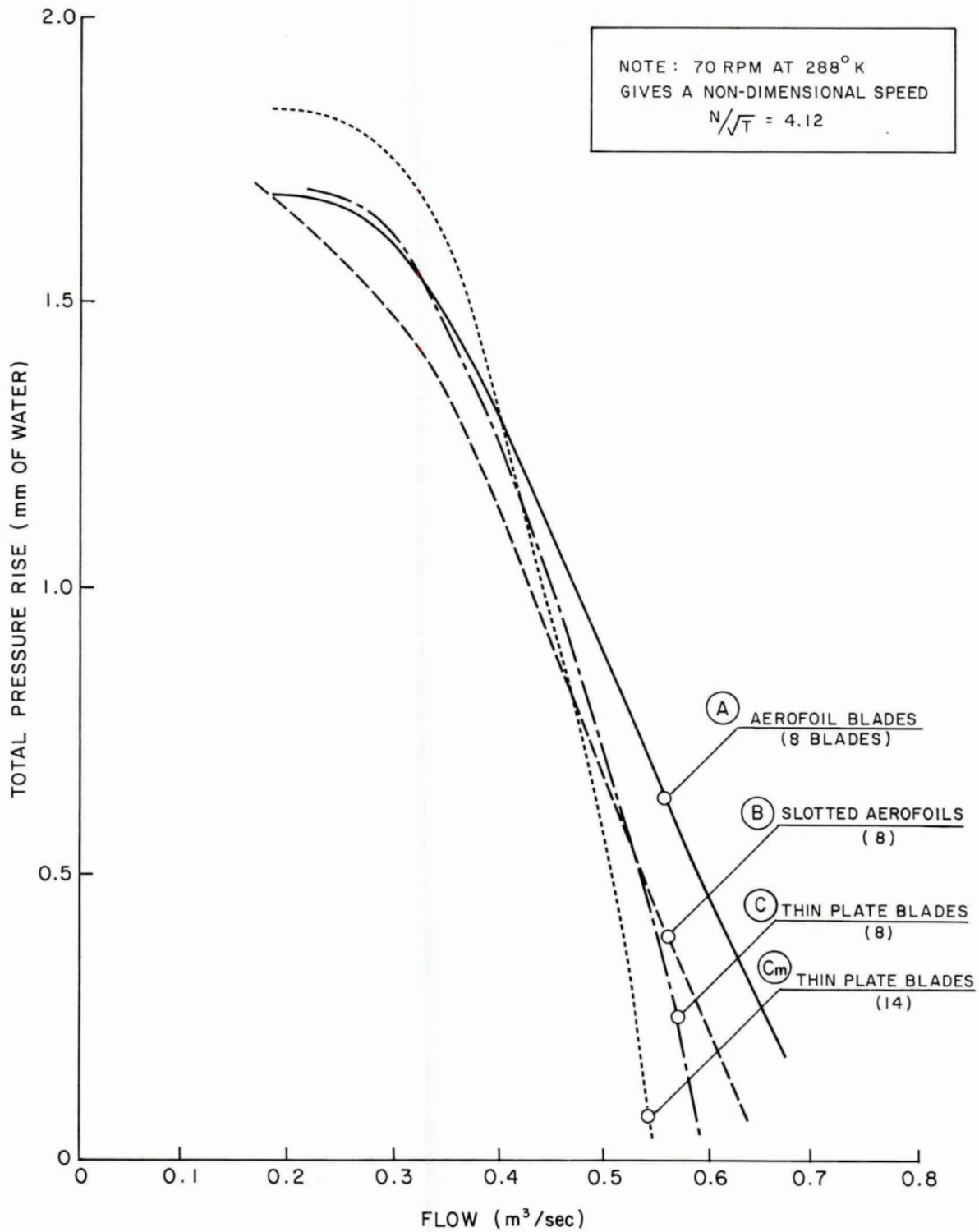

FIG. 3: PRESSURE RISE ~ FLOW CHARACTERISTICS (70 RPM)  
BLADE SET VB1 [SWEEP-BACK] VARIANTS A, B, C, Cm

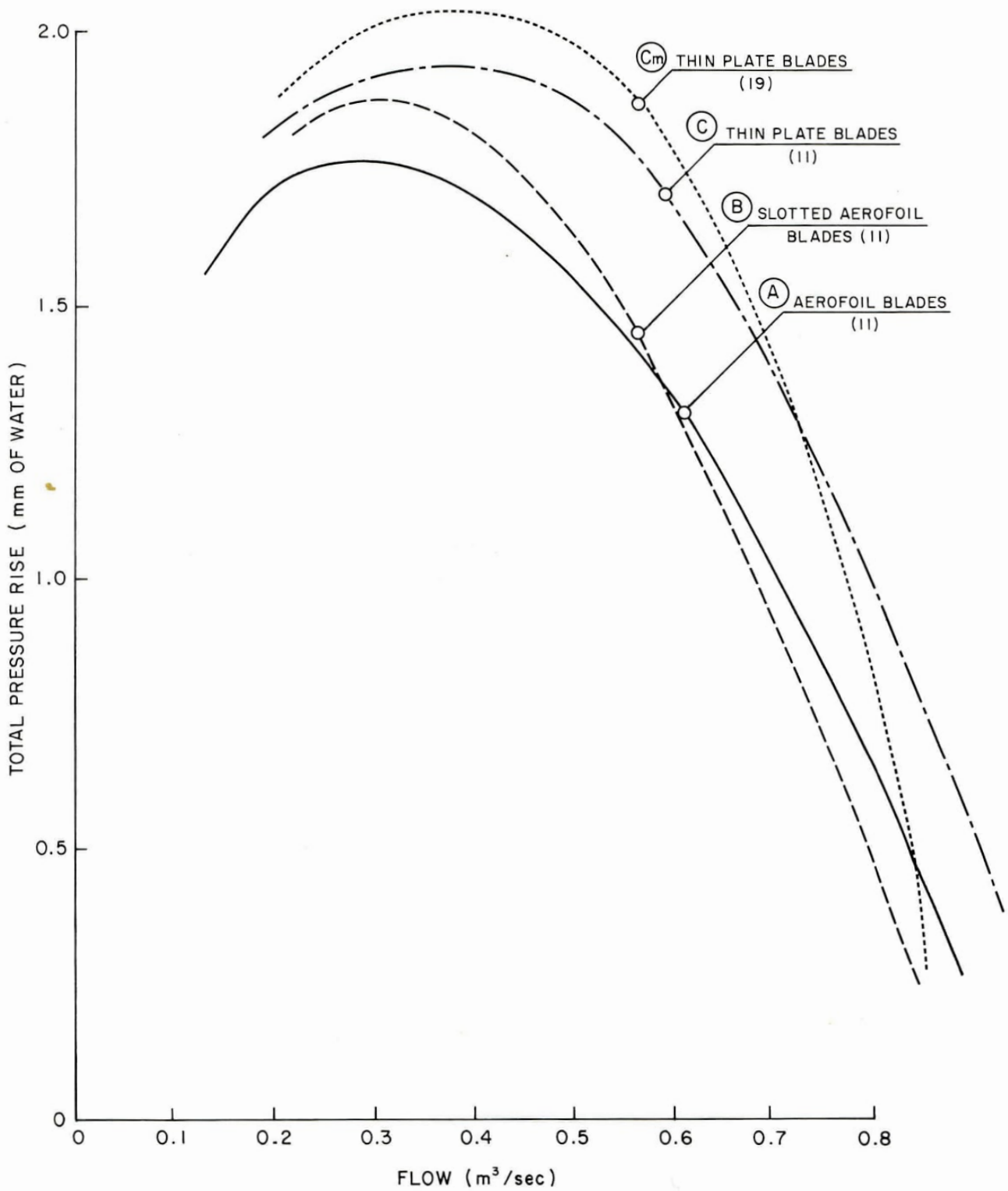

FIG. 4: PRESSURE RISE ~ FLOW CHARACTERISTICS (70 RPM)  
BLADE SET VB2 [STRAIGHT BLADES] VARIANTS A, B, C, Cm

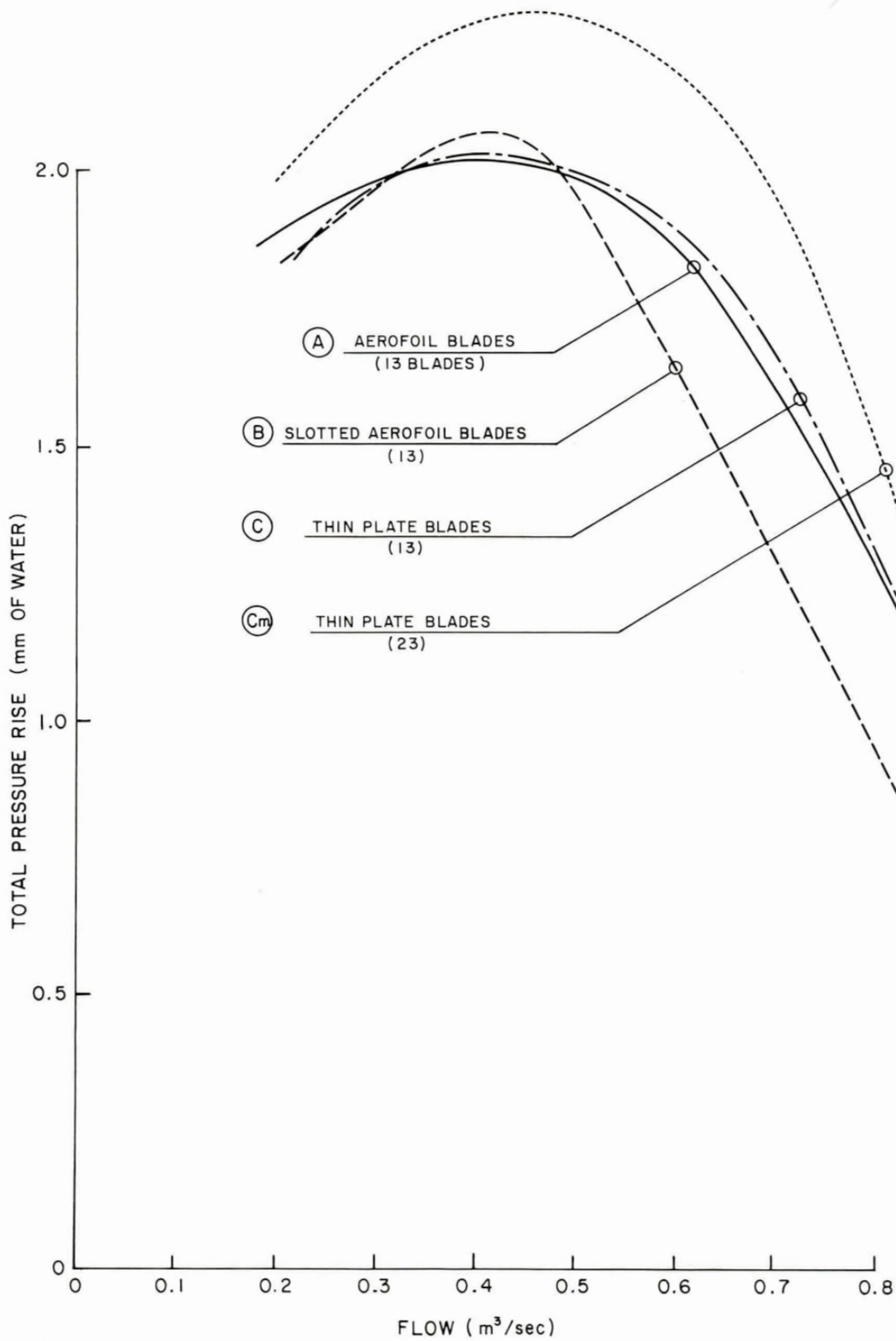

FIG. 5: PRESSURE RISE ~ FLOW CHARACTERISTICS (70 RPM)  
BLADE SET VB3 [RADIAL EXIT BLADES] VARIANTS A, B, C, Cm

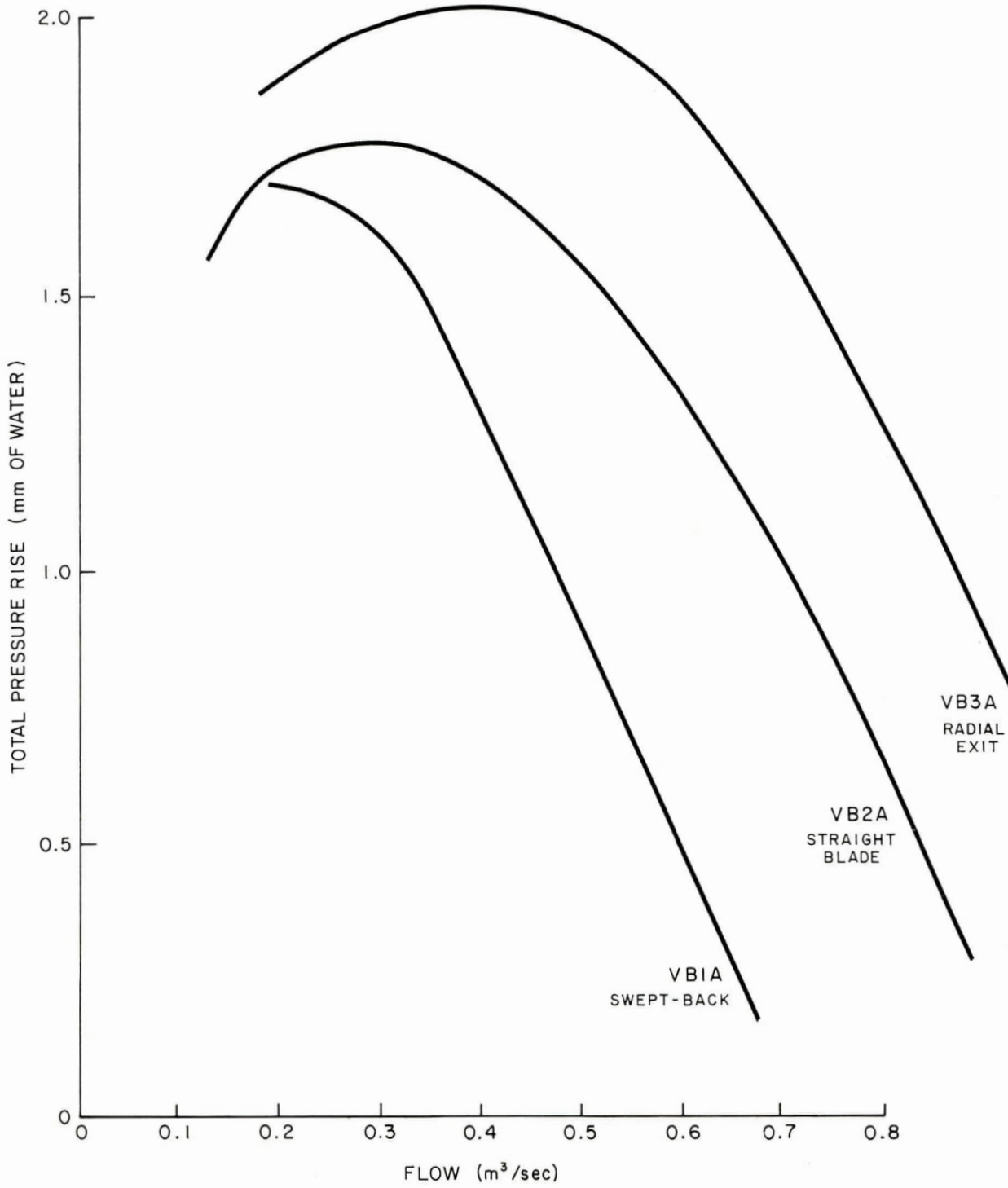

FIG. 6: PRESSURE RISE ~ FLOW CHARACTERISTICS (70 RPM)  
VARIANT (A) - AEROFOIL BLADES, SETS VB1, 2 & 3

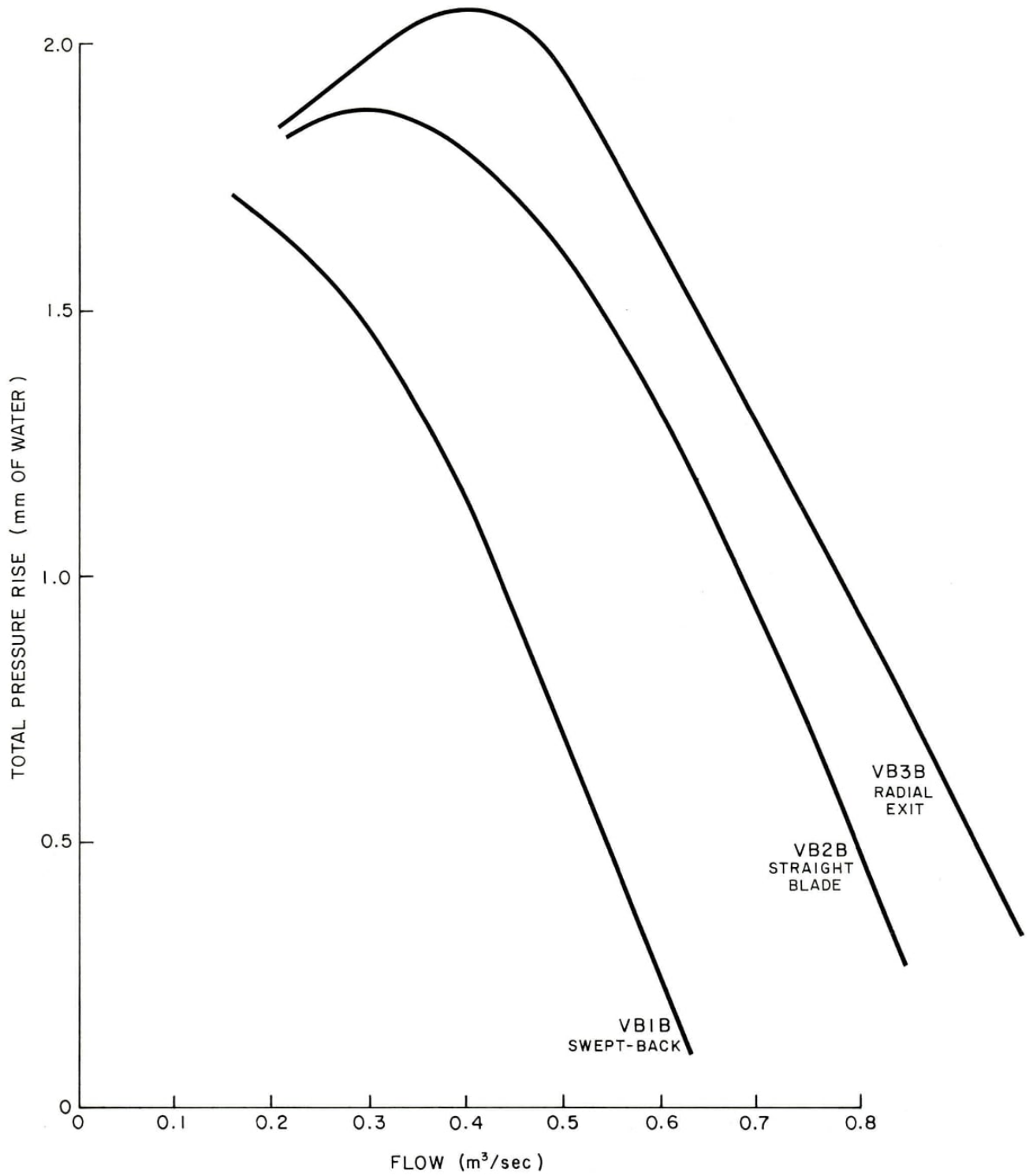

FIG. 7: PRESSURE RISE ~ FLOW CHARACTERISTICS (70 RPM)  
VARIANT (B) - SLOTTED AEROFOIL BLADES, SETS VB1, 2 & 3

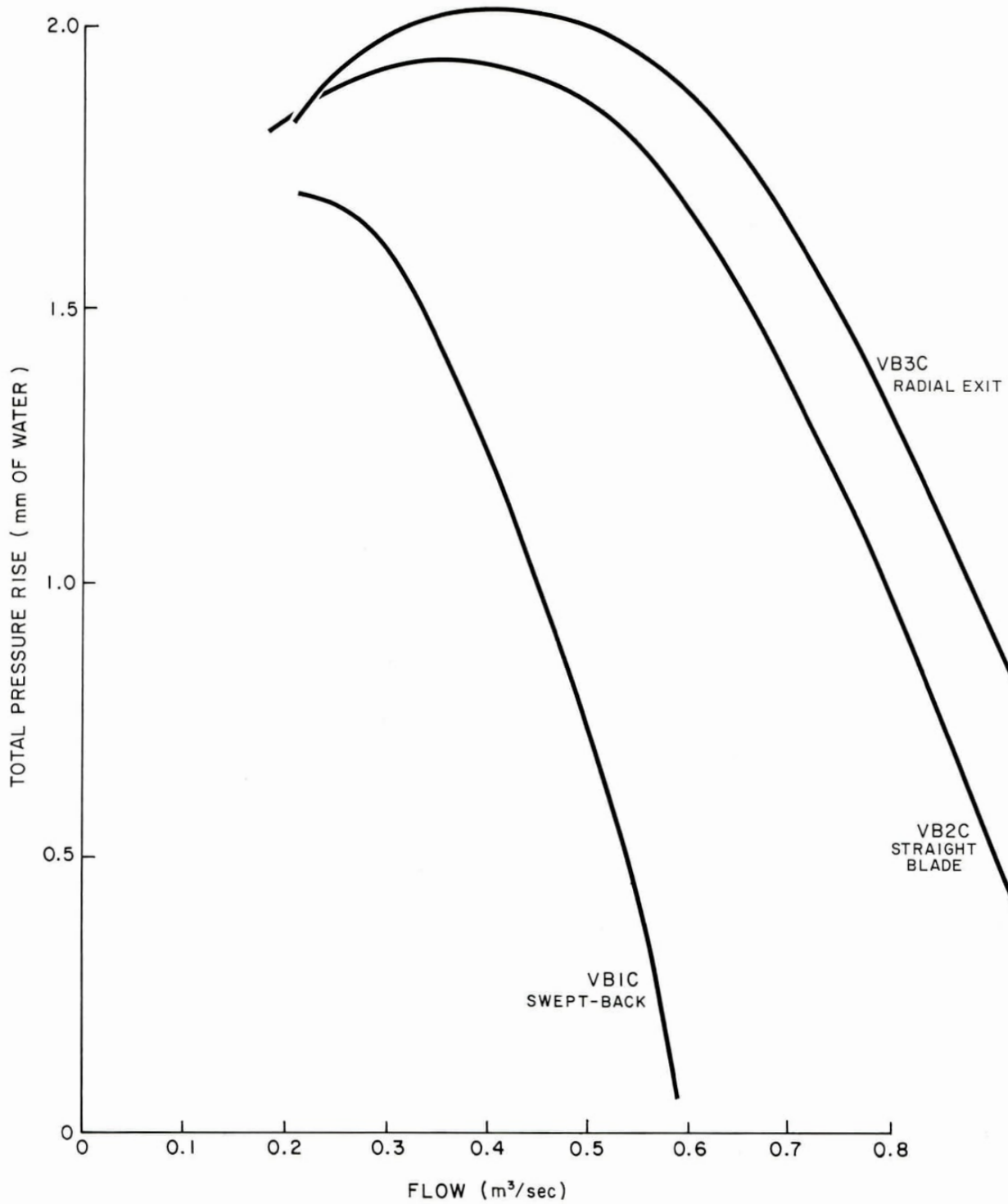

FIG. 8: PRESSURE RISE ~ FLOW CHARACTERISTICS (70 RPM)  
VARIANT © – THIN PLATE BLADES, SETS VB1, 2 & 3

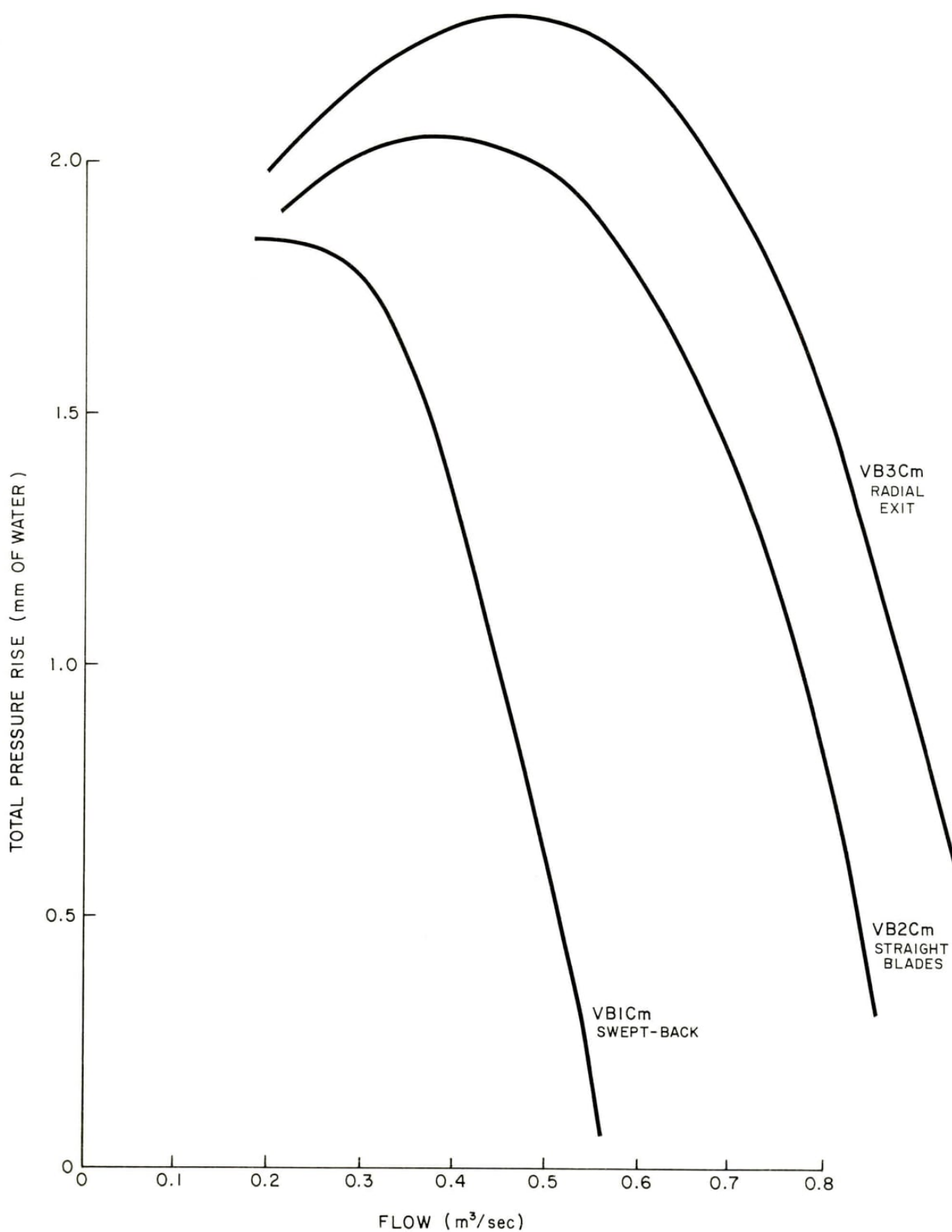

FIG. 9: PRESSURE RISE ~ FLOW CHARACTERISTICS (70 RPM)  
VARIANT  $\text{C}_m$  - THIN PLATE BLADES (CLOSELY SPACED), SETS VB1, 2 & 3

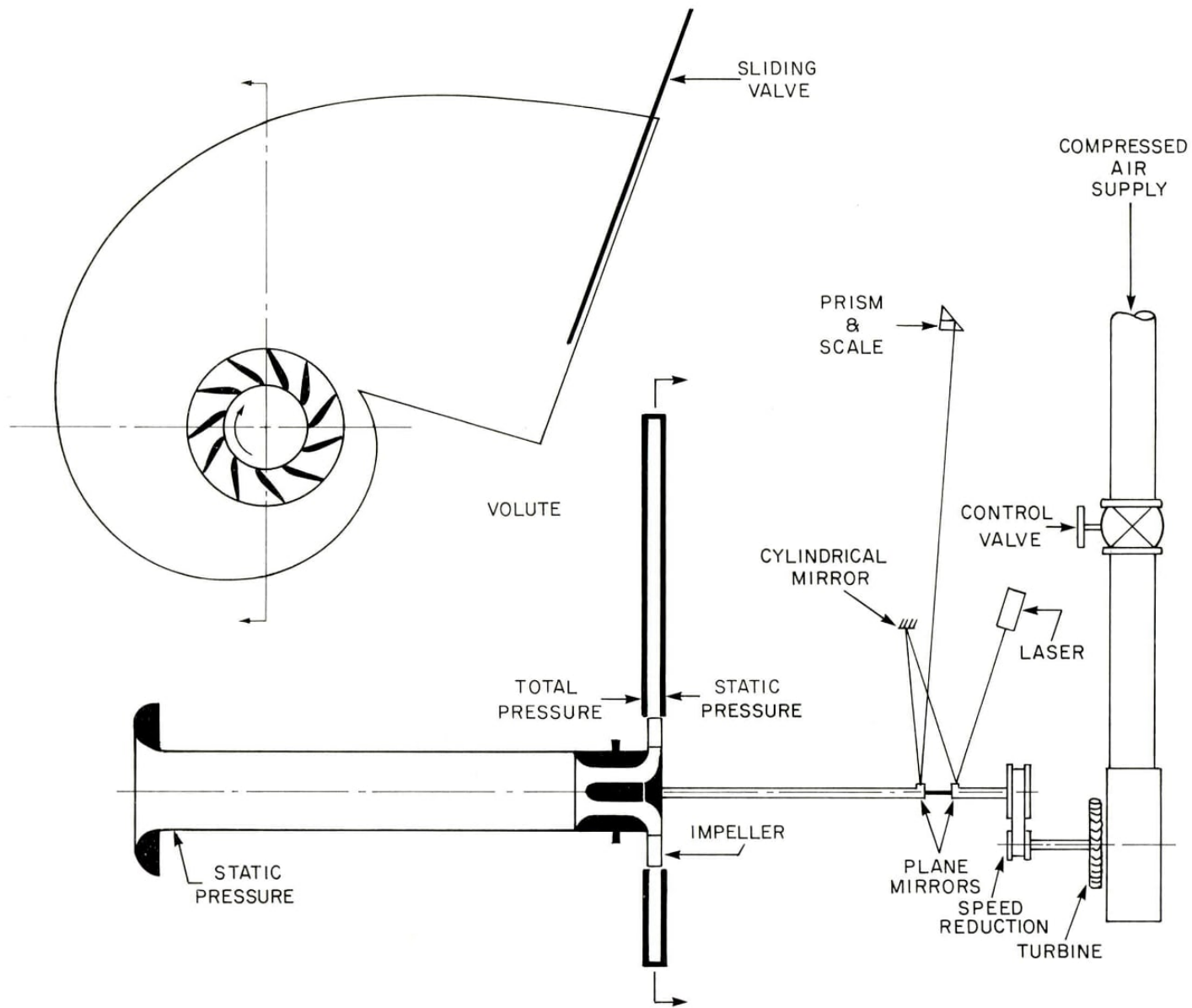

FIG. 10: DIAGRAM OF HIGH SPEED CENTRIFUGAL COMPRESSOR RIG

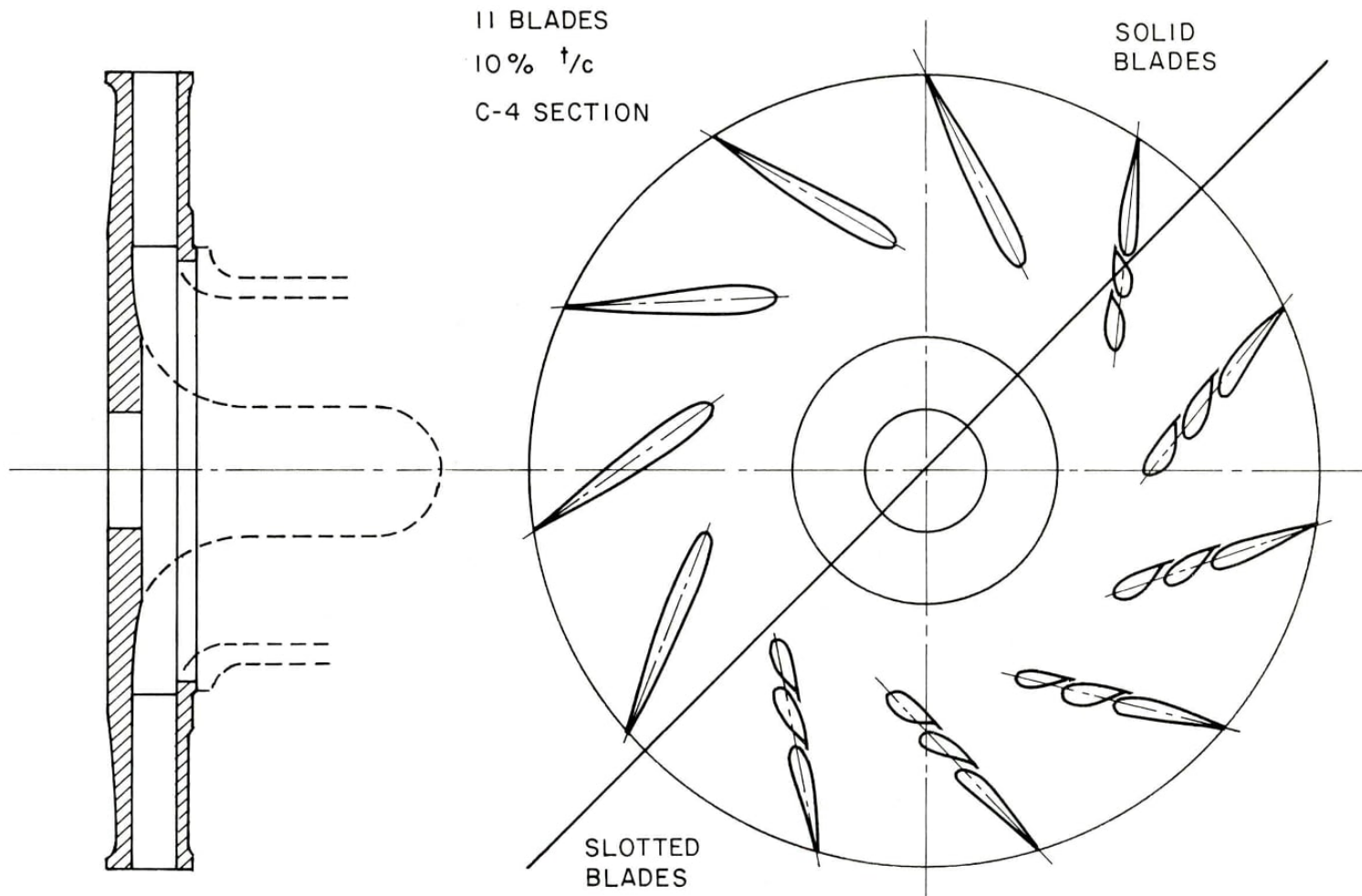

FIG. 11: SOLID AND SLOTTED BLADES

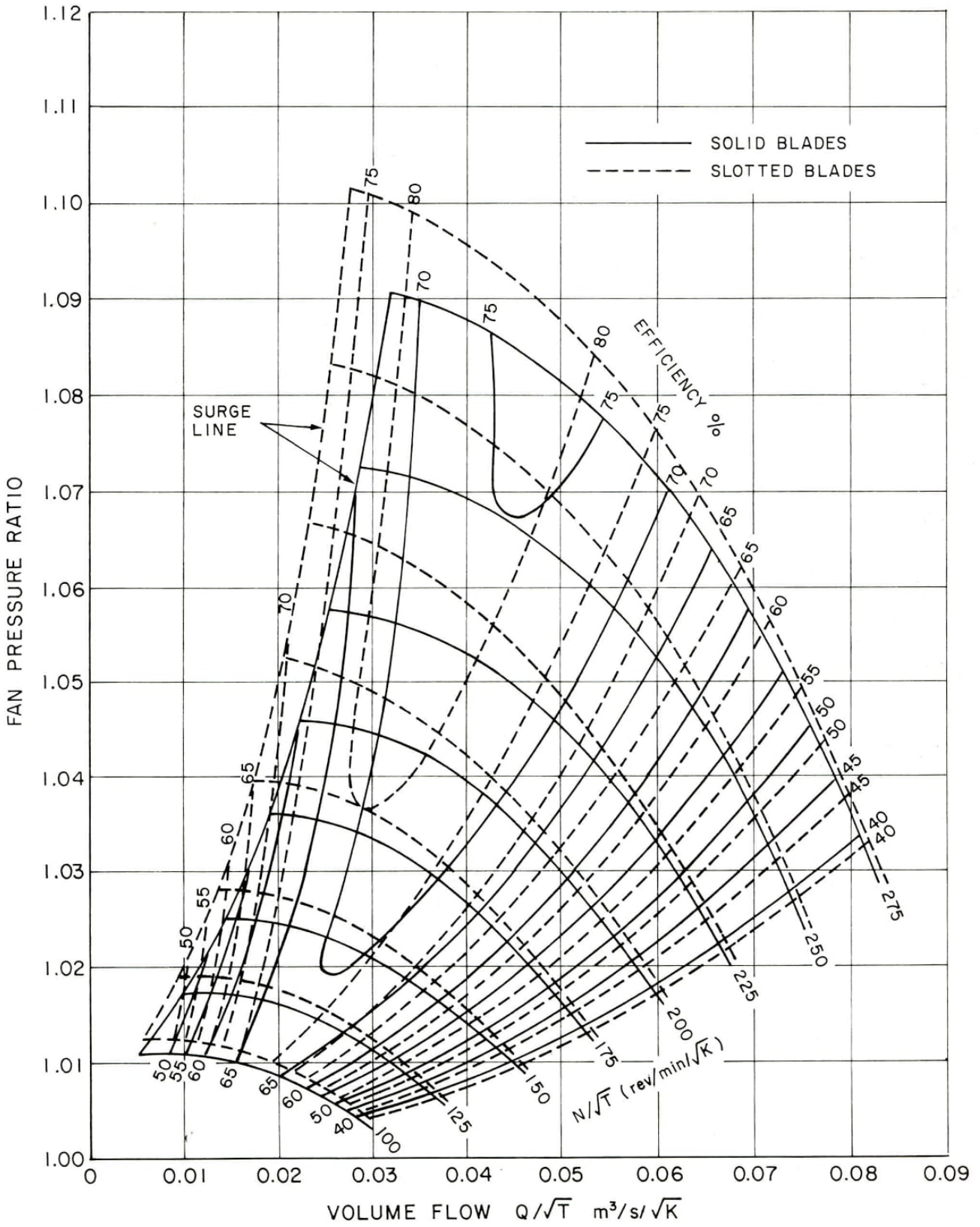

FIG. 12: FAN PERFORMANCE  
(HIGH SPEED RIG)

## APPENDIX A

### A.1 FLOW DETACHMENT IN IMPELLER CHANNELS, AND INITIAL EXPERIMENTS TO SELECT THE MOST PROMISING PREVENTIVE DEVICE

There are many methods of delaying the detachment of surface flow. Broadly speaking, detachment occurs in the impeller channel for three reasons.

Firstly, rapid local diffusion in the channel may produce too high a positive pressure gradient in the boundary layer, leading ultimately to reverse flow and detachment.

Secondly, the inertial forces of rotation may force the fluid to one side of the channel, detaching the flow from the suction side.

Thirdly, three-dimensional flow due to pressure gradients may upset the flow, in a manner analogous to the "secondary flow" well-known in axial compressor cascade theory.

Finally, excessive positive or negative incidence at the blade leading edge, due to operation far off the design point, may stall the blades. This factor is being neglected at present, and will be considered at a later stage.

The first factor, excessive diffusion rate, can be studied in a stationary diffuser, and is well understood.

The second factor can be simulated statically to some extent by bending the centreline of the channel in an arc, so that flow along the channel is affected by a centrifugal force transverse to the curved channel centreline. This permits very simple tests to be run statically for a preliminary assessment of various schemes.

Preliminary tests were therefore run on a number of possible schemes, using a cambered aerofoil in a two-dimensional tunnel, in which the two channel walls were simulated by the two surfaces of the aerofoil. This method allowed the examination of slots passing from one side of the "wall" to the other.

A most important criterion was that the schemes selected for further examination must be stable. That is to say, that they are intended for use in a practical compressor which will encounter changes of operating condition, and probably even surge. Under these circumstances, the device must be capable of accepting an initially disturbed airflow, and stabilizing it into the required flow pattern. A device which will only retain an initially good flow, but will break down once the flow has collapsed, would not be acceptable.

### A.2 INITIAL STATIC TESTS

Initial tests were run on a series of two-dimensional aerofoils of various cambers in the jet issuing from a 0.13 m × 0.13 m nozzle on a low speed blowing tunnel. The aerofoils were modified by the use of slots, vortex generators, a leading edge slat, and a deflector blade. At this stage of the investigation, devices with externally powered blowing or suction, or rotating leading edges, were not considered. This was simply because such systems would be complicated to install in an actual compressor, and it was thought proper to consider the simpler systems first.

All these tests were run at zero incidence, on aerofoils with increasing degrees of camber, and the effectiveness of the detachment-delaying devices judged on the basis of wool-tuft and smoke flow visualization.

Figure A-1 shows the smoke visualization of the flows around the aerofoils concerned. The first device to be tested was the simple slot, singly and with two in series. Figure A-1 shows selected photographs of the flow visualized with smoke, while Figure A-2 presents diagrams traced from photographs, showing these results for the three aerofoils tested, namely of 60°, 75°, and 90° circular arc camber. All were approximately of 10% t/c. C.4 section, and all tests were at 0° incidence. The performance, measured from these figures, is summarized below.

Camber	No Slots		One Slot		Two Slots	
	Deflection	Deviation	Deflection	Deviation	Deflection	Deviation
60°	46°	14°	46°	14°	51°	9°
75°	51°	24°	59°	16°	63°	12°
90°	66°	24°	68°	22°	74°	16°

This shows the reduction in deviation (or improvement in performance) due to the slots, particularly at high camber angles. It also shows that while two slots are better than one, the improvement is diminishing and suggests that two is probably the maximum effective number.

At this stage the slots were designed purely by eye, on the well-known engineering principle that “if it looks right, then it is right”. Smoke visualization showed that quite an appreciable quantity of air flowed through the slot from pressure side to suction side of the wing. At a later stage in the program it was necessary to vary the slot profile systematically, and relate this to performance and to total pressure loss in the aerofoil wake. This step was omitted in this first crude investigation.

#### A.2.1 Leading Edge Slat

As an extreme case of the slot, a leading edge slat of orthodox type was tested on the 90° camber aerofoil (Fig. A-3b). So far as could be seen, this slat, which formed a slot at the nose of the aerofoil, had no influence over the flow over the trailing 50% of the aerofoil. It might have shown to advantage at high positive incidence angles (the usual role of the leading edge slat), but this was not the aim of this experiment.

#### A.2.2 Deflector

A further extreme case was the use of a simple deflector. Figure A-3c shows the deflector tried. It was a 10% C.4 aerofoil of about 30° camber. It did indeed stick the flow to the convex surface of the main aerofoil, but was itself completely stalled over its convex surface. The associated losses and general flow disruption were obviously too bad for this scheme to be of any use in this connection.

#### A.2.3 Vortex Generators

Vortex generators were tried, in an attempt to get vortices to pull down a continuous supply of high energy air into the boundary layer, in the hope of keeping it attached.

On the basis of Gould’s use of aerofoil-type generators on the wings of an aircraft and a note by Schubauer and Spangenberg (Ref. 3), both aerofoil and wedge type vortex generators were made.

The aerofoil type (A-4b) thickened the boundary layer and wake very considerably, but did not appear to reduce the deviation; if anything the deviation increased by about 4° over the value with no device.

The wedge type was tested in two arrangements, (see Figs. A-4c and A-4d). Reference 3 shows that such wedges are effective vortex generators both with the apex up-wind (“Triangular Flow”)

and in the reverse direction ("Ramp"), although their other characteristics differ slightly in the two positions.

The "Ramp" position (Fig. A-4c) was tried first. While it did reduce the deviation a little more than the aerofoil vortex generators, it still thickened the wake very much, and was much less stable in operation. Disturbances were likely to detach the airstream from the convex surface of the blade.

The "Triangular Plow" type was then tried. It normally tripped the flow completely off the aerofoil, as shown in Figure A-4d. It was possible to force the flow back onto the blade, but it detached again at the slightest provocation.

### A.3 STABILITY

This raised the question of the stability of these devices in an acute manner. At this early stage in the program an extremely crude test was devised, to separate devices into Stable, Neutral, and Unstable groups. This was a vital step, since as previously explained the aim of the program was to select devices which would perform reliably in a practical compressor, and which could reorganize the chaotic flow after a condition change or even a surge.

To make the test, the flow was set up with smoke to make it visible. If it was attached to the aerofoil, one hand was put into the tunnel like a scoop, to detach the flow by main force. When the hand was removed, if the flow promptly reattached, the configuration was considered "Stable".

If the flow refused to attach in the first place or detached while running, the hand was put in the other way and the flow forced down onto the blade. When the hand was removed, if the flow immediately detached again, it was judged "Unstable".

If the flow remained whichever way it was pushed, after the hand was withdrawn, it was classed as "Neutral".

On this showing, the Vortex Generators were Neutral, except the Triangular Plow, which was completely Unstable. The one and two slot configurations, however, were all completely Stable.

### A.4 CONCLUSIONS

The first phase of the program therefore closed with the decision that the Vortex Generators, L.E. Slats and Deflector Vanes were unsuitable for the requirement. Attention was therefore concentrated on the use of slotted blades, which appeared to show promise of preventing detachment of flow from the suction wall of the centrifugal compressor channel.

A. UNMODIFIED AEROFOIL

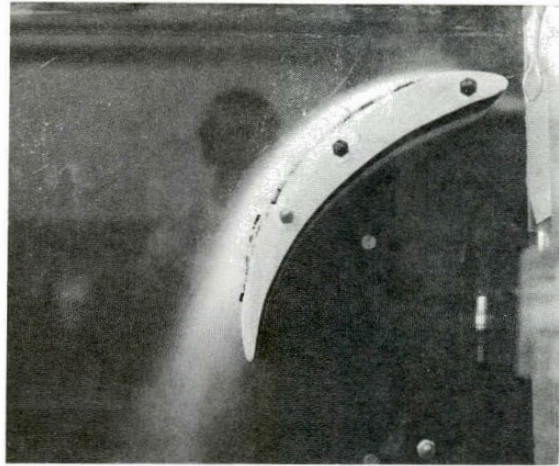

B. SAME AEROFOIL WITH TWO SLOTS

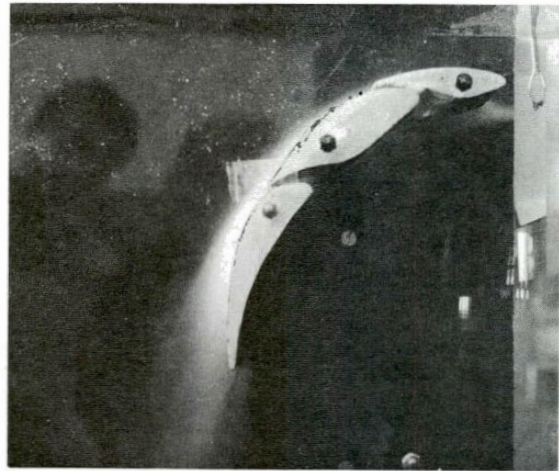

C. SAME AEROFOIL, WITH ROW OF "TRIANGULAR FLOW" VORTEX GENERATORS (FLOW COMPLETELY DETACHED)

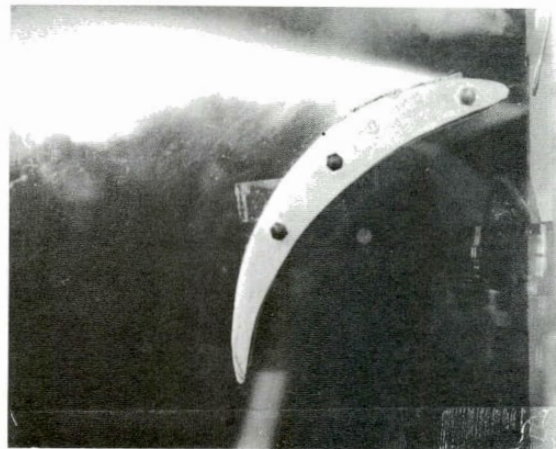

FIG. A-1: STATIC TESTS – SMOKE VISUALIZATION OF FLOW  
(90° CAMBERED AEROFOIL)

90° CAMBER AEROFOIL

75° CAMBER AEROFOIL

60° CAMBER AEROFOIL

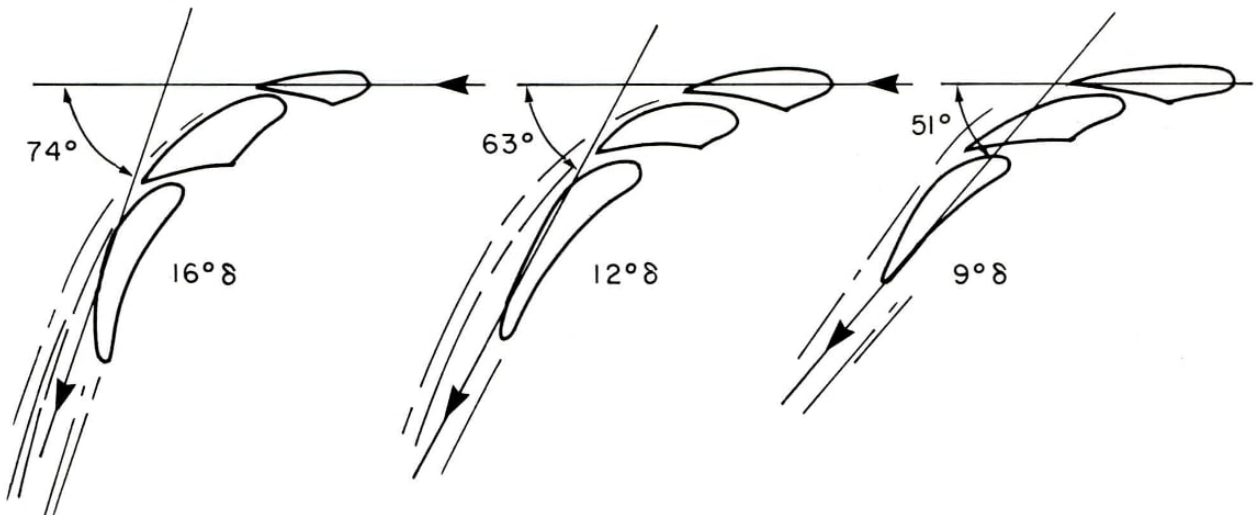
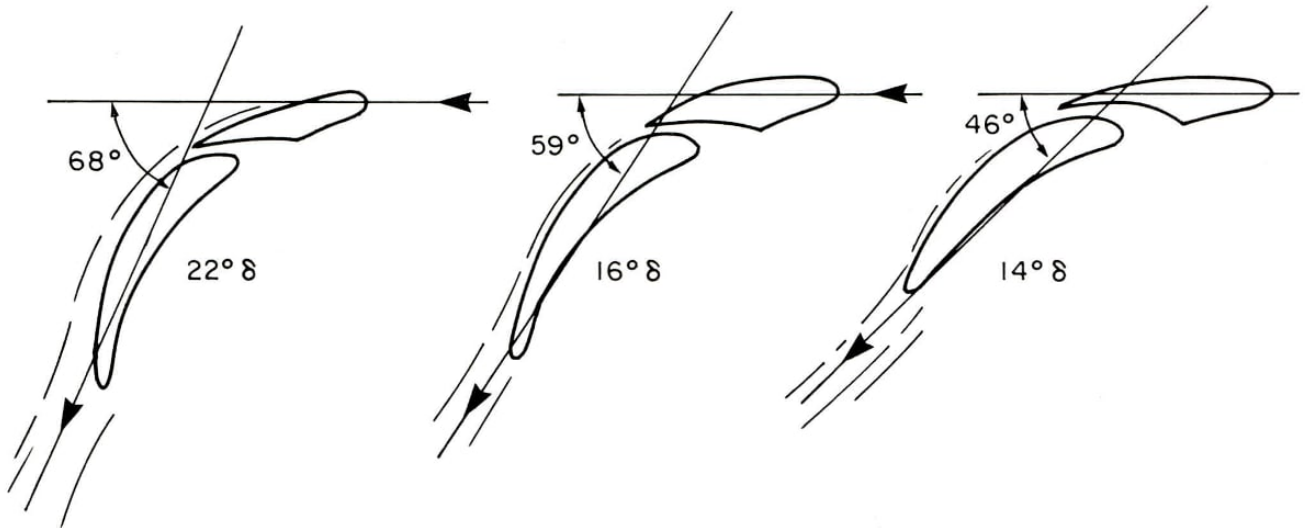
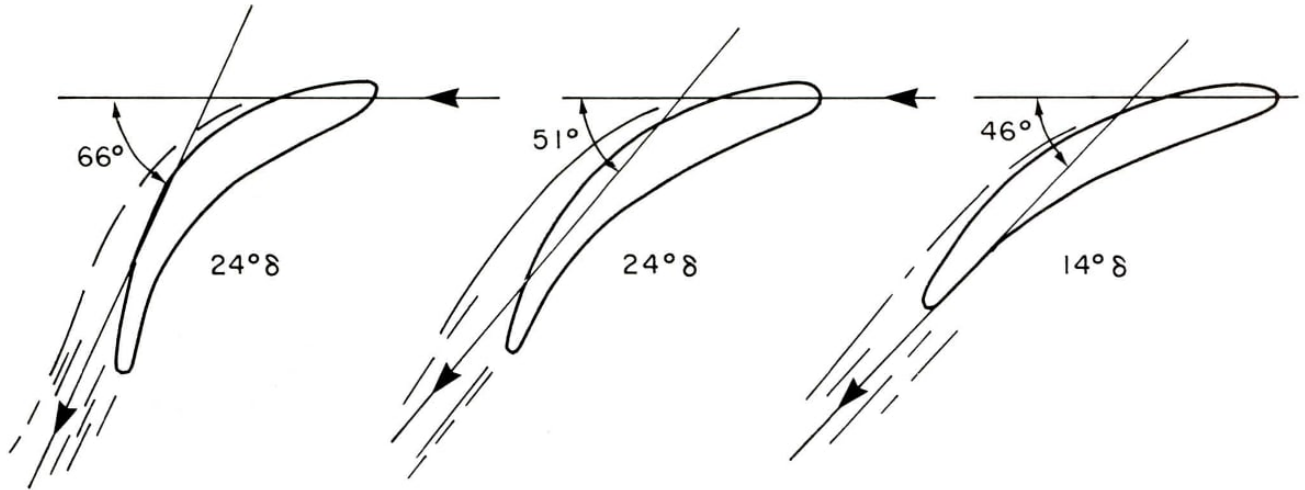
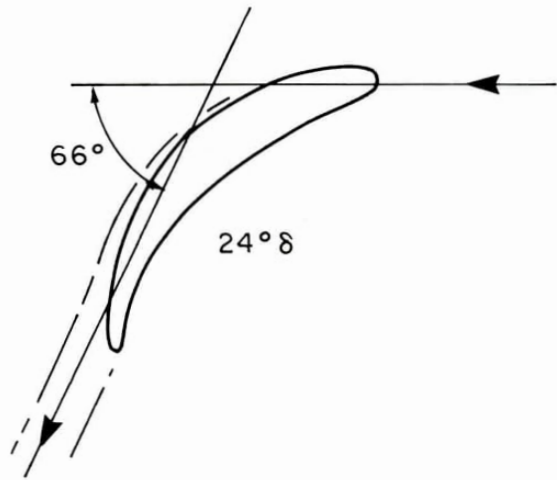

FIG. A-2: STATIC TESTS  
(VARIOUS SLOTTED BLADES)

90° CAMBER AEROFOIL

A. UNMODIFIED AEROFOIL



B. LEADING EDGE SLAT

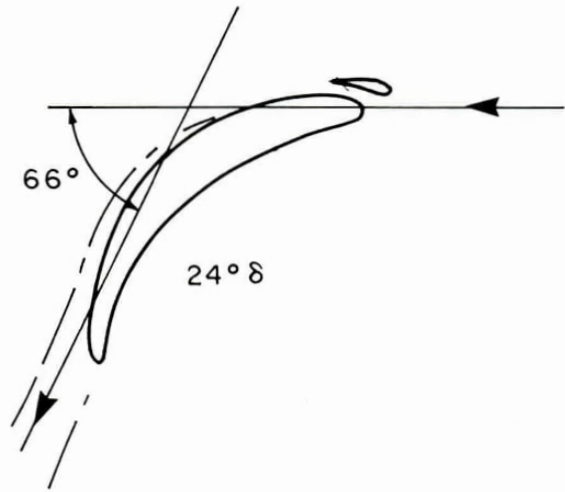

C. DEFLECTOR

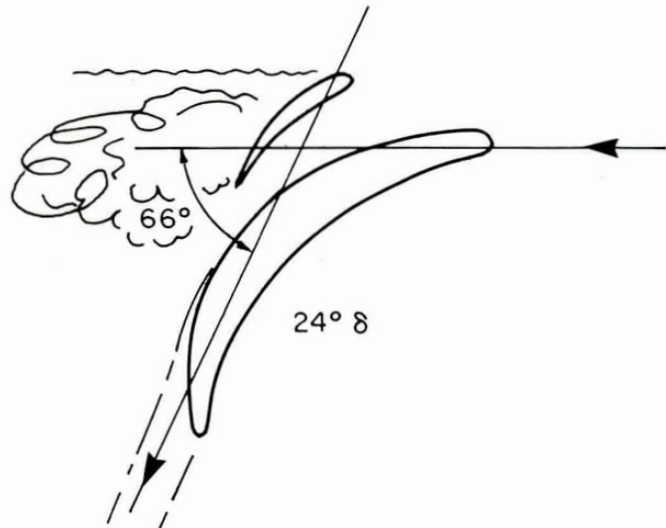
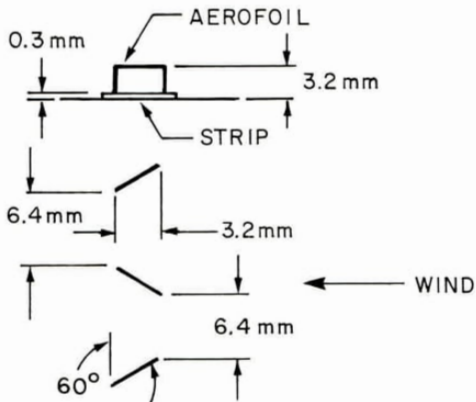

FIG. A-3: STATIC TESTS  
(SLAT AND DEFLECTOR)

90° CAMBER AEROFOIL

A. UNMODIFIED AEROFOIL

B. AEROFOIL VORTEX GENERATORS



C. "RAMP" VORTEX GENERATORS

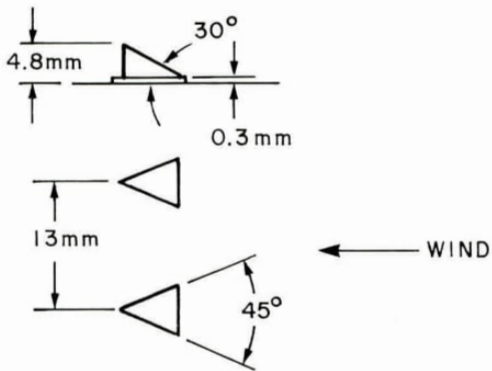

D. "TRIANGULAR PLOW" VORTEX GENERATORS

( SAME STRIP OF WEDGES REVERSED )

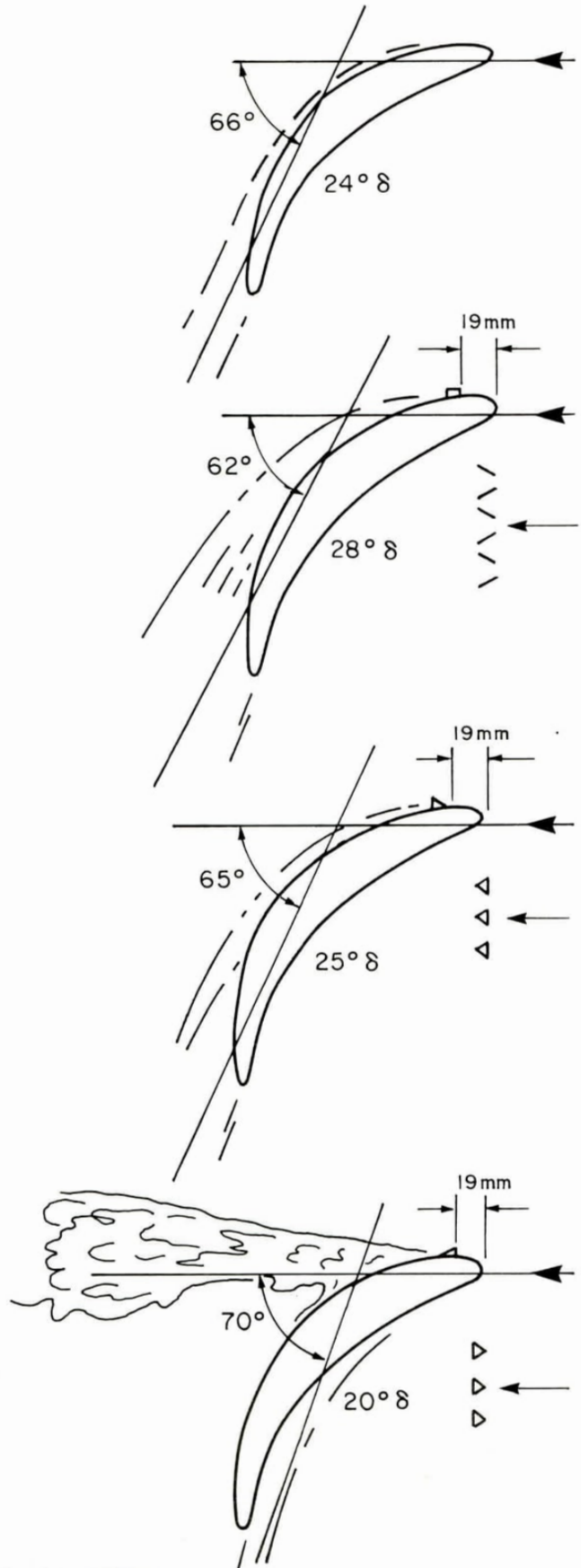

FIG. A-4: STATIC TESTS  
(VORTEX GENERATORS)

APPENDIX B

B.1 INDEX OF BLADES TESTED

There were three sets of blading, Nos. 1, 2, and 3. Each of these sets was first tested plain, and then tested again after two slots had been added to each blade. The unslotted and slotted blades were identified as "A" and "B" respectively of each set 1, 2, or 3.

A further variant of each set was tested (identified as "C") in which the blade consisted of a simple 5 mm thick sheet, laid on the same camberline as the "A" and "B" variants of each set 1, 2, or 3. This "C" variant was also tested with a greater number of blades in the ring, to alter the solidity of the ring (identified as "Cm" variant).

The "C" variant originated in an earlier series of tests (Ref. 2), and differs slightly from the "A" and "B" variants in that the blade leading edge pitch circle diameter is a little smaller (0.802 m instead of 0.840 m diameter), but it seems unlikely that this would invalidate the comparison.

INDEX OF BLADES TESTED

BLADE IDENTITY VB SERIES	VB 1				VB 2				VB 3			
	A	B	C	Cm	A	B	C	Cm	A	B	C	Cm
Impeller Blade L.E. Pitch Circle Diam.	0.838 m		0.803 m		0.838 m		0.803 m		0.838 m		0.803 m	
Impeller Blade T.E. Pitch Circle Diam.	1.483 m				1.483 m				1.483 m			
Blade Inlet Angle (to Tangential Direction)	35°		30°		35°				35°			
Blade Outlet Angle (to Tangential Direction)	30°		26°		62.5°				90° Radial			
Aerofoil Section	C-4		Thin Plate		C-4		Thin Plate		C-4		Thin Plate	
Aerofoil Section Max. Thickness/Chord	10%		1%		10%		1.5%		10%		2.0%	
Blade Height	0.082 m				0.082 m				0.082 m			
Camberline	Circular Arc				Straight				Circular Arc			
No. of Blades	8	8	8	14	11	11	11	19	13	13	13	23

All experiments in this phase carried out at 70 RPM, with atmospheric inlet. Throttling to vary flow applied at delivery only. Other rotational speeds were tested and reported in References 4 and 5.

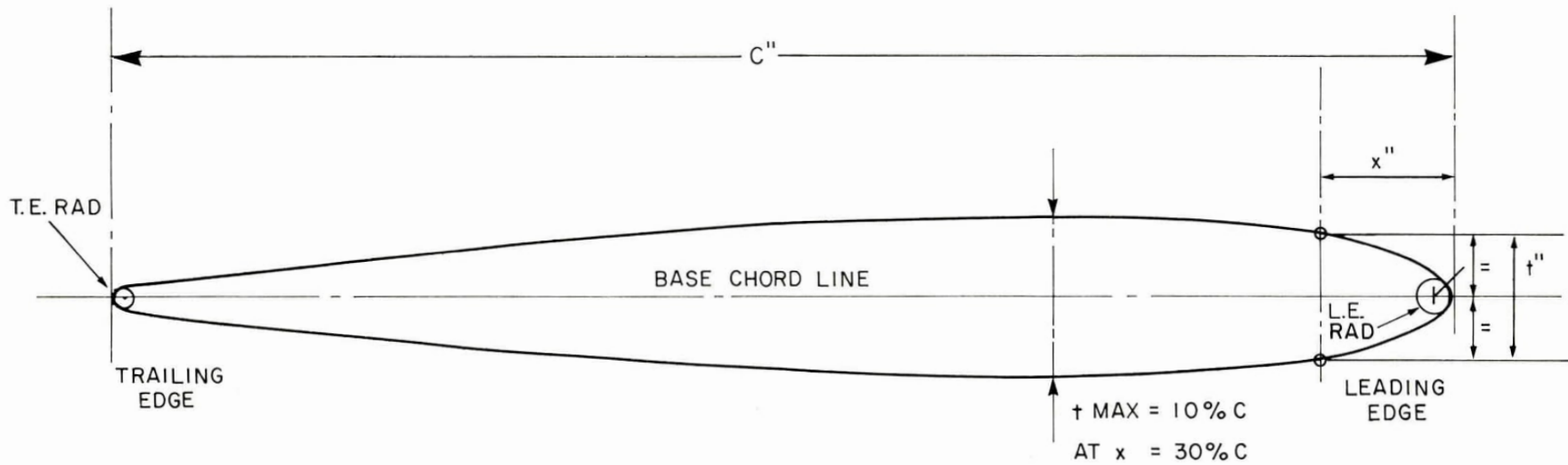

ORDINATES FOR C-4 AEROFOIL WITH  $t/c_{MAX} = 10\%$

	L.E.														T.E.	
$\frac{x}{c} \%$	0	2.5	5	7.5	10	20	30	40	50	60	70	80	90	100	L.E. RAD = 1.4% C	
$\frac{y}{c} \%$	0	4.54	6.17	7.25	8.04	9.67	10.00	9.78	9.14	8.11	6.75	5.08	3.20	0	T.E. RAD = 0.70% C	

FIG. B-1: C-4 AEROFOIL DATA

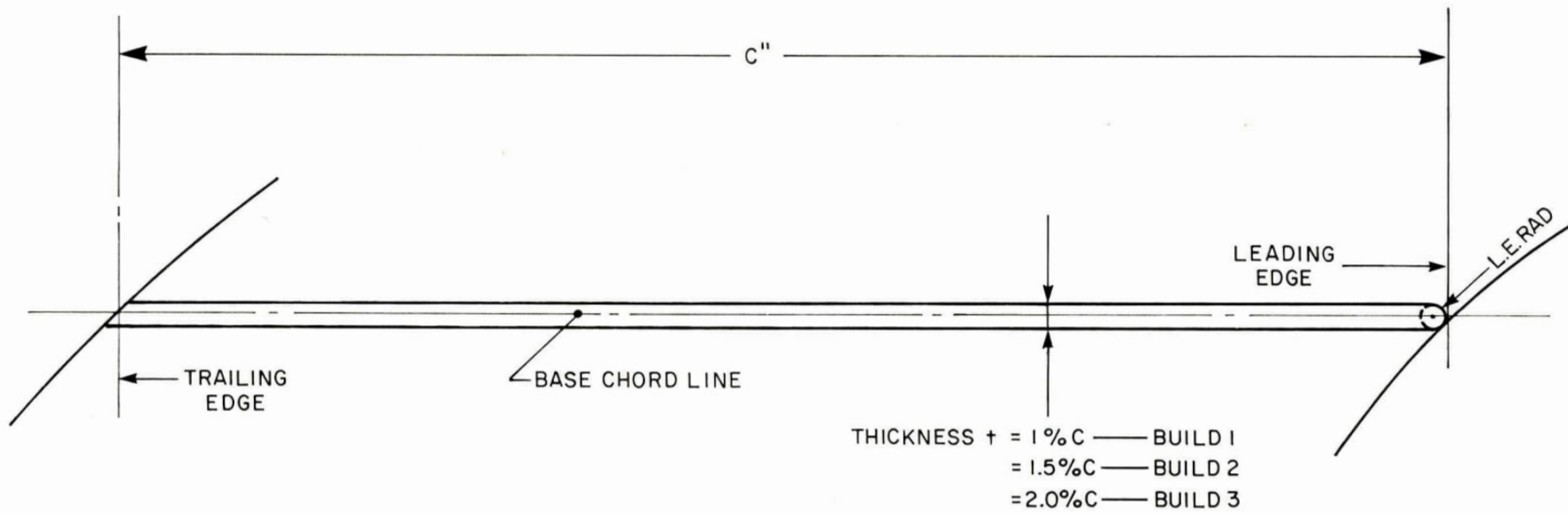

FIG. B-2: THIN-PLATE BLADE DATA

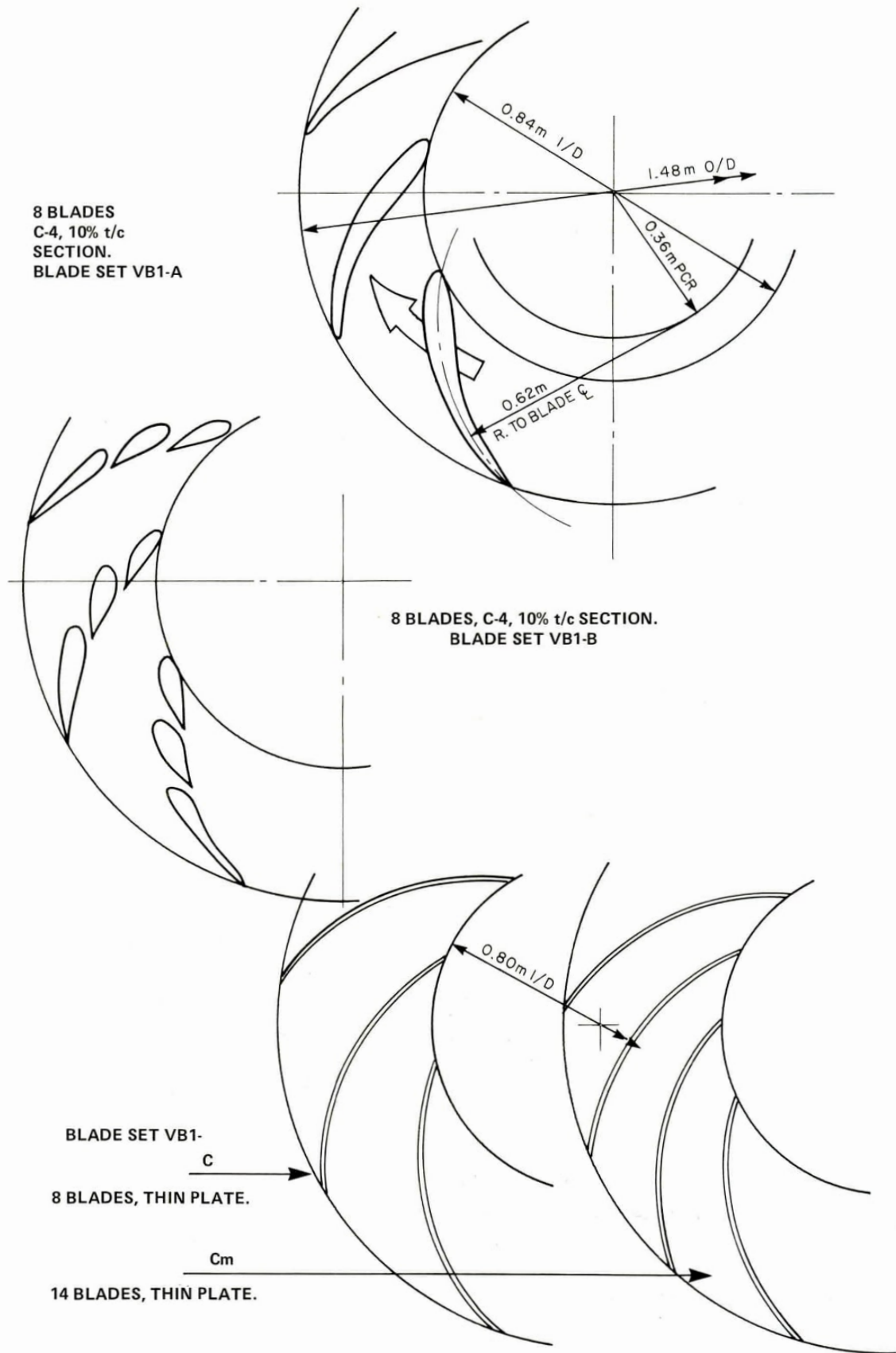

FIG. B-3: BLADE SETS VB1-A, B, C, AND Cm

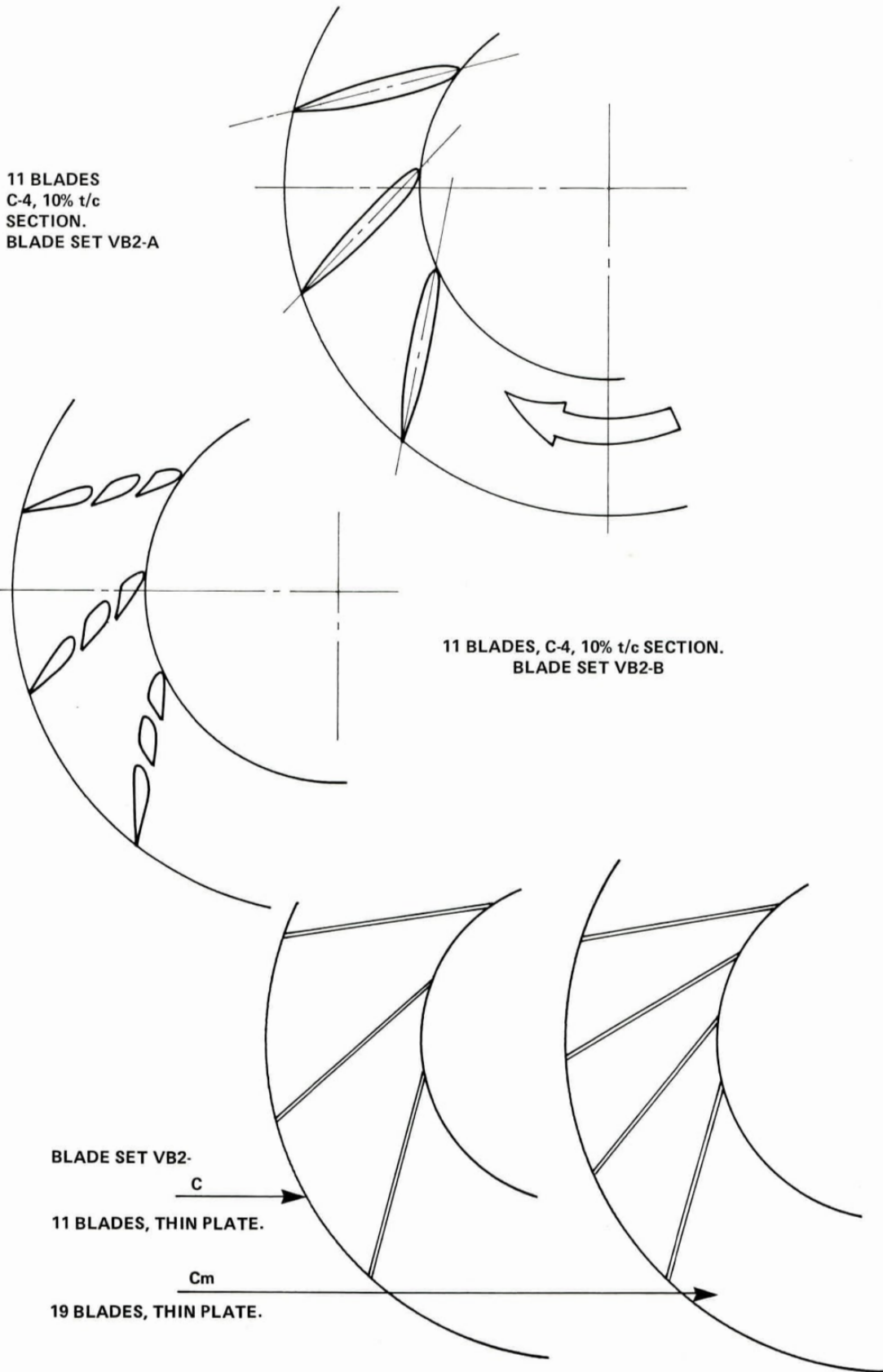
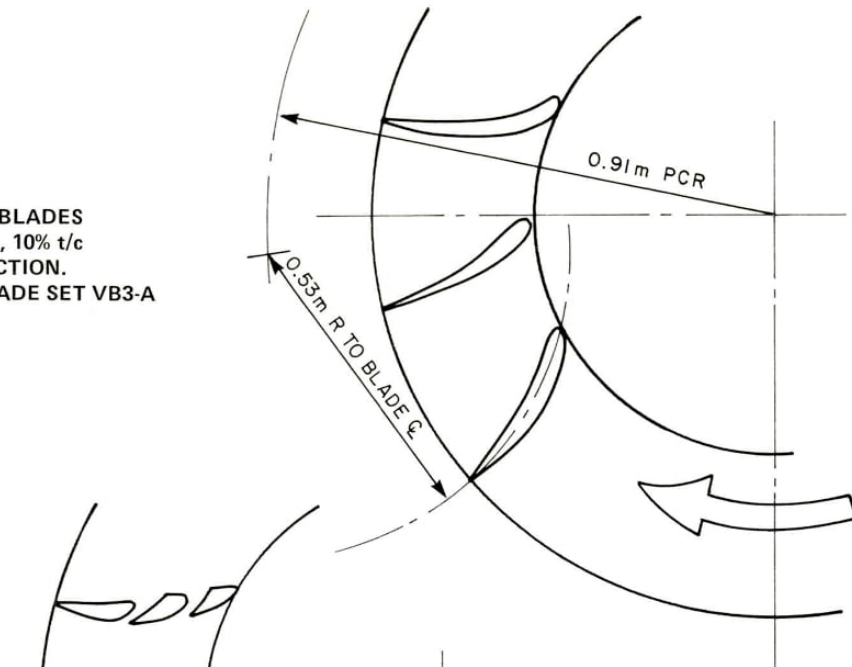
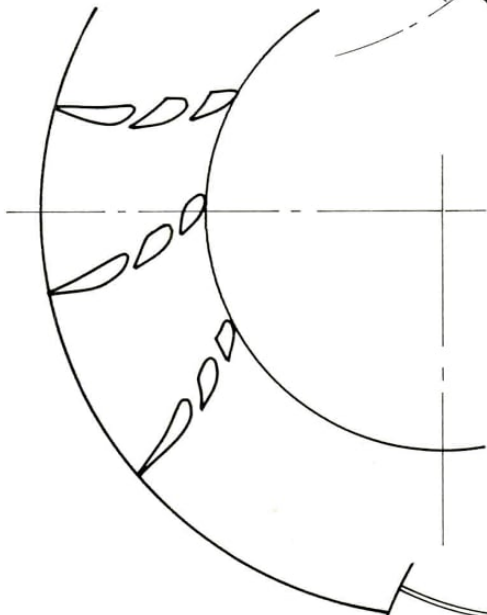

FIG. B-4: BLADE SETS VB2-A, B, C, AND Cm

13 BLADES  
C-4, 10% t/c  
SECTION.  
BLADE SET VB3-A



13 BLADES, C-4, 10% t/c SECTION.  
BLADE SET VB3-B



BLADE SET VB3-

C

13 BLADES, THIN PLATE.

C<sub>m</sub>

23 BLADES, THIN PLATE.

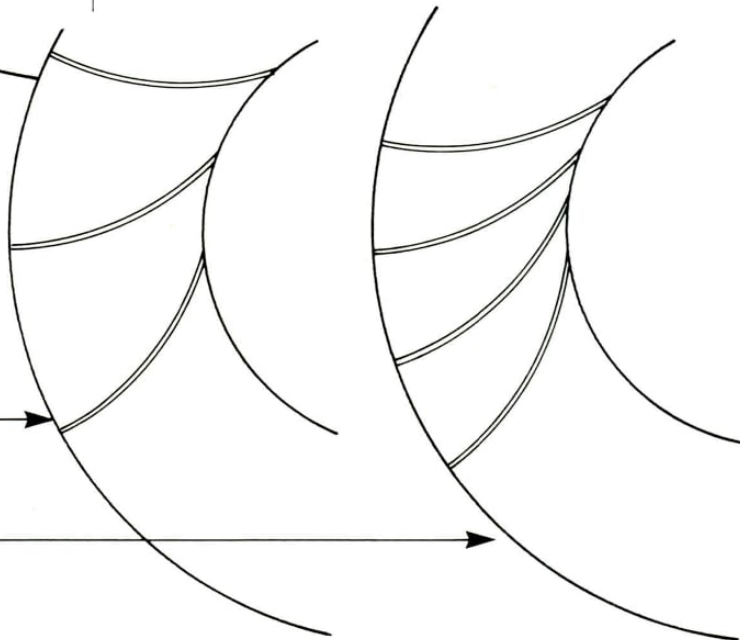

FIG. B-5: BLADE SETS VB3-A, B, C, AND C<sub>m</sub>

## APPENDIX C

### DISCUSSION OF SLOTS IN THE BLADES

#### C.1 DESCRIPTION OF BLADES

All the "aerofoil" blades tested were of C-4 Section with max. thickness (at 30% C) equal to 10% C. The blades were therefore orthodox axial compressor aerofoils.

#### C.2 DESCRIPTION OF SLOTS

Four rules were proposed for the design of the slots as follows:

- (i) The slot must inhale with minimum loss and disturbance from flow parallel to the blade pressure surface.
- (ii) The radius of curvature of the slot centreline must be kept as large as possible, and the rate of change of area shall be roughly constant through the slot.
- (iii) The slot must eject flow as nearly parallel to the blade suction surface as possible, with as little disturbance as possible.
- (iv) Total pressure loss in the slot must be a minimum.

Conditions 1, 2, and 3, control the slot centreline geometry. Ideally, it should be formed by two circular arcs of equal radii. In practice it is made as near to this as possible (see Fig. C-1).

These slot centreline radii are controlled by the aerofoil thickness, the required area ratio ( $A_1/A_2$ ) through the slot, and the points a and i on the surfaces, where flow is to enter and leave. These points are governed by the flow field round the aerofoil, and were determined experimentally. They are defined by the percentage of chord aft of the leading edge ( $\ell_1$  and  $\ell_2$ ,  $a'$  and  $i'$  on the chord line). Condition 4 is complex. Ideally, the slot should admit air at the local velocity near the slot inlet, and accelerate it at a reasonably constant rate, so that it leaves the slot at the corresponding local velocity in the region of the slot exit, assuming ideal flow around the aerofoil. If a flow quantity through the slot is chosen, and the flow field round the aerofoil specified, the slot profile can then be defined.

In point of fact, experiments gave sufficient indication of the size of slot required to give an effective flow, without letting too much of the total airflow "blow through the blades". Also, since the blade has to operate over a range of angles of incidence, which means a range of different velocity distributions round the blade, the degree of acceleration from slot inlet to outlet must be some compromise selected to cover a range of values. It was found that an Area Ratio  $A_1/A_2$  of around 5.5 produced satisfactory results, with a Flap Gap (see below) of from 2.0% to 2.5%.

Finally, the slot inlet lip is faired into the aerofoil pressure surface with radius to avoid detachment either from the slot wall or off the aerofoil surface downstream of the slot lip, as the incidence and local flow change.

The points on pressure and suction surfaces where the slot enters and leaves were initially chosen from inspection of boundary layer detachment points visualized by smoke; from then on the effects of slot shift, different numbers of slots, etc., were investigated in the experimental program.

The slots used were designed in a very empirical manner as the above rules were evolved. They are analysed in retrospect in Figures 9 and 10 on the basis of these rules.

### C.3 COMPARISON WITH FOSTER'S PAPER (AIAA 71-96) (Ref. 4)

A paper by Foster of RAE, "The Flow round wing sections with high-lift devices", describing experiments on slots in wings became available in January 1971. It discussed work directly comparable to the investigation described here, although with much lower camber and deflection angles. Foster uses "Flap Gap"  $\equiv$  (slot throat width/chord) % as the parameter describing his geometries, and his results show a strong optimum over the range from 1.5% to 2.5%, with a peak at about 2.2%. It was observed with considerable interest that the two slots in the most successful arrangement of the program reported here have "Flap Gap" values of 2.42% and 2.06%.

The flow visualizations carried out in this program also agree with Foster's conclusion, based on wake pressure surveys, (Foster's Fig. 7) which is that: "The optimum gap is at, or very near to, the smallest gap at which the boundary layer on the flap and the boundary layer on the wing lower surface are just separate". In other words, the gap must be wide enough to allow a jet of free-stream air from the pressure side of the aerofoil to be transferred onto the suction side downstream of the slot, so that the suction side is insulated from the low energy boundary layer which has built up upstream of the slot.

Such qualitative and quantitative agreement between results derived from very different sources was extremely encouraging. It also suggested that provided this conclusion was realized, the system should not be sensitive to Reynolds Number changes.

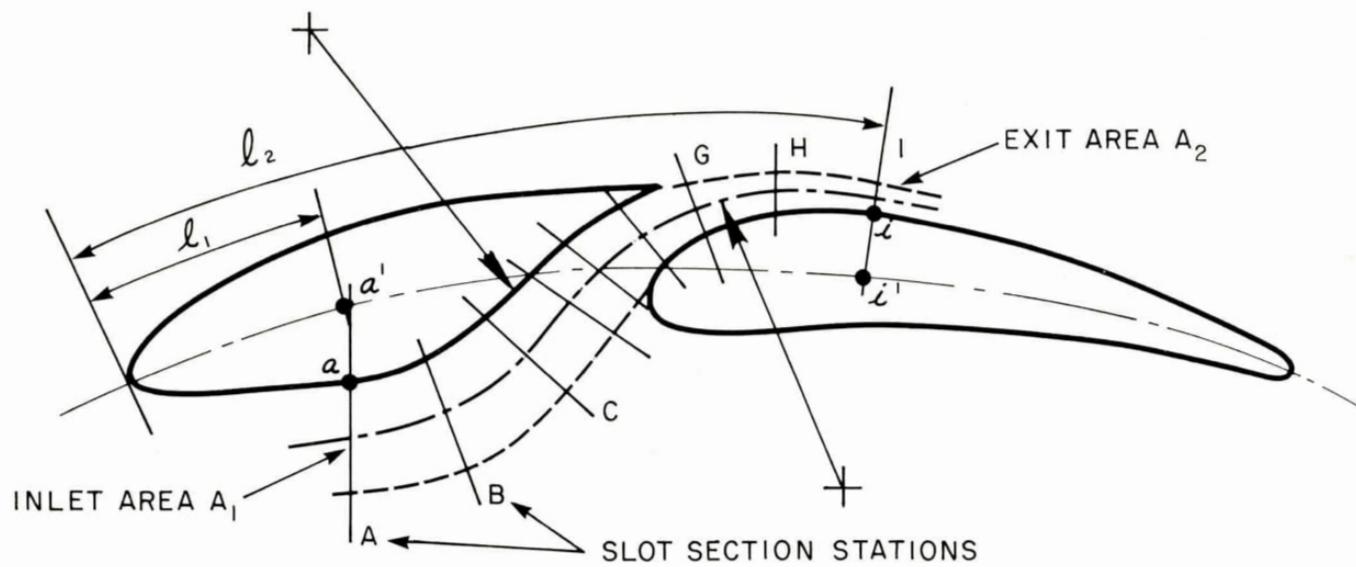
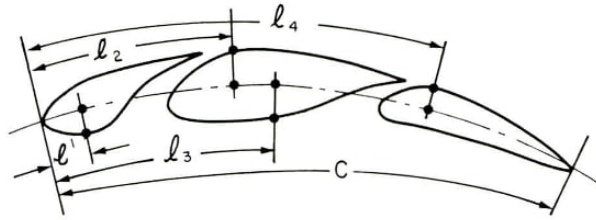
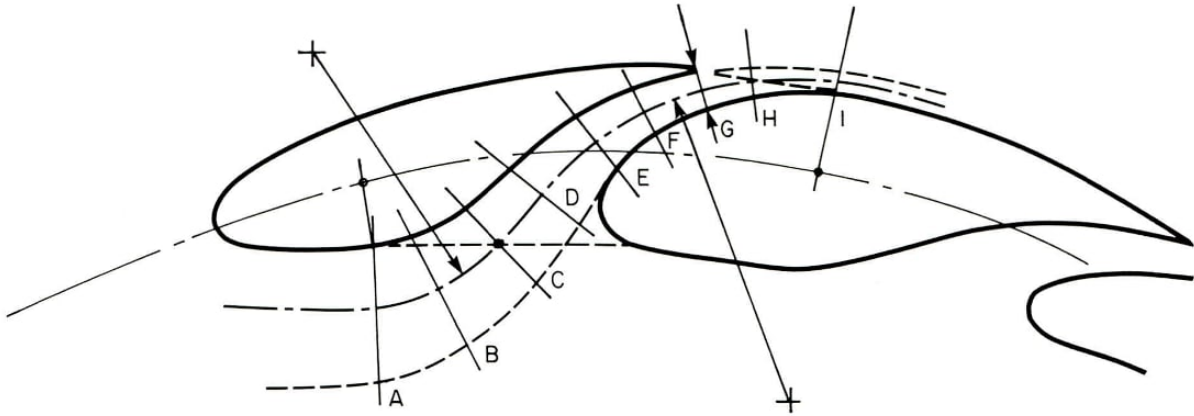

FIG. C-1: SLOT DESCRIPTIVE NOMENCLATURE



SLOT 1	$l_1 = 10.7\% C$	$l_2 = 42.5\% C$
	AREA RATIO = 5.3	FLAP GAP = 2.42%
SLOT 2	$l_3 = 40.0\% C$	$l_4 = 77.0\% C$
	AREA RATIO = 5.7	FLAP GAP = 2.06%



SLOT E1

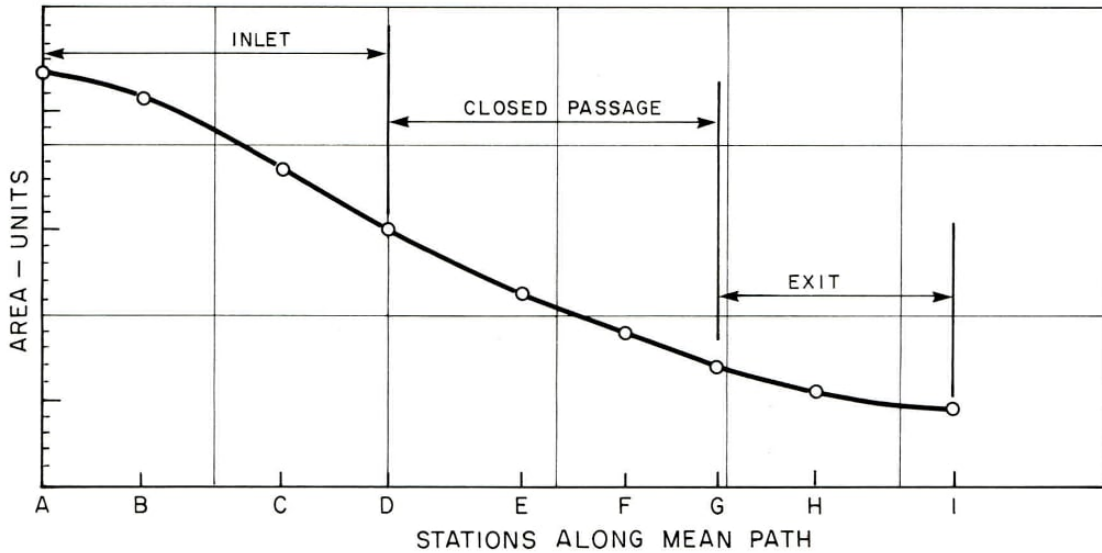
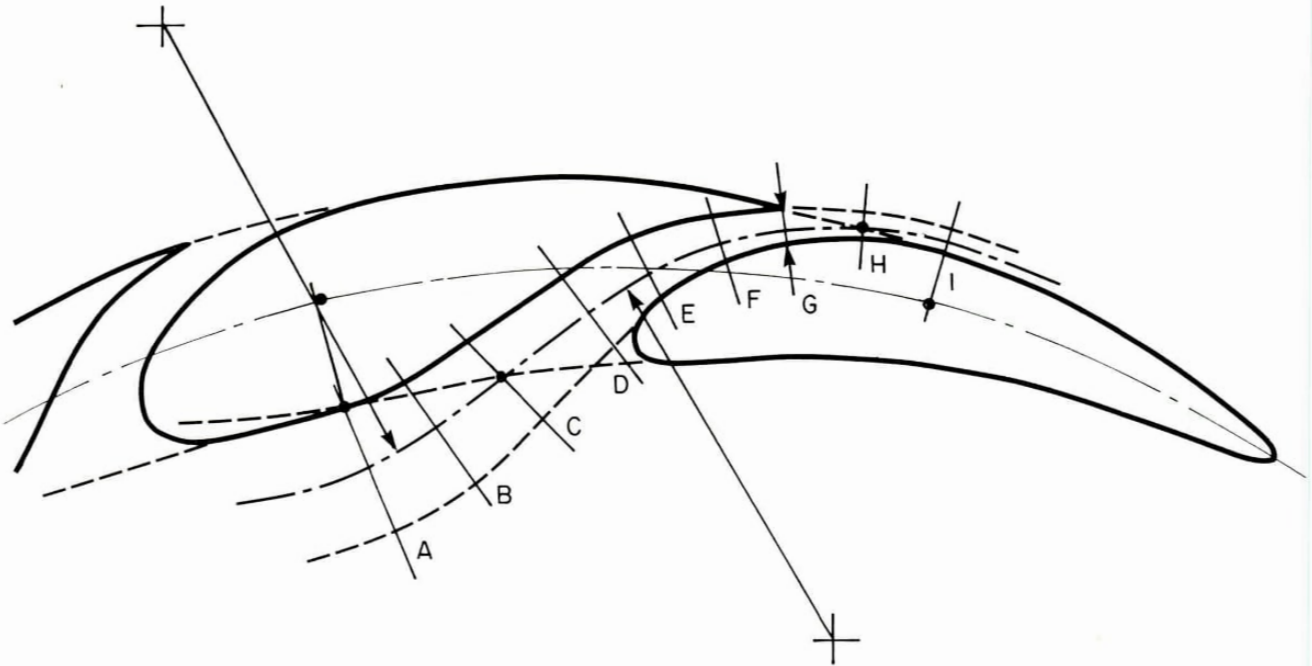

FIG. C-2: BLADE "E" - TWO SLOTS



SLOT E2

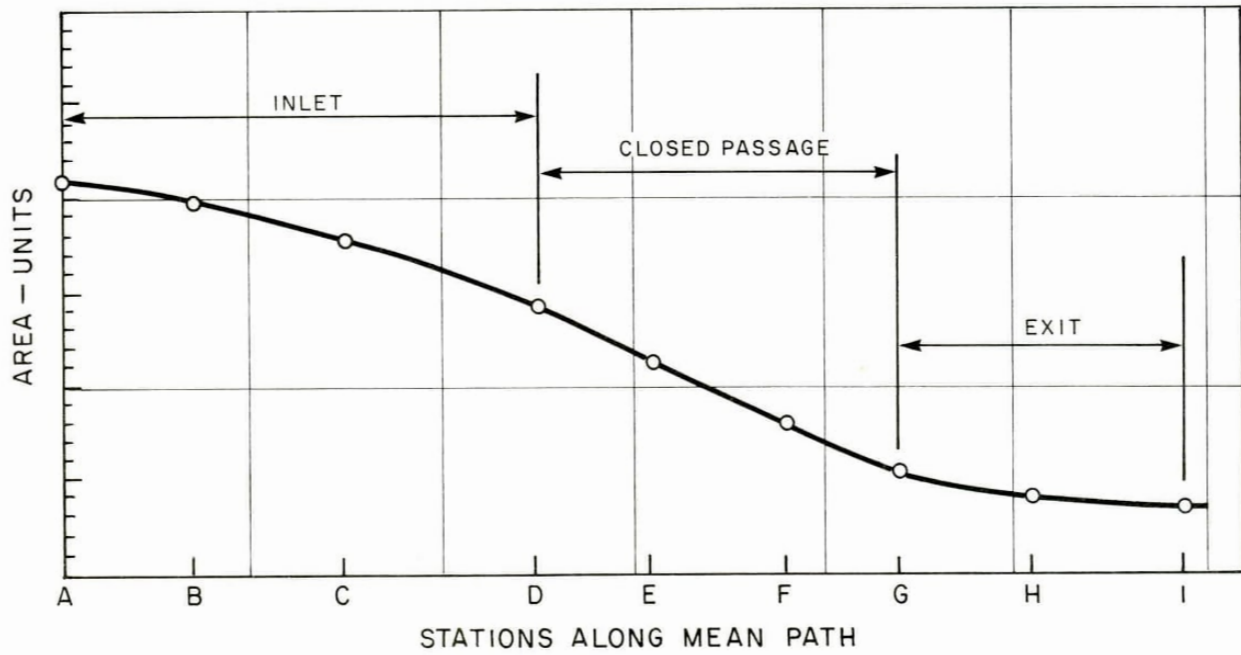

FIG. C-3: BLADE "E" - TWO SLOTS

NRC, DME ME-248  
National Research Council Canada. Division of Mechanical Engineering.

THE INFLUENCE OF BLADE PROFILE AND SLOTS ON THE  
PERFORMANCE OF A CENTRIFUGAL IMPELLER.

Fowler, H.S. January 1980. 45 pp. (incl. figures and appendices).

As part of the program of studies on centrifugal impellers, the problem of instability at low flows was investigated. The major cause was found to be flow detachment from the impeller vanes.

Slotted blades were found to be the most effective means of delaying this detachment, and extending the working range of the blower.

Low speed studies were confirmed by a test program on a high speed machine, where it was demonstrated that the improved flow range was accompanied by a general increase of efficiency.

The design and placement of the slots is discussed.

UNCLASSIFIED

1. Centrifugal compressors.
2. Impellers.

- I. Fowler, H.S.
- II. NRC, DME ME-248

NRC, DME ME-248  
National Research Council Canada. Division of Mechanical Engineering.

THE INFLUENCE OF BLADE PROFILE AND SLOTS ON THE  
PERFORMANCE OF A CENTRIFUGAL IMPELLER.

Fowler, H.S. January 1980. 45 pp. (incl. figures and appendices).

As part of the program of studies on centrifugal impellers, the problem of instability at low flows was investigated. The major cause was found to be flow detachment from the impeller vanes.

Slotted blades were found to be the most effective means of delaying this detachment, and extending the working range of the blower.

Low speed studies were confirmed by a test program on a high speed machine, where it was demonstrated that the improved flow range was accompanied by a general increase of efficiency.

The design and placement of the slots is discussed.

UNCLASSIFIED

1. Centrifugal compressors.
2. Impellers.

- I. Fowler, H.S.
- II. NRC, DME ME-248

NRCC No. 18123

NRCC No. 18123

NRC, DME ME-248  
National Research Council Canada. Division of Mechanical Engineering.

THE INFLUENCE OF BLADE PROFILE AND SLOTS ON THE  
PERFORMANCE OF A CENTRIFUGAL IMPELLER.

Fowler, H.S. January 1980. 45 pp. (incl. figures and appendices).

As part of the program of studies on centrifugal impellers, the problem of instability at low flows was investigated. The major cause was found to be flow detachment from the impeller vanes.

Slotted blades were found to be the most effective means of delaying this detachment, and extending the working range of the blower.

Low speed studies were confirmed by a test program on a high speed machine, where it was demonstrated that the improved flow range was accompanied by a general increase of efficiency.

The design and placement of the slots is discussed.

UNCLASSIFIED

1. Centrifugal compressors.
2. Impellers.

- I. Fowler, H.S.
- II. NRC, DME ME-248

NRC, DME ME-248  
National Research Council Canada. Division of Mechanical Engineering.

THE INFLUENCE OF BLADE PROFILE AND SLOTS ON THE  
PERFORMANCE OF A CENTRIFUGAL IMPELLER.

Fowler, H.S. January 1980. 45 pp. (incl. figures and appendices).

As part of the program of studies on centrifugal impellers, the problem of instability at low flows was investigated. The major cause was found to be flow detachment from the impeller vanes.

Slotted blades were found to be the most effective means of delaying this detachment, and extending the working range of the blower.

Low speed studies were confirmed by a test program on a high speed machine, where it was demonstrated that the improved flow range was accompanied by a general increase of efficiency.

The design and placement of the slots is discussed.

UNCLASSIFIED

1. Centrifugal compressors.
2. Impellers.

- I. Fowler, H.S.
- II. NRC, DME ME-248

NRCC No. 18123

NRCC No. 18123