



NRC Publications Archive Archives des publications du CNRC

Technical report 008-VCOMBO-002 On 8.225 MHz Rx only Helmholtz volume coil 14 cm ID

Volotovskyy, Vyacheslav; Tomanek, Boguslaw

For the publisher's version, please access the DOI link below./ Pour consulter la version de l'éditeur, utilisez le lien DOI ci-dessous.

<https://doi.org/10.4224/17712984>

NRC Publications Record / Notice d'Archives des publications de CNRC:

<https://nrc-publications.canada.ca/eng/view/object/?id=96aefcb1-9e9a-4279-821a-eb0a52f92bbb>

<https://publications-cnrc.canada.ca/fra/voir/objet/?id=96aefcb1-9e9a-4279-821a-eb0a52f92bbb>

Access and use of this website and the material on it are subject to the Terms and Conditions set forth at

<https://nrc-publications.canada.ca/eng/copyright>

READ THESE TERMS AND CONDITIONS CAREFULLY BEFORE USING THIS WEBSITE.

L'accès à ce site Web et l'utilisation de son contenu sont assujettis aux conditions présentées dans le site

<https://publications-cnrc.canada.ca/fra/droits>

LISEZ CES CONDITIONS ATTENTIVEMENT AVANT D'UTILISER CE SITE WEB.

Questions? Contact the NRC Publications Archive team at

PublicationsArchive-ArchivesPublications@nrc-cnrc.gc.ca. If you wish to email the authors directly, please see the first page of the publication for their contact information.

Vous avez des questions? Nous pouvons vous aider. Pour communiquer directement avec un auteur, consultez la première page de la revue dans laquelle son article a été publié afin de trouver ses coordonnées. Si vous n'arrivez pas à les repérer, communiquez avec nous à PublicationsArchive-ArchivesPublications@nrc-cnrc.gc.ca.



October 15, 2010

Institute for Biodiagnostics

National Research Council Canada

For: Charlie Deng

IBD-West, Calgary, Alberta

Technical report 008-VCOMBO-002

On 8.225 MHz Rx only Helmholtz volume coil 14 cm ID

Vyacheslav Volotovskyy and Boguslaw Tomanek

This technical report includes:

- description of the coil (page 2)
- schematics of the coil (Fig. 1)
- photo of the coil (Fig. 2)

The Rx only volume coil of 140 mm inner diameter and 135 mm length is made of 1/8" copper pipe. Two rings were connected in series to provide a resonator structure. Capacitive matching network is employed to connect resonator with a passive T/R switch. When an active decoupling lines are attached an empty resonator's Q value is about 260. Loaded with a human knee Q drops down to 100.

Active switching is provided through DC line. DC current of 0.1 A or higher is required to shut off the resonator and switch the assembly from Rx mode into Tx mode.

The Helmholtz Rx-only assembly to be inserted into a plastic former intended to support Helmholtz-Maxwell set-up designed for transmitting.

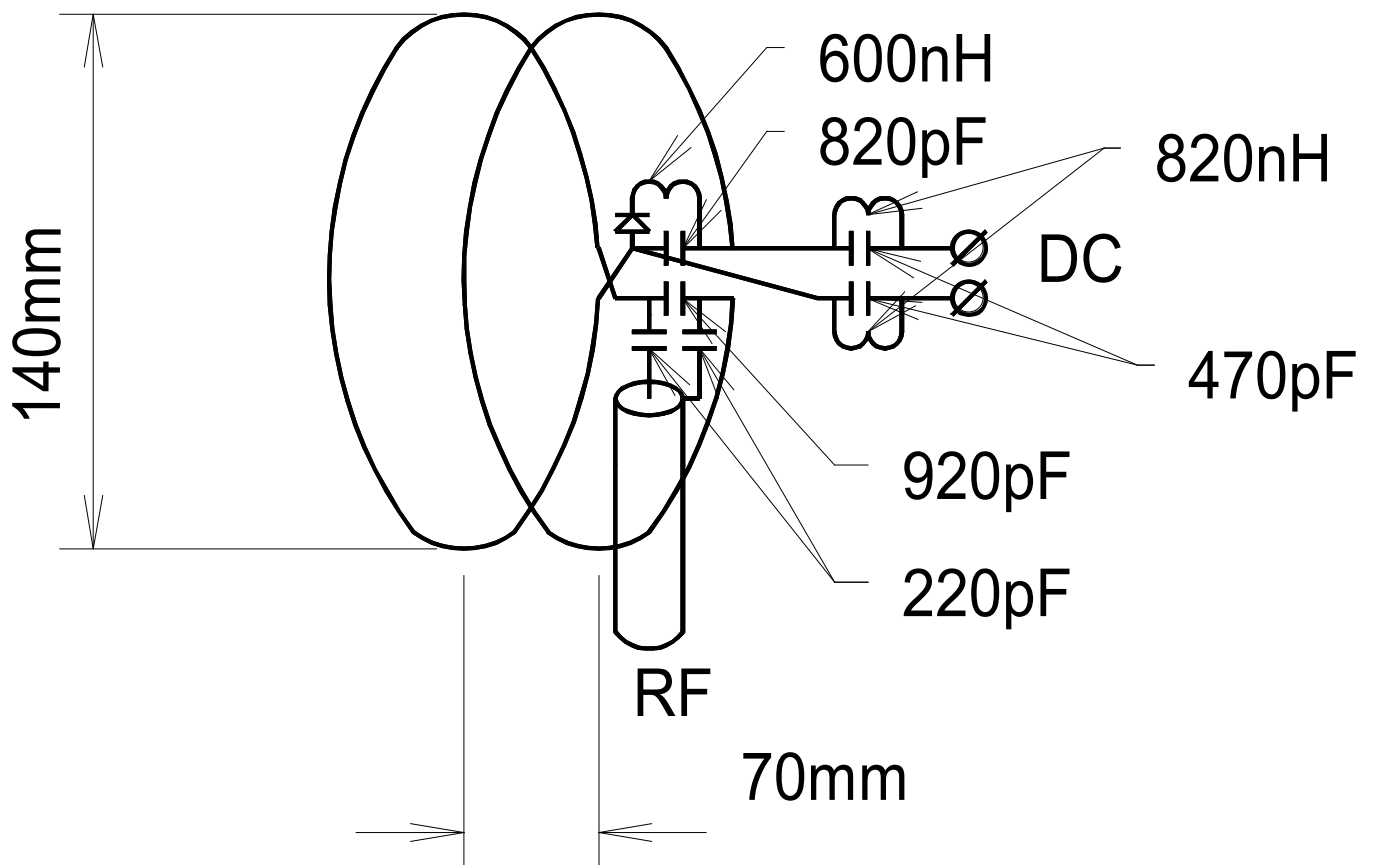

Fig.1. Schematics of the volume coil.

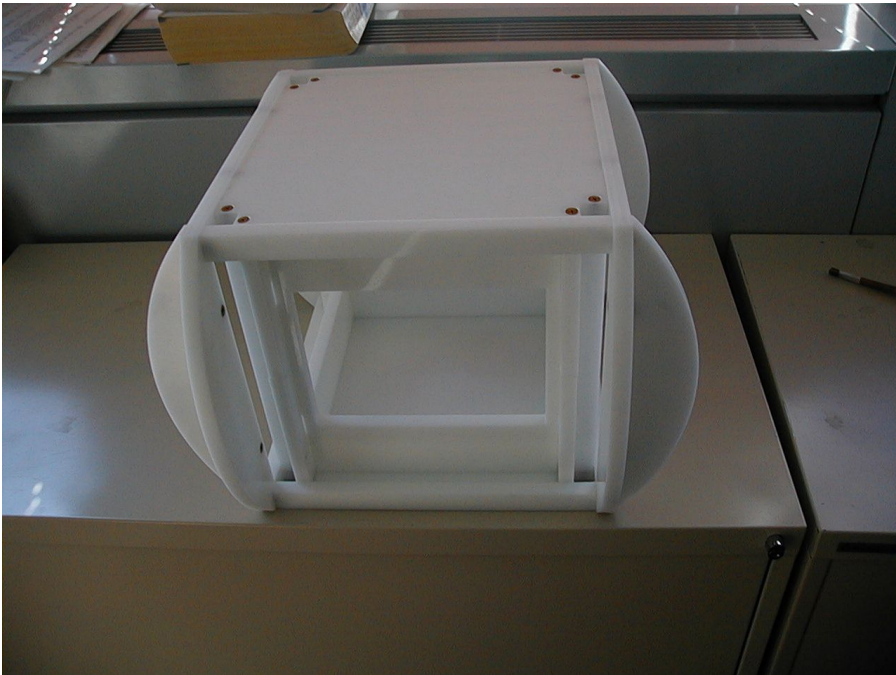
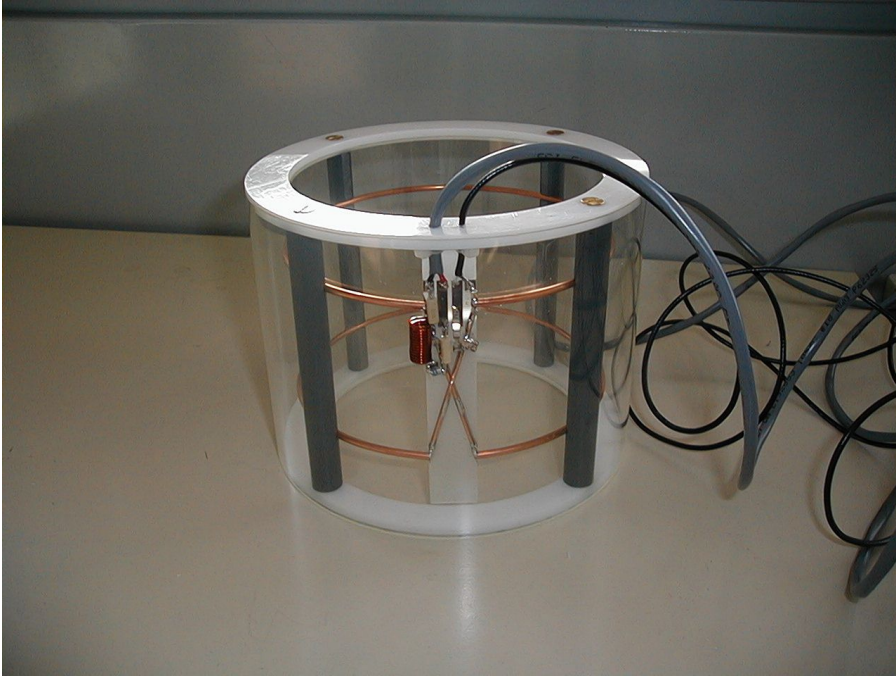

Fig.3. Picture of the Rx volume coil and Tx plastic enclosure.