

NRC Publications Archive Archives des publications du CNRC

Facts and fictions of rain screen walls

Rousseau, M. Z.

This publication could be one of several versions: author's original, accepted manuscript or the publisher's version. / La version de cette publication peut être l'une des suivantes : la version prépublication de l'auteur, la version acceptée du manuscrit ou la version de l'éditeur.

For the publisher's version, please access the DOI link below. / Pour consulter la version de l'éditeur, utilisez le lien DOI ci-dessous.

Publisher's version / Version de l'éditeur:

<https://doi.org/10.4224/40003307>

Construction Canada, 32, 2, pp. 40, 42-44, 46, 1990-03

NRC Publications Archive Record / Notice des Archives des publications du CNRC :

<https://nrc-publications.canada.ca/eng/view/object/?id=3734fcae-528d-4445-bde7-d17883eb9c7b>

<https://publications-cnrc.canada.ca/fra/voir/objet/?id=3734fcae-528d-4445-bde7-d17883eb9c7b>

Access and use of this website and the material on it are subject to the Terms and Conditions set forth at

<https://nrc-publications.canada.ca/eng/copyright>

READ THESE TERMS AND CONDITIONS CAREFULLY BEFORE USING THIS WEBSITE.

L'accès à ce site Web et l'utilisation de son contenu sont assujettis aux conditions présentées dans le site

<https://publications-cnrc.canada.ca/fra/droits>

LISEZ CES CONDITIONS ATTENTIVEMENT AVANT D'UTILISER CE SITE WEB.

Questions? Contact the NRC Publications Archive team at

PublicationsArchive-ArchivesPublications@nrc-cnrc.gc.ca. If you wish to email the authors directly, please see the first page of the publication for their contact information.

Vous avez des questions? Nous pouvons vous aider. Pour communiquer directement avec un auteur, consultez la première page de la revue dans laquelle son article a été publié afin de trouver ses coordonnées. Si vous n'arrivez pas à les repérer, communiquez avec nous à PublicationsArchive-ArchivesPublications@nrc-cnrc.gc.ca.

Ser
TH1
N21d
no. 1666
c. 2

B.D.G.

**National Research
Council Canada**

**Conseil national
de recherches Canada**

Institute for
Research in
Construction

Institut de
recherche en
construction

Facts and Fictions of Rain Screen Walls

by Madeleine Z. Rousseau

Appeared in
Construction Canada 90 03
Volume 32, Number 2
March/April 1990
p. 40-47
(IRC Paper No. 1666)

ANALYZED

Reprinted with permission from
Construction Canada

NRCC 32332



Canada

100 23853

Abstract

Pressure equalization across the exterior cladding of exterior walls is an important feature for the application of the rain screen principle which aims at minimizing rain entry into exterior walls. Confusion exists in the industry about the difference between cavity walls and rain screen walls. The paper focuses on the wall components that contribute to obtain pressure equalization across the outside cladding, that is, a compartmented cavity behind the cladding, a rigid air barrier assembly, and adequate venting area of the cladding in relation to the leakage area of the air barrier. The results of IRC laboratory testing and field monitoring of two buildings of different construction for pressure-equalization performance are briefly presented, with discussion of possible reduction of the design wind loads for rain screen cladding.

KEY WORDS

exterior cladding, rain screen, wall, masonry, precast concrete panel, wall cavity, pressure equalization, wind loads, air barrier

Résumé

L'équilibrage de la pression de part et d'autre du parement extérieur des façades est une condition importante pour l'application du principe du pare-pluie, qui vise à empêcher le plus possible la pluie de pénétrer dans les murs. La différence entre un mur creux et un mur pare-pluie n'est pas claire pour l'industrie. Cet article porte principalement sur les éléments de mur qui contribuent à assurer l'équilibrage de la pression de part et d'autre du parement extérieur, c'est-à-dire une lame d'air compartimentée derrière le parement, un pare-air rigide et une surface de ventilation du parement variant selon la surface de fuite du pare-air. L'auteure présente brièvement les résultats d'essais en laboratoire et de monitoring in situ portant sur deux bâtiments de construction différente et destinés à évaluer leur performance au point de vue équilibrage des pressions, et elle examine la possibilité de réduire les surcharges de vent de calcul dans le cas des parements pare-pluie.

MOTS-CLÉS

parement extérieur, pare-pluie, mur, maçonnerie, panneau de béton préfabriqué, lame d'air de mur, équilibrage des pressions, surcharges de vent, pare-air



Facts and Fictions of Rain Screen Walls

By Madeleine Z. Rousseau, MRAIC

Rain penetration through walls can damage the building envelope. Corrosion of anchors of exterior cladding, efflorescence on masonry, damage and staining of interior finishes are just a few examples of problems due to "mismanaged" rain. As if that is not enough, it can also affect the appearance, the function and the comfort of the space, factors that translate into disruption of the occupants (loss of productivity), into loss of profit for the owner or manager of rented office and commercial space and probably decreased market value.

Proper control of rain penetration is easier and less costly to obtain at the design and construction stages than later on during occupancy. In the latter case symptoms showing up seemingly at random in many rooms (where expensive equipment can be located) of the twelfth floor of a 15-storey building can be distressing to the building owner/manager and to the users of the space. Designers and builders (and building owners) must understand what is required to control rain penetration through exterior walls.

Misunderstood Principles

Inquiries from builders, architects and engineers suggest that drained cavity walls are often confused with

Madeleine Z. Rousseau, MRAIC, is a research officer for the Institute for Research in Construction, NRC, Ottawa.

rain screen walls. Here is an example of how subtly this often appears. When possible causes of rain leakage problems are discussed, the question eventually arises of whether the design and construction of the walls apply the rain screen principle. Quite often, the response is "Yes, they do: there is a drained cavity behind the cladding". Sorry . . . but this fits the description of a cavity wall, not a rain screen wall. A "rain screen wall" is designed and built according to what Kirby Garden referred to as the "Open rain screen principle", whose basic premise is the control of ALL forces that can carry rain to the inside.

Now a heated debate on terminology usually starts! It is clear in my mind that a "rain screen wall" is a wall to which the "rain screen principle" is applied; this expression refers to a given package of requirements set out in Garden's published material twenty-five years ago. Others argue that any wall that uses the cladding as a screen for rain, such as a cavity wall, can be called a rain screen wall. Usually the debate cools off when the expression "pressure-equalized rain screen wall" is used. The term "pressure-equalized" rain screen is particularly useful in that it emphasizes what is ignored or confused, as well as what differentiates it from a drained cavity wall. Pressure equalization in the cavity behind the cladding: this is where the difference between a rain screen wall and a cavity wall

lies. In my view it is a redundant expression, but at least it ends temporarily, arguments on terms so we can focus on HOW to build such a wall.

Cavity Walls

With respect to rain penetration, the concept of cavity walls is based upon the control of some of the forces acting on the cladding i.e. gravity, surface tension, capillary action and rain drop momentum. Decades ago it was used for masonry construction to reduce dampness of inside wall surfaces² (Fig. 1). To control rain entry by capillarity, a large cavity (50 to 75 mm wide) was introduced between the outer and inner layers

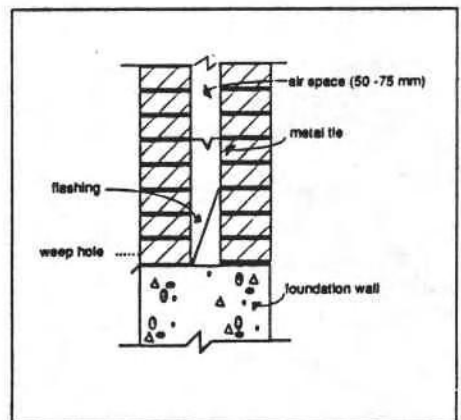

Fig. 1: Masonry cavity wall section, as designed 25 years ago

of masonry: water entering the outer layer would not bridge the large gap to reach the inside layer. Water would then run down on a surface of the cavity to the bottom, and

be collected by a flashing directing the water to little drains, the weep holes. At openings and interfaces with other components such as windows, rain drops can find their way deep into the joint unless a shield (not airtight or watertight) is installed on the outside of the joint to "break" the momentum of the drop; this took care of the rain drop momentum. Surface tension, another manifestation of capillary force, can allow water to go up in a horizontal joint; to counteract this force, a sudden change in direction in the material allows the rain drop to detach from the surface. A groove in a thick material or a labyrinth in a thin one are examples of ways to reduce rain entry by surface tension. Horizontal joints should have a positive slope to drain outward so that gravity works for you. This "drained cavity" approach was later applied to other types of wall besides masonry walls, with varying details depending on the system. As impervious prefabricated cladding panel systems have entered the market, the proper detailing of joints has become critical to the control of all the forces by which rain enters exterior walls.

Even though an exterior wall includes a flashed and drained cavity behind the cladding as well as rain deflectors, it may not control rain penetration adequately because a significant force at play has been ignored: that is, a difference in air pressure across the cladding. This causes infiltration of air and water on windward facades through joints, small pores, gaps, cracks, poorly bonded surfaces and openings that exist or develop during the life of the cladding.

Pressure-Equalized Rain Screen Walls

The rain screen principle entails the control of all the forces handled by a drained cavity wall plus the

air pressure difference acting across the cladding. To many designers and contractors, believing that AIR pressure difference across claddings causes WATER entry is hard to comprehend.

During a rain storm, air infiltration through porous cladding, its joints, cracks and gaps is a great vehicle for water to get a free ride into the enclosure. The rain screen principle recognizes this harmful potential and addresses the control of air pressure difference across exterior cladding assemblies.

No one can stop the wind from blowing! But wall design should be such that the cladding experiences almost no net pressure difference due to wind. Imagine that wind pressure on cladding could practically cancel itself if the pressure is transferred to the back of the cladding. . . in the cavity - (Fig. 2). For the cavity

air flow in the cavity must be minimal. Indeed all you want is to pump in a little volume of outside air to equalize the pressure across the cladding. For this to happen, you need a rigid air barrier; a cavity behind the cladding broken down vertically and horizontally into tight compartments of varying sizes; a large venting area connecting the cavity to the outside; and a somewhat impervious cladding. This is far from the myth spread in the industry which claims that simply venting a cavity (no matter how big the cavity behind the exterior cladding . . . no matter how leaky the inner wall) does the trick of applying the rain screen principle.

Let's examine some of these needs:

A Rigid Air Barrier System

Wind induces large air pressure difference across exterior walls, especially during gusty wind conditions while mechanical ventilation and stack effect cause smaller but steady pressure differentials. Air leakage through a wall system prevents the outside pressure from equalizing across the cladding. This could be compared to trying to inflate a balloon also perforated at the other end: to increase the pressure in the balloon, the easiest way is to make a knot with the perforated end so it is sealed. In construction, this common sense action is called building an air barrier system! An air barrier system will control air flow through the wall system. The balloon example stops working here: the air barrier should be rigid to keep the volume of the cavity constant. A constant volume helps the cavity "bounce back" quickly in response to rapid pressure fluctuations (during wind gusting), e.g. reducing time lag for pressure equalization across the cladding. A

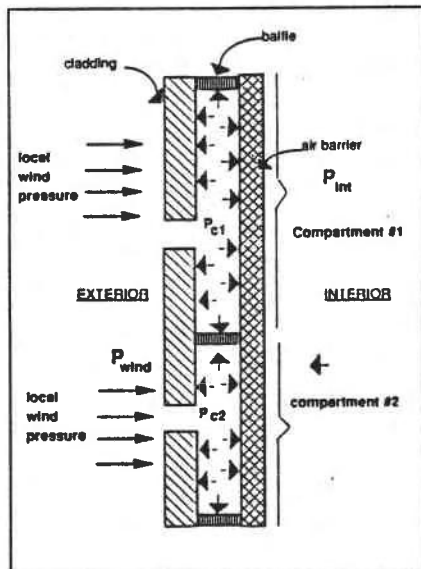

Fig. 2: Equalization of pressure across the cladding needs: a rigid air barrier; a cavity behind the cladding; cavity baffles; and exterior vents in the cladding

to respond quickly to fluctuations in wind pressure, and for proper management of wind in this cavity,

flexible membrane deflecting in the cavity under wind pressure can promote some pumping in of outside air (and rain). Besides, the air barrier system should be rigid for its own sake and durability: this way the pressure loads get uniformly distributed on its surface rather than concentrating fatigue stress at the supports.

A Cavity

A cavity behind the cladding acts as a site for the outside pressure to be transferred, a capillary break and a channel for drainage. The net width of the cavity should be about 25 mm. Allowances for site tolerances and possible blockage of the cavity with debris and (mortar for masonry cladding) should be made. The larger the cavity, the more venting needed to obtain an equalization of pressure in it.

A Compartmented Cavity

Lateral air flow within the cavity can occur without air passing through the wall. This air flow is due to variations in wind pressures over the height, width and geometry of the facade: outside air (and rain, remember) flows into the cavity through vents in locations of higher pressure, and out of the cavity through vents in areas of lower pressure, messing around in the cavity (and insulation possibly) on its way out. Corners and tops of buildings are usually exposed to extremely sharp pressure gradients, where the windward side is exposed to high positive pressure and the other side is subjected to high negative pressure. Pressure equalization across the exterior cladding cannot be achieved without proper control of lateral air flow within the cavity³. It should be divided into a series of tight compartments; then the range of pressure variations that each compartment senses is reduced, and chances of getting a

quick equalization of pressure in each compartment will increase.

How large should the compartments be? Their size should be based on the pressure ranges they are likely to experience. Since wind pressures are usually more uniform in the center of a flat facade than at the corners, compartments can be larger in the centre and should be smaller at the corners (a wind tunnel study stressed the importance of compartmenting corners³). Garden¹ suggested compartments every 1.2 m (4 ft) at the ends and tops of walls in a 6 m (20-ft) wide perimeter zone, and on 3 to 6 m (10 to 20-ft) centres in both directions over the central portion (Fig. 3). Existing components of walls can act as cavity

wall designed as a pressure-equalized rain screen wall system indicated that mechanically attached extruded polystyrene foam strips suited this wall system in providing the features required to reduce lateral air flow and in remaining in place. It may be that strips of wood, sheet metal and rigid plastic may also prove suitable as long as they do not interfere with other requirements for the wall such as fire and heat flow controls. In 1989 Canada Mortgage and Housing Corporation (Jacques Rousseau at (613) 748-2013) initiated a project to define better the features required for rain penetration control using the rain screen principle as applied to typical claddings (masonry, stucco, clapboard) used for wood-

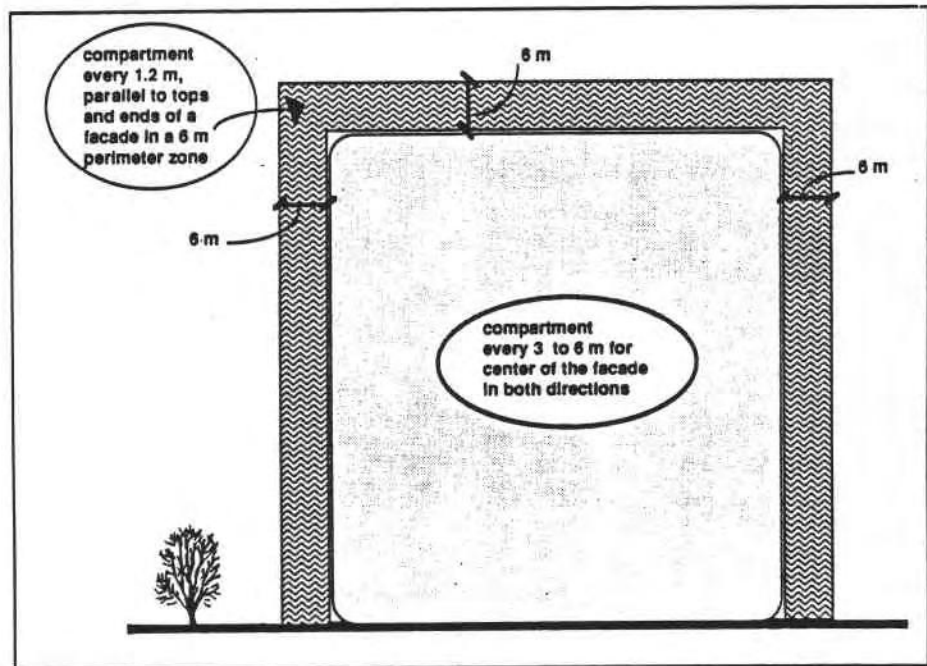

Fig. 3: *Compartmentation over a flat facade due to wind pressure variations*

baffles: windows, flashings, shelf angles, balconies, furring strips etc. At this stage no guidelines exist on the airtightness, the strength and the connections of these cavity baffles. Field monitoring of a precast concrete sandwich panel

frame construction. The project involves laboratory experiments under steady-state and some dynamic wind loading conditions.

Venting

To equalize the pressure between two environments, these must be

connected somehow: venting holes connect the cavity to outside. Vents should preferably be located at the bottom of the compartment so they also drain it. All vents of a compartment should be placed at the same height to avoid air flow loops. The vents holes should be at least 10 mm in diameter to prevent formation of a film of water over the holes, which would reduce the useful venting size.

The amount of venting required in the cladding depends upon the tightness of other components of the cavity, i.e. the air barrier system and the baffles. The cladding should be *much leakier* than the other layers of the compartment (air barrier + baffles) so that the cavity pressure is closer to outside pressure than to inside pressure, and pressure drop across the cladding is minimized (Fig. 4).

However a quite small, tight and rigid compartment was used in the experiments, and other types of wall design may call for different ratios. Another study suggests 25 to 40 times more venting than leakage⁶. Most often the cavity baffles will not be that airtight and to account for this, the cladding venting should be even larger than those figures. This approach to venting is quite different from that used for cavity walls, where venting is rather small.

Therefore the tighter the compartment, the less venting of the cladding required for a rapid equalization of pressure. The reverse statement is also technically correct by itself: the leakier the air barrier, the leakier the cladding has to be, *but misinterpreted*, this statement can be hazardous to your health! Indeed you may end up with

open the tap on the cladding venting, because this could cause problems. The air barrier system should be as tight as possible, whether it is for the control of rain, condensation or noise. After having evaluated the air barrier tightness, the venting of the cladding should be established to fit the recommended ratio. To obtain the airtightness value of the air barrier component proposed, testing of a mock-up wall compartment may be required since little information on the range of airtightness of generic as-built wall air barrier components is available.

Wind Loading on the Cladding

The proper application of the rain screen principle reduces not only the water loads on the cladding but also wind loads. Indeed the foundation of the principle is the achievement of the same pressure on both sides of the cladding. In theory, a well performing rain screen wall should have all wind loads sustained by the air barrier system, and consequently the structural requirement for the exterior cladding and its anchorage could be greatly reduced. In practice this may happen under sustained pressure in a well designed rain screen wall. However under gusty wind conditions, the cladding does sustain some wind loading because of time lag in getting pressure equalization across the wall, as proven by monitoring two buildings for a year and a half⁷ while a wind tunnel investigation was performed on similar walls³.

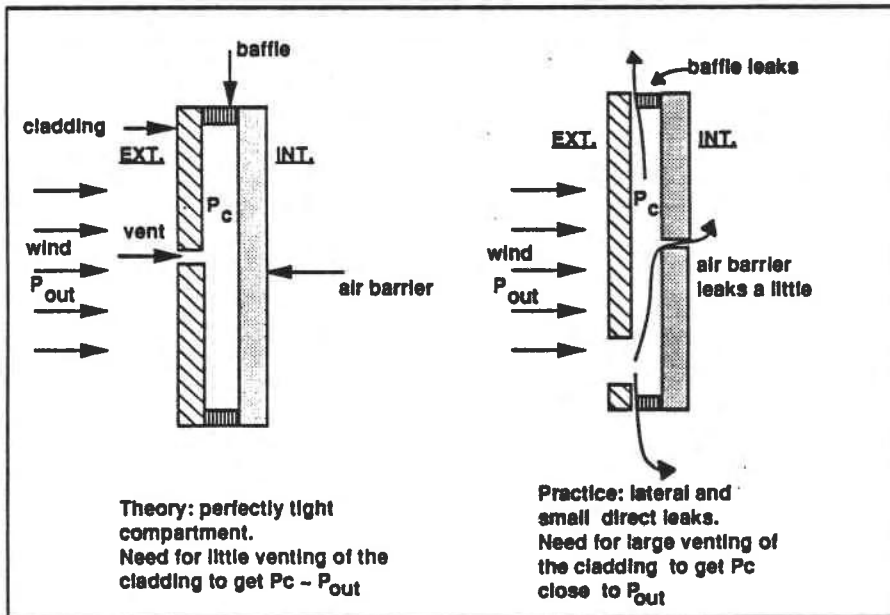

Fig. 4: Need for venting of the cladding vs leakage of the compartment

Latta⁴ calculated that a 10:1 ratio for cladding leakage/air barrier leakage could be satisfactory. Recently IRC laboratory experiments involving tight curtain wall systems confirmed this figure⁵.

a leaky wall and its associated array of potential problems, e.g. uncontrolled flows of moisture, dust, noise and heat. So don't neglect provision of a proper air barrier on the basis that all you need is to

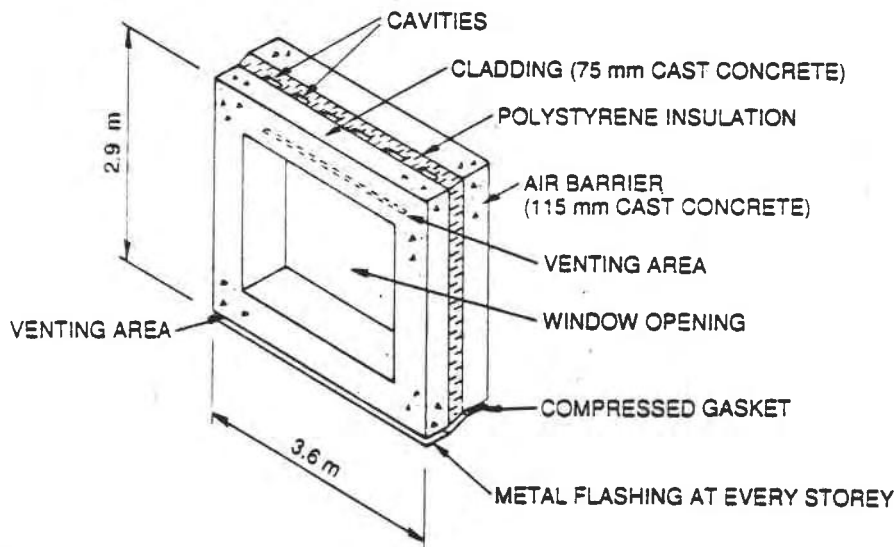

Fig. 5: Building A. Isometric view of a compartment

that all the pressure drop could occur across the air barrier; so this implies the air barrier system was well designed and built. In general, under sustained (several seconds or more) wind loading, the loads on the cladding were small (up to 50-60 Pa); this indicated that the potential for rain entry is minimized. However rapid changes in outside air pressure, especially under negative loading (suction), resulted in pressure difference of at least 150 Pa across the cladding, due to the time lag response of the cavity. The largest transient pressure measured across the cladding was 285 Pa. This negative load on the cladding does not affect the rain penetration potential in the walls but the peak short-lived pressures to be sustained by the cladding and its anchors do affect their structural design. The measurements indicate that the rain screen and its attachments may have to withstand as much as 75% of the design pressure for the whole wall assembly. The results of the wind tunnel investigations of this wall system brought similar figures, indicating the cladding of a "well designed and built" rain screen wall

could be designed for 70% of the design load.

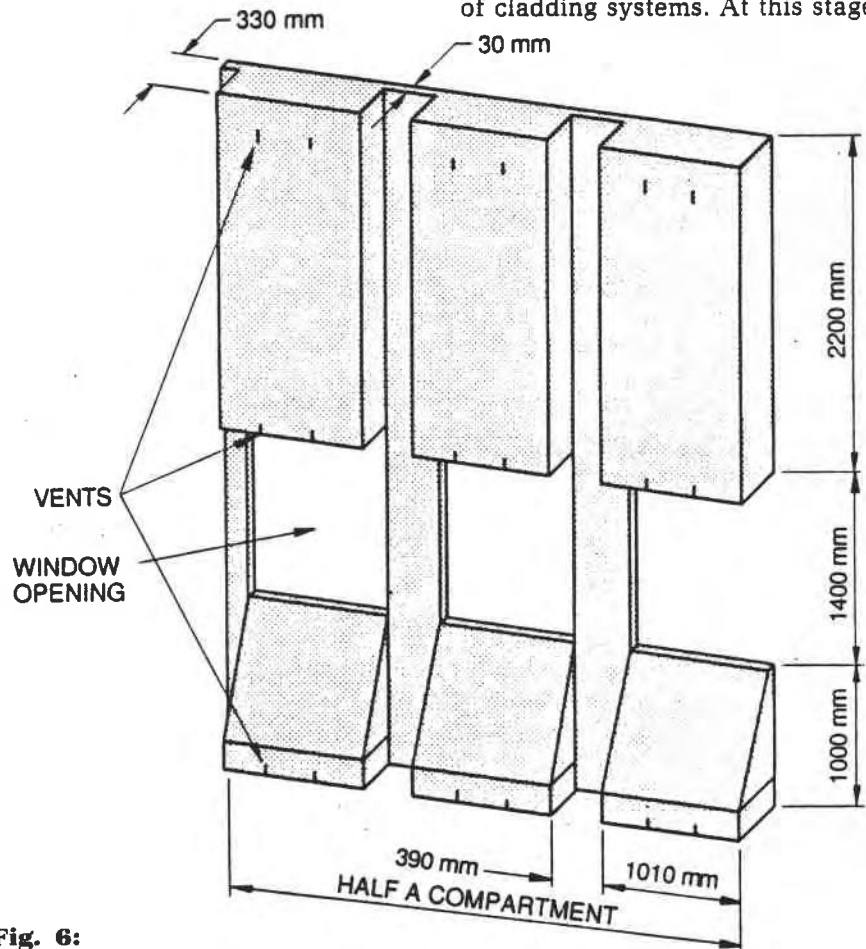

Fig. 6: Building B. Geometry of the compartment

The qualification "well-designed and built" is very critical to the wind loading on the cladding as we found out by monitoring building B. Building B has a masonry cladding, unusually large compartments, little venting and a flexible air barrier unsupported on one side (Fig. 6). What might look at a glance like a pressured-equalized rain screen wall did not perform as such, and the negative wind pressure loads did not get transferred to the air barrier. In positive pressure, the cavity pressure followed the outside pressure but without ever equalizing it. In this case the cladding should be designed to sustain 100% of the design wind loads.

These are fairly serious implications for the structural design of cladding systems. At this stage

wind tunnel studies should be performed on the proposed design if relief of wind loading pressure on cladding is sought by applying the pressure-equalized rain screen principle.

Need for guidelines

Many questions are still pending about the practical considerations to design a pressure-equalized rain screen wall. The maximum sizes of compartments should be the object of further lab and field work since Garden came out with rough figures twenty five years ago. The types of baffles, their attachment and tightness should be tested for their efficiency, ease of installation, and possible trade-off with other criteria of performance. Joints between large prefabricated panels and their interface with other components such as windows can also apply the rain screen principle; guidelines on their design should be developed. A laboratory testing procedure using dynamic wind loading and water sprays would allow the evaluation of mock-up design; IRC is presently working on a project that requires the development of such a procedure. The rigidity of the air barrier in relation to that of the cladding could be investigated. The best way to provide large venting without causing direct rain entry should also be looked at.

Conclusion

The application of the pressure-equalized rain screen principle requires more attention, detailing and care from the designer and builder but is likely to require less maintenance and care from the owner/manager during the service life of the building.

Compared to traditional practice, the proper application of the rain screen principle can result in a reduction of strength required for the cladding and its anchorage system, which must go hand-to-hand with an increase of strength

in the air barrier system and its anchorage system. You may ask, why bother switching the loads from one component to the other? Only a systematic and consistent approach to air and rain flows will produce durable exterior walls that can meet harmoniously all criteria of performance set by designers for the benefits of building owners and users. This systematic approach calls for a continuous air barrier system that not only sustains wind loads, but controls air leakage, moisture flow, noise, pollutants etc. in a durable fashion; it is practically a prerequisite for rain penetration control. □

References

1. Garden, Kirby, *Rain penetration and its control*, National Research Council Canada, Division of Building Research, (Canadian Building Digest no 40), 1963, 4 p.
2. Ritchie, T, *Cavity walls*, National Research Council Canada, Division of Building Research, Canadian Building Digest no 21, 1961, 4 p.
3. Irwin, P.A., G.D. Schuyler and M.A. Wawzonek. (Morrison-Hersfield Limited Consulting Engineers), *A wind tunnel investigation of rain screen wall systems*, NRCC contract no 15SR.31944-3-0014 April 1984, 127 p.
4. Latta, Ken, *Walls, windows and roofs for the Canadian climate*, National Research Council of Canada, Division of Building Research, (NRCC 13487), 1973, p.75.
5. Ganguli U. and R.L. Quirouette, *Pressure equalization performance of a metal and glass curtain wall*, Proceedings 1987 CSCE Centennial Conference Montréal, Québec, May 19-22 1987, vol. 1, p.127-144, (NRCC 29024).
6. Killip, I.R. and D.W. Cheetham, *The prevention of rain penetration through external walls and joints by means of pressure equalization*, Building and Environment, vol. 19, no 2, pp.81-91, 1984.
7. Brown, W C, M Z Rousseau and W A Dalglish, *Field Testing of pressure-equalized rain screen walls*, presented at the Exterior Walls Symposium, Chicago, 1989. To be published by ASTM as a Special Technical Publication.
8. Ganguli, U. and W.A. Dalglish, *Wind Pressures on Open Rain Screen Walls: Place Air Canada*, Journal of Structural Engineering, vol. 114, no 3, March 1988, p.642-656, (NRCC 28859).

This paper is being distributed in reprint form by the Institute for Research in Construction. A list of building practice and research publications available from the Institute may be obtained by writing to Publications Section, Institute for Research in Construction, National Research Council of Canada, Ottawa, Ontario, K1A 0R6.

Ce document est distribué sous forme de tiré-à-part par l'Institut de recherche en construction. On peut obtenir une liste des publications de l'Institut portant sur les techniques ou les recherches en matière de bâtiment en écrivant à la Section des publications, Institut de recherche en construction, Conseil national de recherches du Canada, Ottawa (Ontario), K1A 0R6.