

NRC Publications Archive Archives des publications du CNRC

Design evolution of medium gimbal scalable resistance dynamometer with user manual

Sparkes, Darrell; Pallard, Rob

For the publisher's version, please access the DOI link below./ Pour consulter la version de l'éditeur, utilisez le lien DOI ci-dessous.

Publisher's version / Version de l'éditeur:

<https://doi.org/10.4224/21277548>

Laboratory Memorandum; no. OCRE-LM-2015-003, 2015-12

NRC Publications Archive Record / Notice des Archives des publications du CNRC :

<https://nrc-publications.canada.ca/eng/view/object/?id=2c96ae98-af2d-4509-86fd-ffe942acb6bb>

<https://publications-cnrc.canada.ca/fra/voir/objet/?id=2c96ae98-af2d-4509-86fd-ffe942acb6bb>

Access and use of this website and the material on it are subject to the Terms and Conditions set forth at

<https://nrc-publications.canada.ca/eng/copyright>

READ THESE TERMS AND CONDITIONS CAREFULLY BEFORE USING THIS WEBSITE.

L'accès à ce site Web et l'utilisation de son contenu sont assujettis aux conditions présentées dans le site

<https://publications-cnrc.canada.ca/fra/droits>

LISEZ CES CONDITIONS ATTENTIVEMENT AVANT D'UTILISER CE SITE WEB.

Questions? Contact the NRC Publications Archive team at

PublicationsArchive-ArchivesPublications@nrc-cnrc.gc.ca. If you wish to email the authors directly, please see the first page of the publication for their contact information.

Vous avez des questions? Nous pouvons vous aider. Pour communiquer directement avec un auteur, consultez la première page de la revue dans laquelle son article a été publié afin de trouver ses coordonnées. Si vous n'arrivez pas à les repérer, communiquez avec nous à PublicationsArchive-ArchivesPublications@nrc-cnrc.gc.ca.

Design Evolution of Medium Gimbal Scalable Resistance Dynamometer with User Manual

**Laboratory Memorandum - Unclassified
OCRE-LM-2015-003**

V1.0

Darrell Sparkes

St. John's, NL

December 2015



Report Documentation Form

NRC-CRC

Ocean, Coastal and River Engineering – Génie océanique côtier et fluvial

Report Number: OCRE-LM-2015-003

Program Marine Vehicles		Project Number A1-006478	Publication Type Laboratory Memorandum
Title (and/or other title) Design Evolution of Medium Gimbal Scalable Resistance Dynamometer			
Author(s) – Please specify if necessary, corporate author(s) and Non-NRC author(s) Darrell Sparkes, Rob Pallard			
Client(s) NRC			
Key Words (5 maximum) Resistance, Gimbal, Flex Plate Dynamometer		Pages 85	Confidentiality Period n/a
Security Classification UNCLASSIFIED	Distribution UNLIMITED	How long will the report be Classified/Protected? n/a	
Limited Distribution List (mandatory when distribution is Limited)			

Date:	VER #	Description:	Prepared by:	Check by:
22/10/2015	1.0	Draft	DS	
Click here to enter a date.				
Click here to enter a date.				
Click here to enter a date.				
Click here to enter a date.				
Click here to enter a date.				
Click here to enter a date.				

Fraser Winsor
Program Lead

Jim Millan
Director of R & D



Signature



Signature

NRC – OCRE Addresses

Ottawa
1200 Montreal Road, M-32
Ottawa, ON, K1A 0R6

St. John's
P.O. Box 12093, 1 Arctic Avenue
St. John's, NL, A1B 3T5



National Research
Council Canada

Conseil national de
recherches Canada

Canada



National Research Council
Canada

Conseil national de recherches
Canada

Ocean, Coastal and River
Engineering

Génie océanique, côtier et fluvial

Design Evolution of Medium Gimbal Scalable Resistance Dynamometer with User Manual

Laboratory Memorandum
UNCLASSIFIED

OCRE-LM-2015-003

V1.0

Darrell Sparkes
Rob Pallard

December 2015

Abstract or Executive Summary

This report documents the design, development and operation of a scalable flex plate resistance dynamometer for use in ship model resistance testing at OCRE/NRC St John's replacing and improving on the traditional linear bearing resistance dynamometer. The report also contains the user manual detailing the setup of available operational modes for the dynamometer.

There is also a proposal for future project development regarding an in-situ in line loading apparatus and adoption of the other facility gimbals to the flex dynamometer configuration.

TABLE OF CONTENTS

Abstract or Executive Summary i

1 History 1

2 Concept 1

3 Early Development 1

4 Formal Project..... 1

5 Project Result..... 2

6 Future Development 2

7 Performance of the Dynamometer 2

8 Secondary Development Future Project..... 3

Work Instruction 9

A Procedure 1 – K&R dynamometer 11

B Procedure 2 – Interface SM Load Cells 24

B.1 Troubleshooting 43

B.1.1 Load Cell Flex link Adjustment Procedure..... 44

B.1.1.1 Lost or replaced flex link or washer spacers 45

B.1.1.2 Load cell blocking spacer adjustment slipped 50

B.1.1.3 Load Cell with Different Form Factor..... 53

C Procedure 3- Configuration Change 57

Acknowledgements 58

Appendix A – Standard Uncertainty of Calibration 59

Appendix B – Stop Blocks for Gimbal Storage, Transport and Maintenance64

Appendix C – Load cell positioning blocks 68

Appendix D – Limit Stops 69

Appendix E –Mounting to Cussons Moment Arm Calibrator 70

1 History

Ship model resistance at NRC has been traditionally undertaken using a free heave tow post incorporating a linear bearing Load Cell arrangement. This force measurement system is connected to the hull through a gimbal permitting free roll and pitch of the model under test.

The model is constrained in yaw with a “grasshopper” apparatus typically mounted forward of the tow post with no restriction in heave and pitch.

The linear bearing arrangement had issues with repeatability and linearity in initial calibration. This increases the uncertainty of the measurement not only when using smaller models but also when doing low speed experiments with large models to determine the Prohaska form factor.

2 Concept

A flex plate arrangement similar to a proven in house K&R single component resistance dynamometer for nozzle Open Boat evaluation was proposed. The proposed flex plate dynamometer’s design allowed for use with the current free heave tow post and grasshopper arrangement. Early concept design was approved for further evaluation and development.

The design ensures that the flex plates are under a continuous tension load in test condition thereby eliminating compressive buckling load resulting in failure of such a flex plate system.

3 Early Development

Due to short term project requirements and short schedule dates developmental discussions with involved parties posited the use of the existing K&R into the design. Initial development was reworked to incorporate the K& R single component dynamometer to minimize associated cost while incorporating a proven system. To minimize cost existing gimbal hardware was to be used where possible. The new design was able to be reconfigurable to original operational status should the design prove non-satisfactory in application. Detailed Drawings and Models produced by OCRE were supplied for Manufacture by DFS.

4 Formal Project

The initial test results from the Mark I unit with the K&R adaption proved positive over the linear bearing method leading to a formal AUC for the development and manufacture of the scalable resistance dynamometer unit, an adapter mount for the K&R calibration pull frame, and attached was a preliminary investigative/development of an in-situ model pull-point system.

During early design for Mark II it was decided that the Mark I design could be further modified with removable attachment points to incorporate the scalability function required using an array of different load rated cells with identical form factor. The advantage of this realized cost savings to the design and with minimal effort returnable to the Mark I configuration. The Linear bearing setup would no longer be possible.

5 Project Result

The unit was constructed and tested with results that are comparable to that of the Cussons (K&R) resistance dynamometer. The unit is designed to fit directly onto existing test equipment without modification. Dynamometer scalability is possible with quality Interface SM load cells having the same form factor with various load capabilities ranging from (45 to 670N).

An adapter was designed and built to incorporate calibration of the dynamometer with the Cussons inline thrust/torque calibration jig. Use of this calibration apparatus reduces the uncertainty of the calibration of this dynamometer without preloading of the dynamometer required in previous measurement and calibration systems.

Use of the Interface load cells results in a cost saving when compared with units available from Cussons Technology. The unit is also easily maintained and repairable using in house expertise.

6 Future Development

The current unit was built and sized around the medium gimbal used at OCRE/NRC. Also available are small and large gimbal systems currently using the linear table setup. Further scalable dynamometer units could easily be sized similar to the existing design to fit these gimbals enabling OCRE to have added capability of accommodating models requiring gimbal units of varying footprint sizes.

7 Performance of the Dynamometer

The performance of the dynamometer is assessed by calculating the Standard Uncertainty of Calibration (SEE) for several of the load cell options. SEE is the standard deviation of the residual errors after application of the calibration curve to the data. There was insufficient time to assess all of the load cells that were acquired for the system but the following table illustrates what has been achieved so far. The results obtained with the K&R R-35I are included for comparison

Load Cell	Capacity		SEE	Source	Estimated SEE
	[lbf]	[N]			
SM-150	150	667	0.1666	Baffinland	0.160
SM-100	100	445			0.107
SM-50	50	222			0.053
SM-25	25	111	0.0054	MCTE	0.027
SM-10	10	44	0.0038	MCTE	0.011
K&R R-35I	45	200	0.0295	OTP Nozzle	0.048

SEE is estimated for the two load cells that have not yet been assessed by a linear fit of measured SEE for the load cell systems already calibrated against nominal load cell capacity as shown in the figure below.

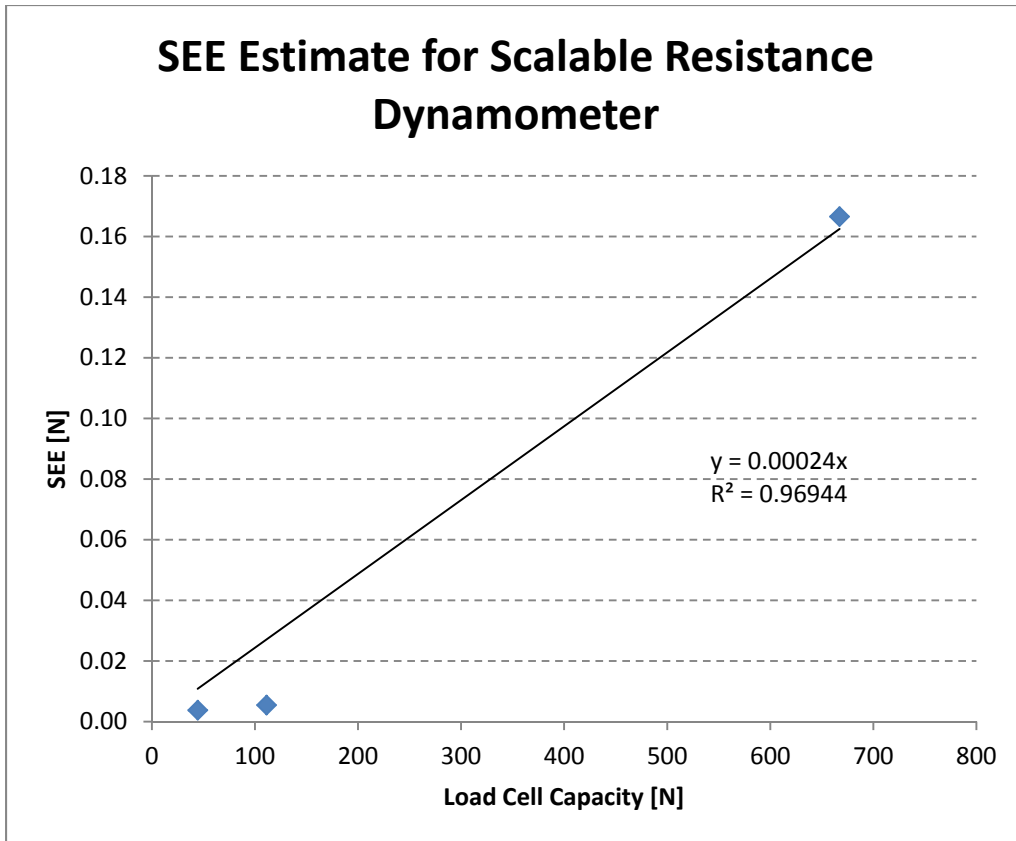

Details of the SEE calculations for each load cell system are given in Appendix A.

8 Secondary Development Future Project

Tow Tank Model Pull Point Development

Current System

The tow tank currently has a two axis adjustable tow post attached to the rear of the carriage that requires a line attachment to the model. Typically an eyebolt is fitted to the model at centerline of the hull on the deck or above waterline at the stern and attachment for the inline check pulls is accomplished through this. There is an in line comparison load cell linked by a shackle to the boat at the eye bolt and the other end of the Load cell is shackled to the pull line. The line is routed through a pulley system several meters aft of the boat to allow weight pan loading of the line from the carriage platform. The system requires connection and disconnection from a boat each time a load pull is required. A pre-load of the system is required to remove the catenary component of the pull caused by the weight of the line and the load cell hanging of the back of the boat. The pull line alignment is also an issue at initial setup ensuring that the tow post is

aligned with the model longitudinally and level with water surface.

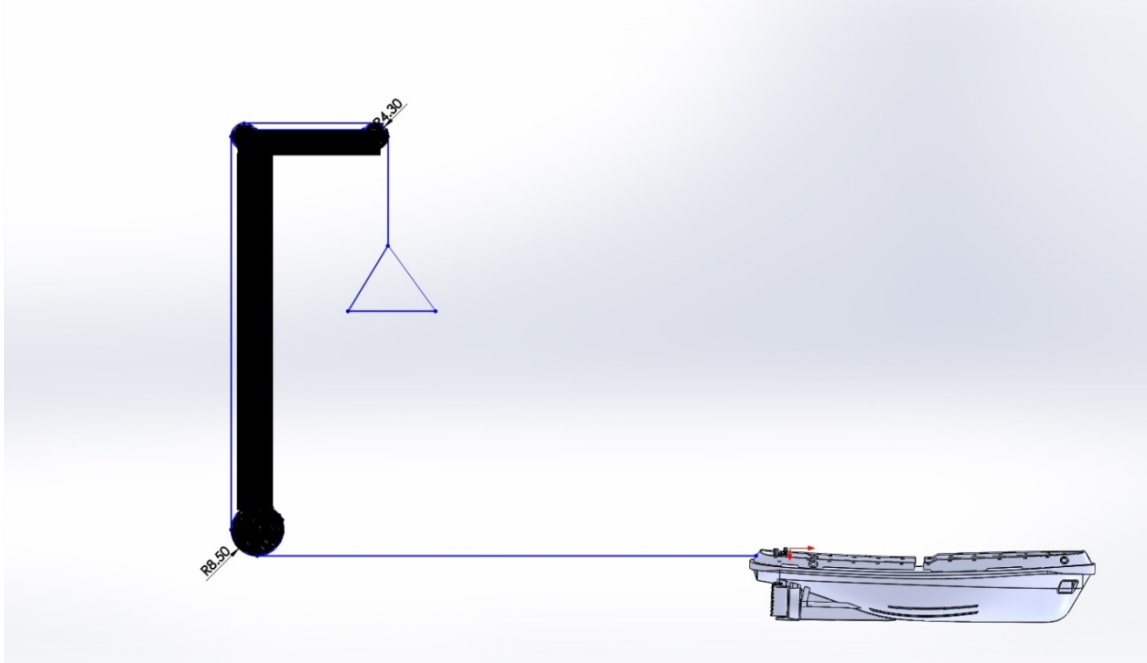

Requirement: A method to improve on pull point checks for models.

Initial concept through discussion with interested parties involved having the pull point integrated into the tow post

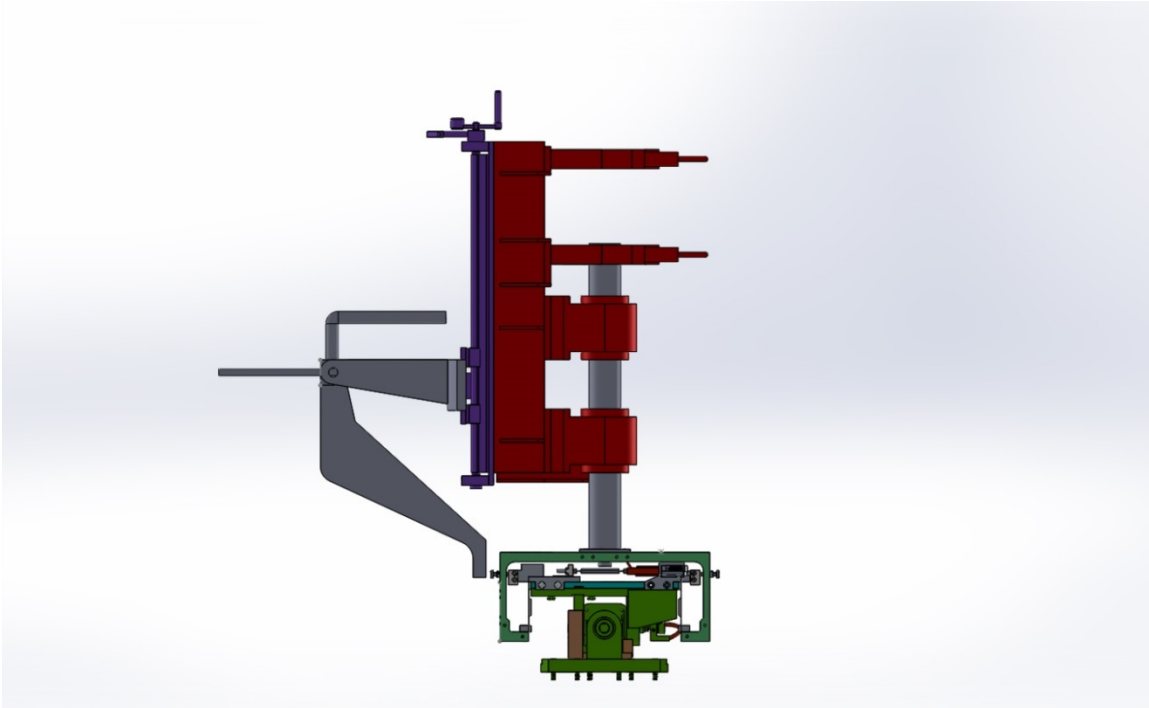

Space, alignment and loading of the device would be of issue.
Separating of the pull unit from the tow post was more effective.

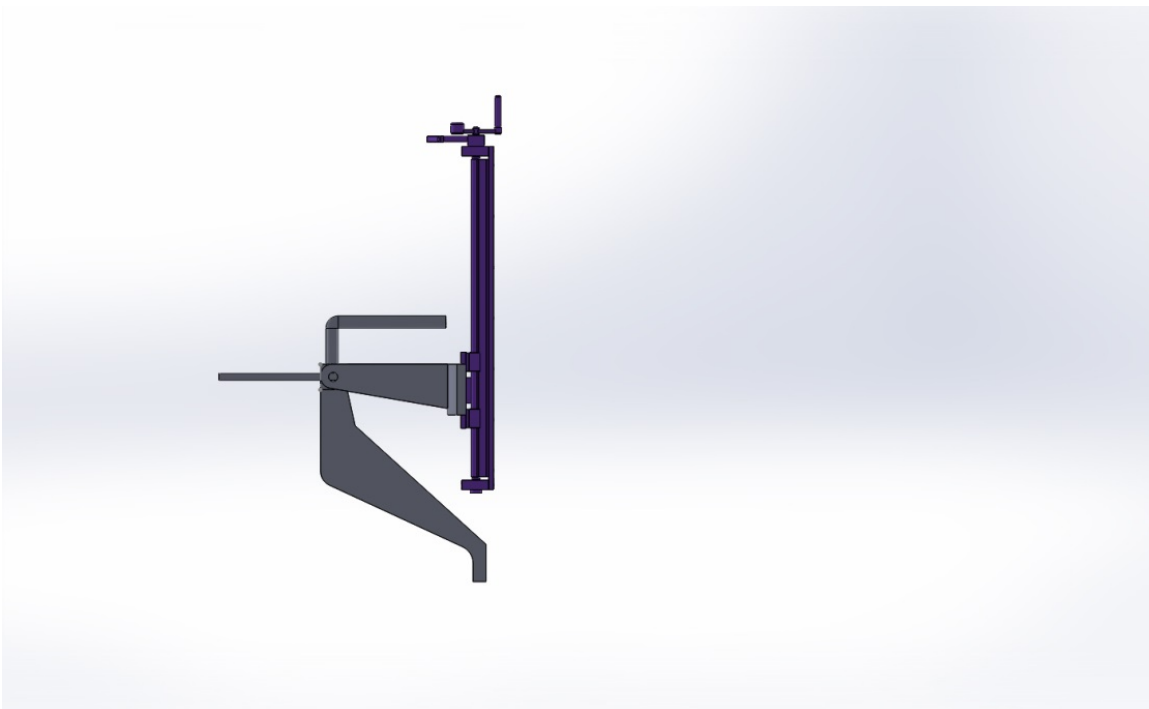

Evolving in a viable option:

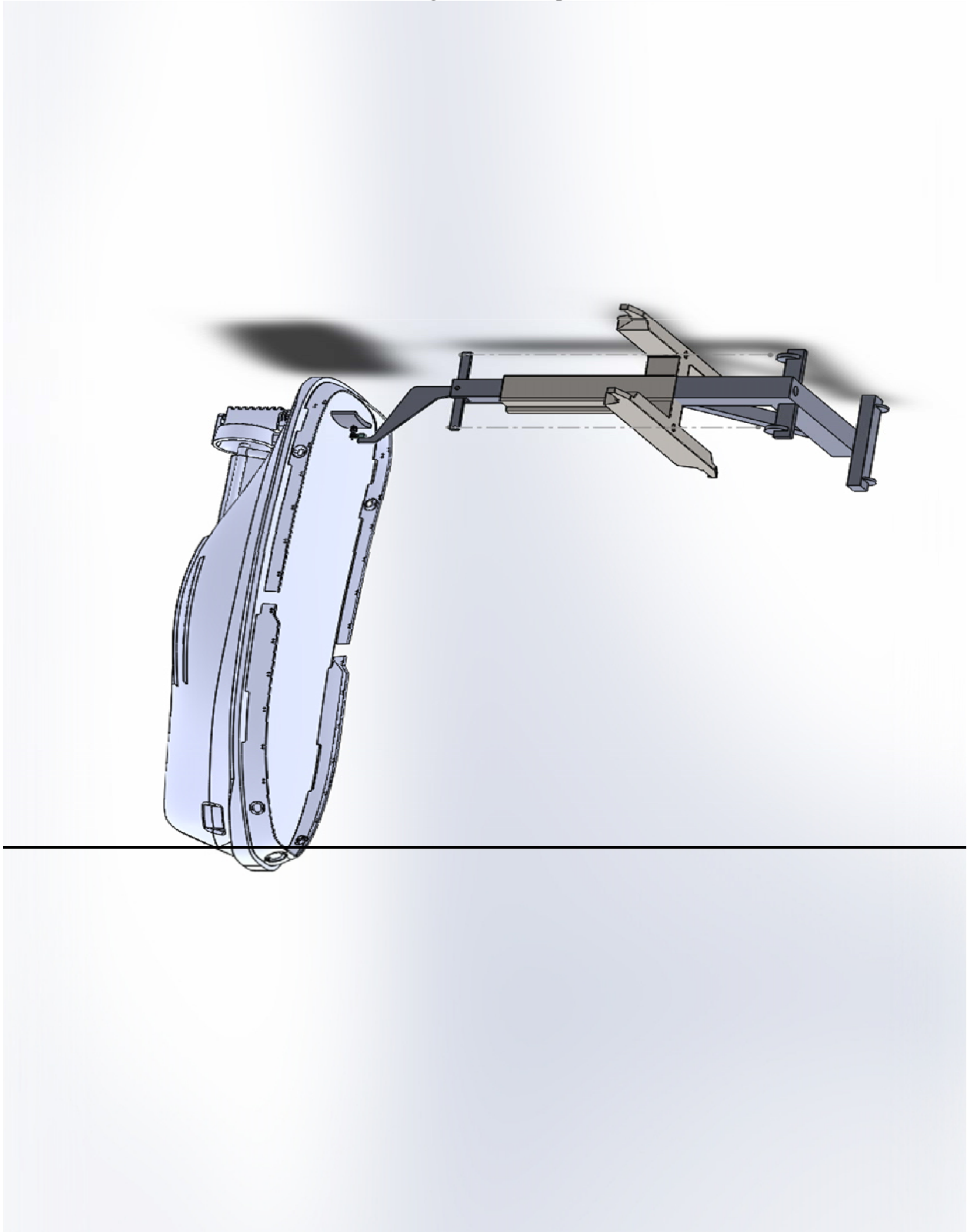

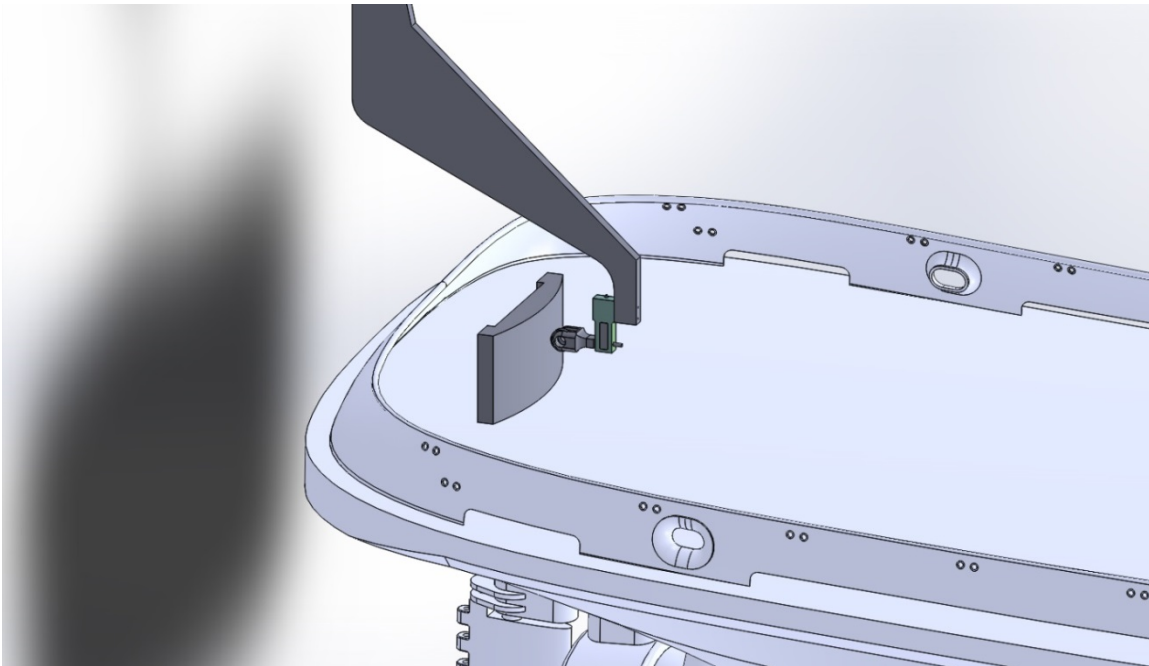

with the following advantages:

- 1) Load cell is incorporated into the unit, not attached to the model
- 2) In line load is direct applied and measured
- 3) Loading is applied from the carriage deck through cable pulleys with no catenary
- 4) No preload required allowing for low load check.
- 5) Unit swings up away from model during testing no boat required no fixed linkage as with cable
- 6) Model heave from tank standing wave not affecting due to roller mechanism
- 7) Rounded contact plate and roller bearing allow for single point contact.
- 8) Model push plate can be incorporated early on in design.
- 9) Center line of pull point apparatus with respect to carriage rail and tow post assured by design .
- 10) Unit can be configured for a push or pull configuration. Current view push.

DWS

Work Instruction

For

K&R Resistance Dynamometer mode

and

Medium Gimbal Scalable Resistance

Dynamometer mode

**OCRE/NRC
St John's**

Scalable Resistance Dynamometer Configurations

A Procedure 1 – K&R dynamometer

Configure gimbal for the K&R nozzle dynamometer

- 1) Block gimbal U-joint for installation (See Appendix A)

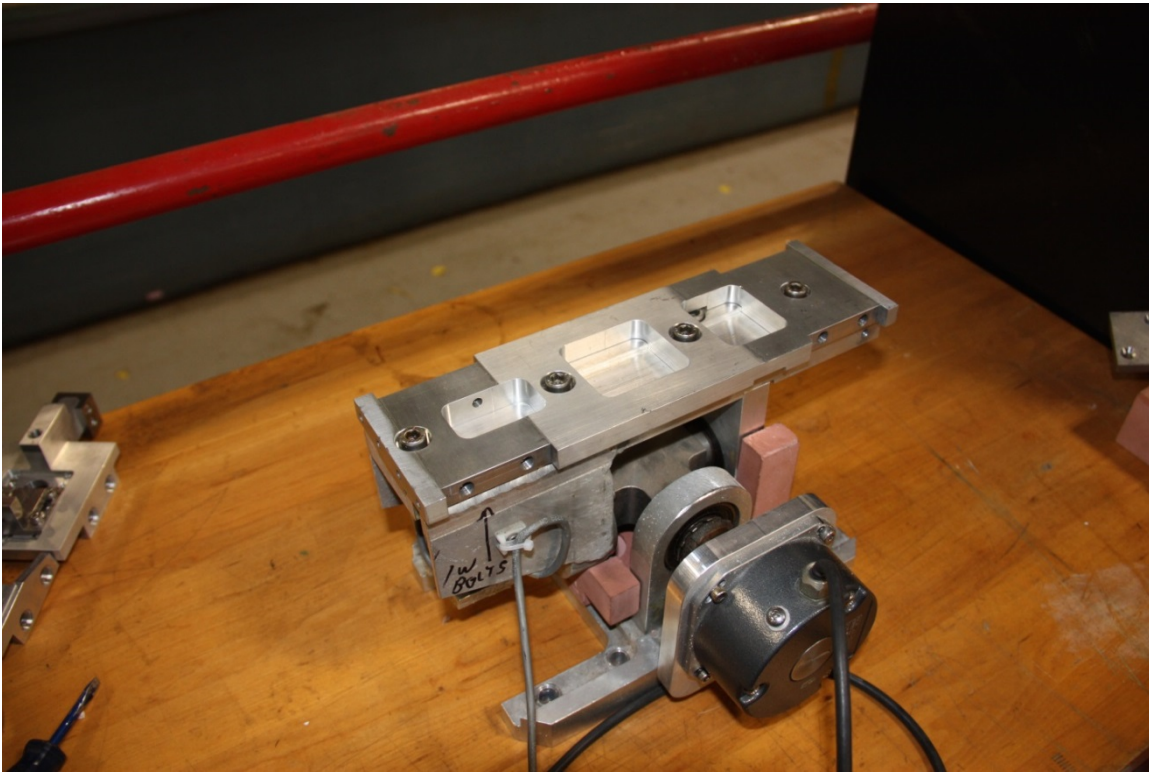



K&R Nozzle adapter brackets required.

2) Install bracket as below (4) cap screw required size: 5/16-18-1/2

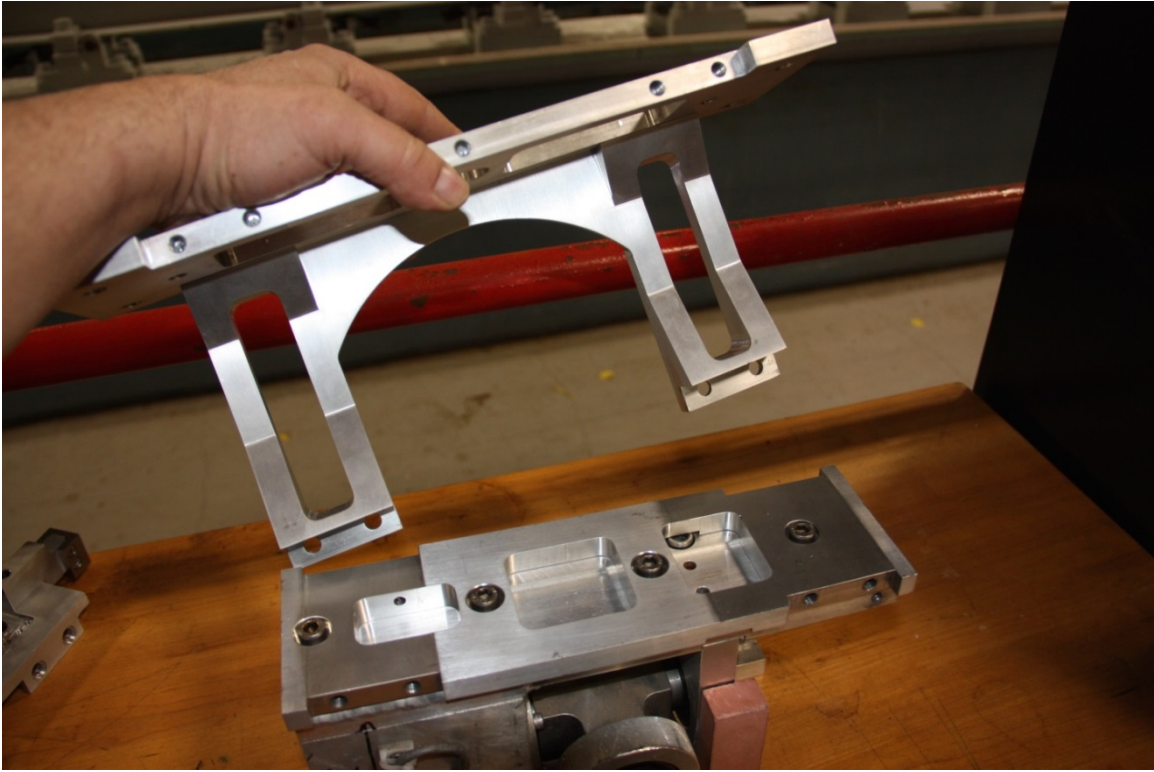

- 3) Ready the Pre-Calibrated K&R resistance dyno for install into bracket

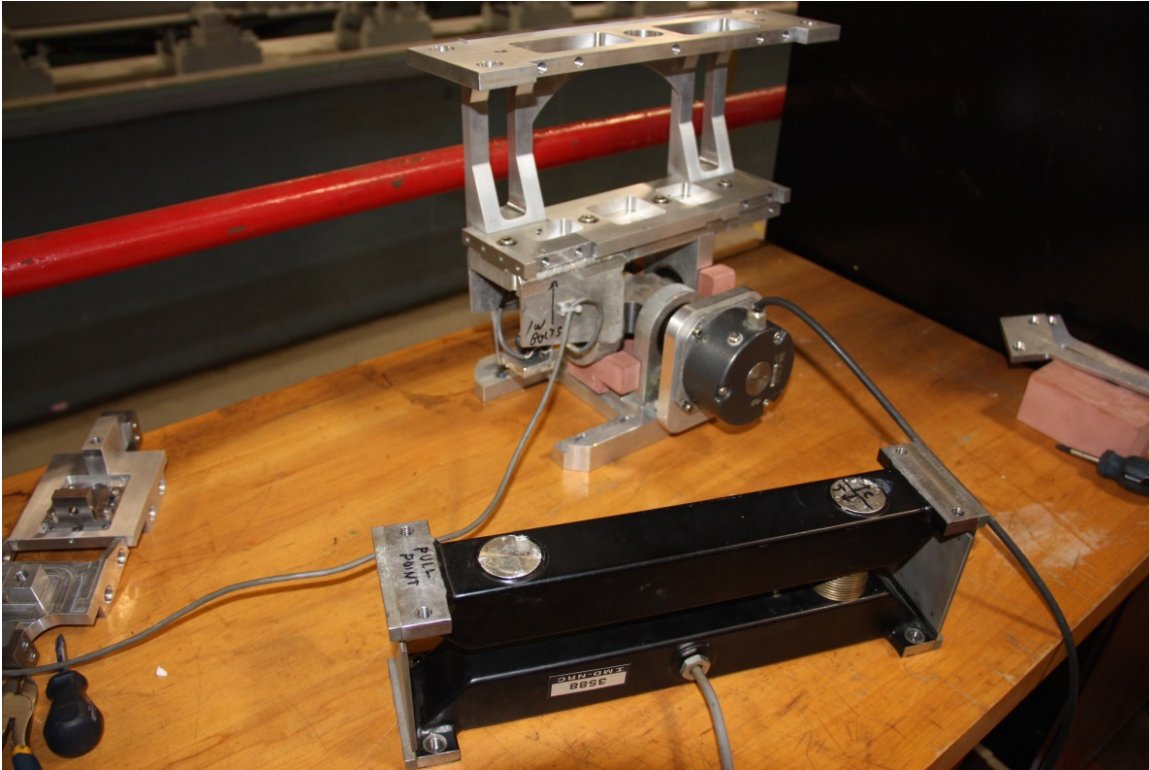

- 4) Lay dyno into bracket dead side (Cabled) down.

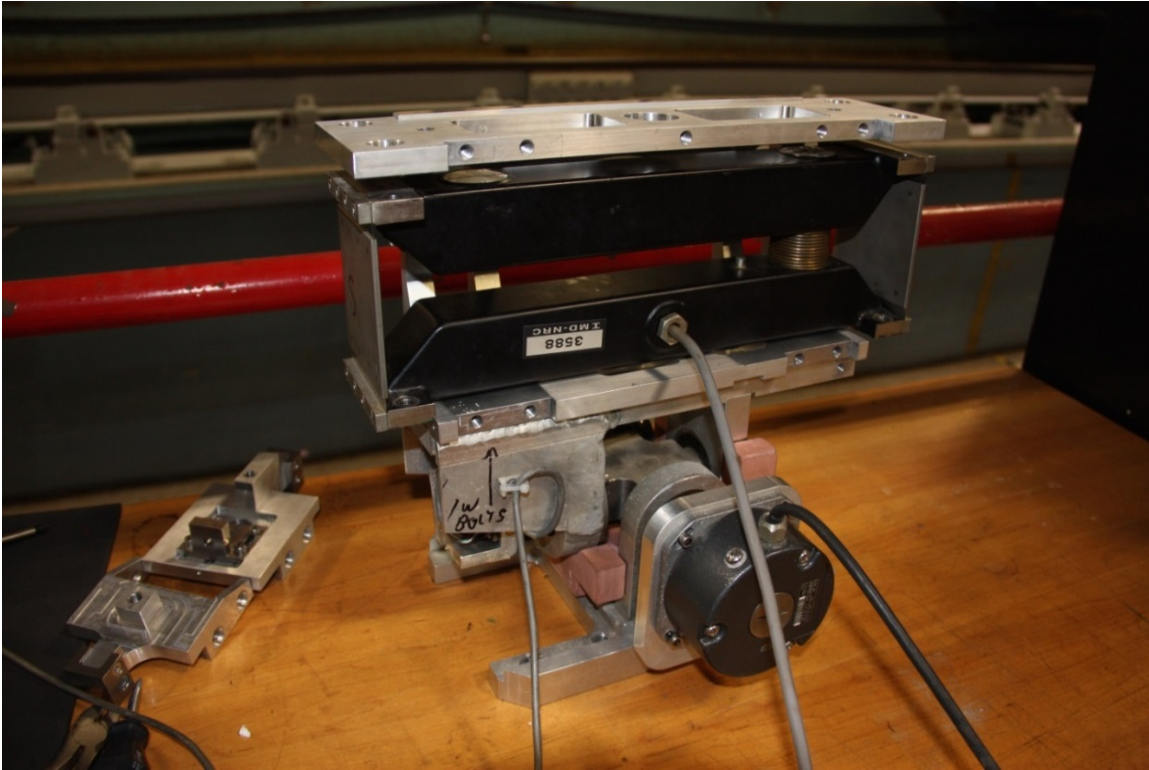

- 5) Draw dyno up evenly unto bracket with metric cap screws. Size: M8-1.25-25

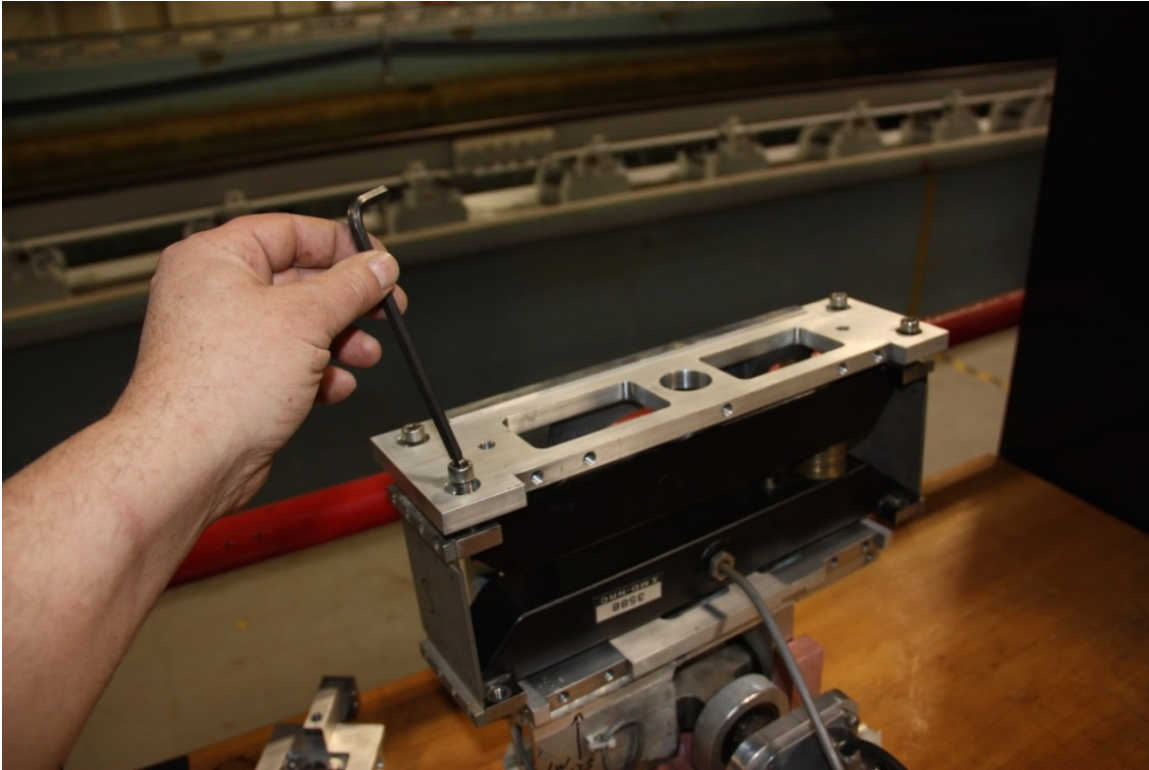

- 6) Install remaining bracket. (9) cap screws size: 5/16-18-1/2

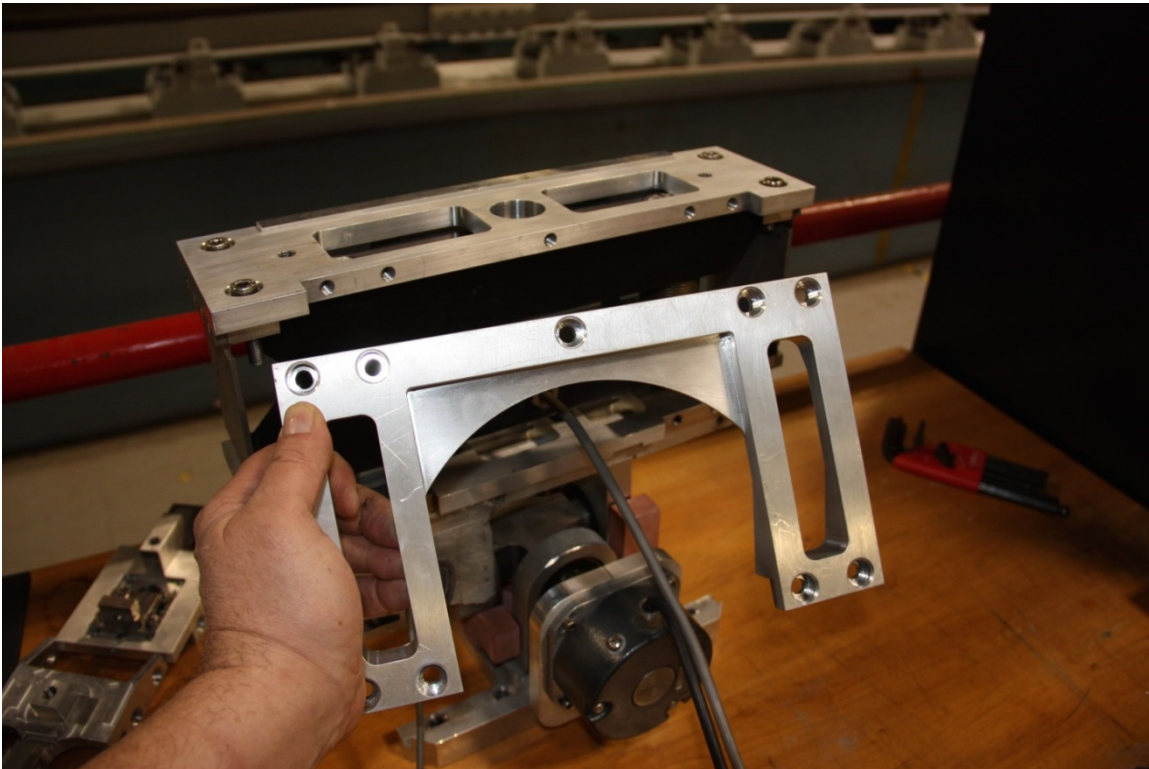

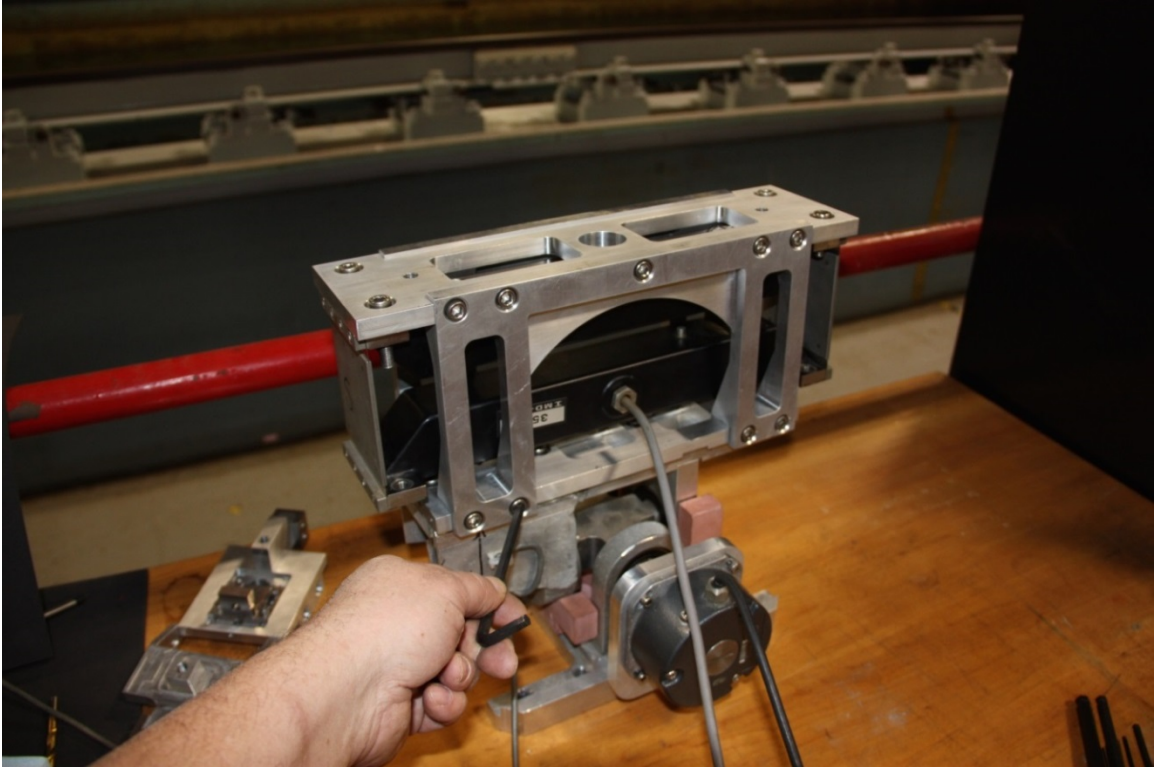

Outer dyno casing



7) Match outer dyno casing bow to K&R bow

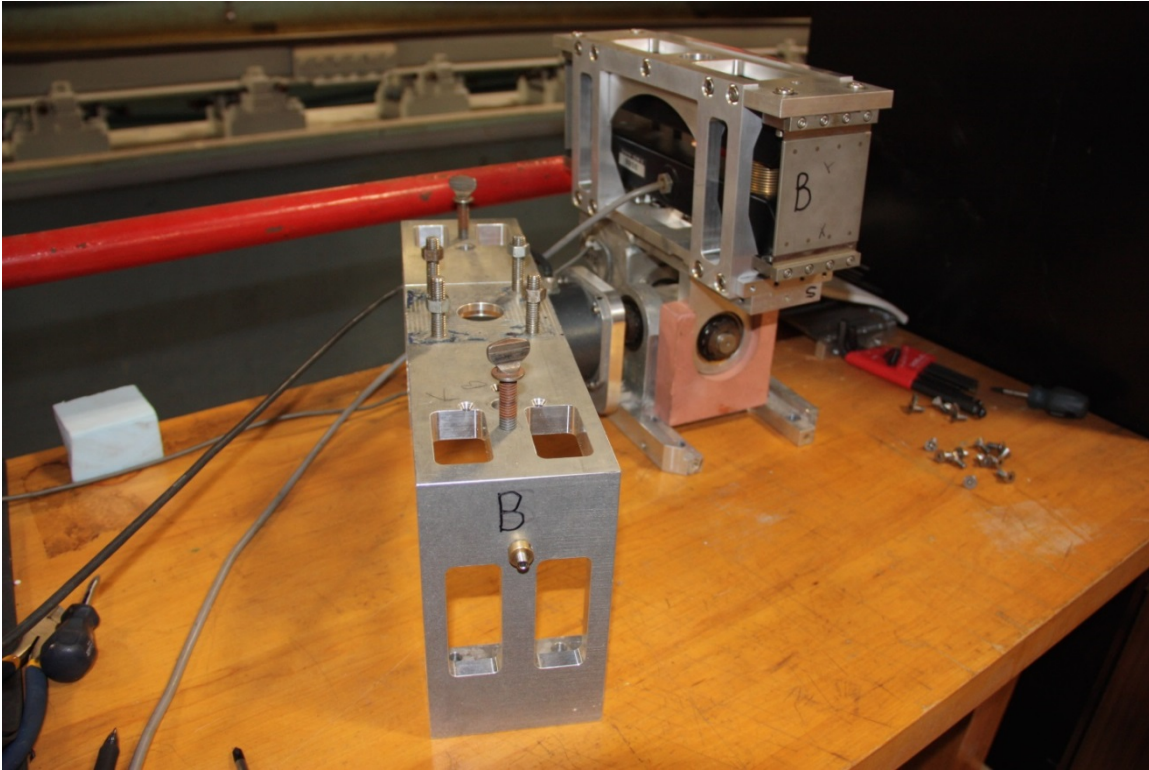

8) Slide on outer dyno casing

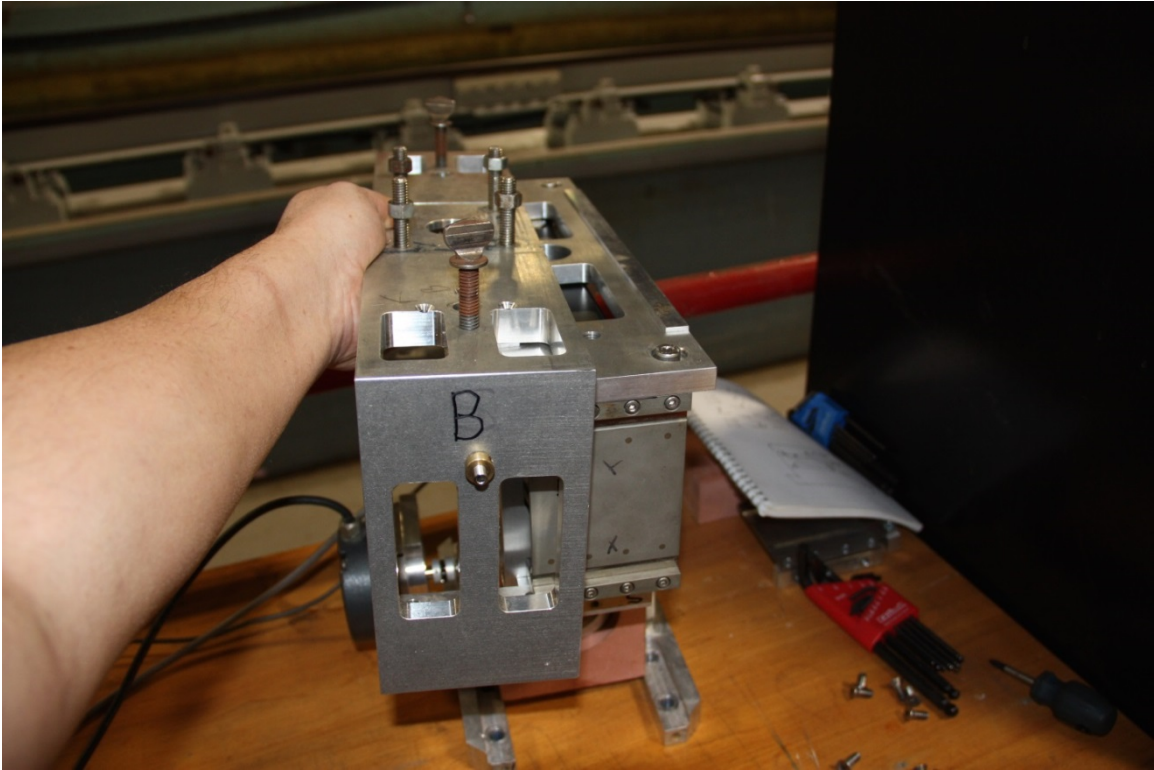

- 9) Draw up outer dyno casing to dyno using four metric cap screws size: M8-1.25-25

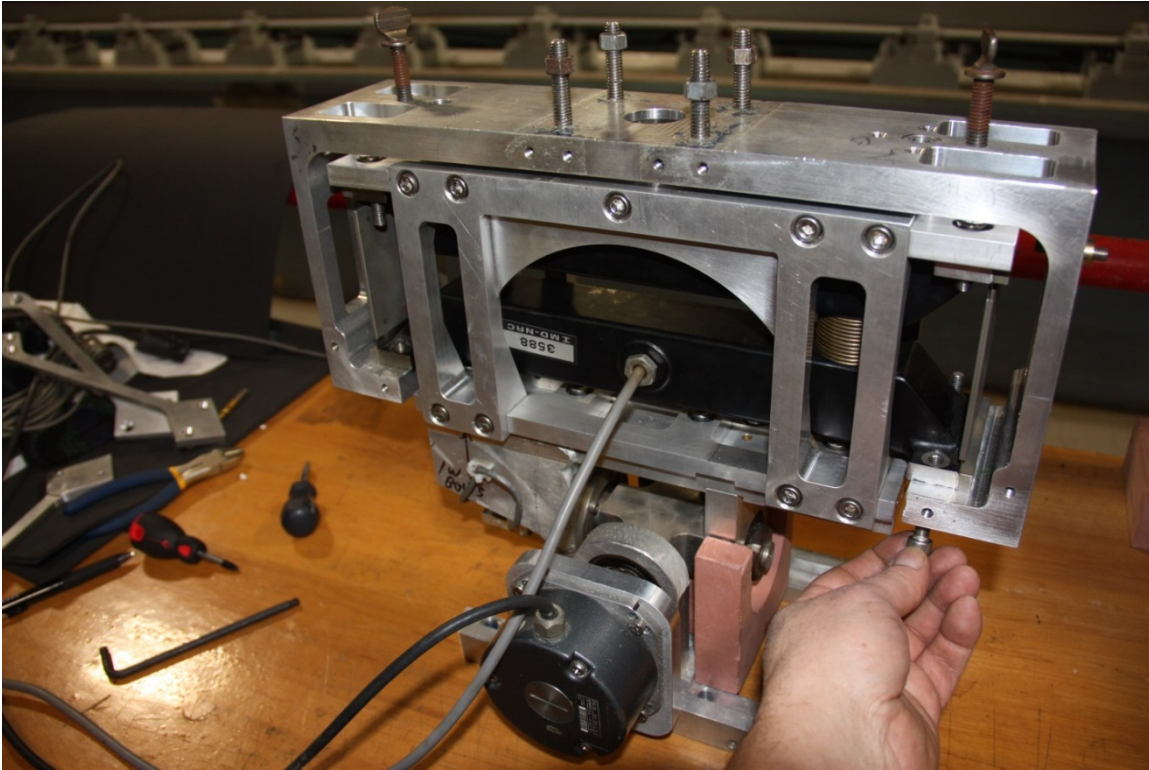

10) Install braces with countersunk Hex size: 1/4-20-1/2

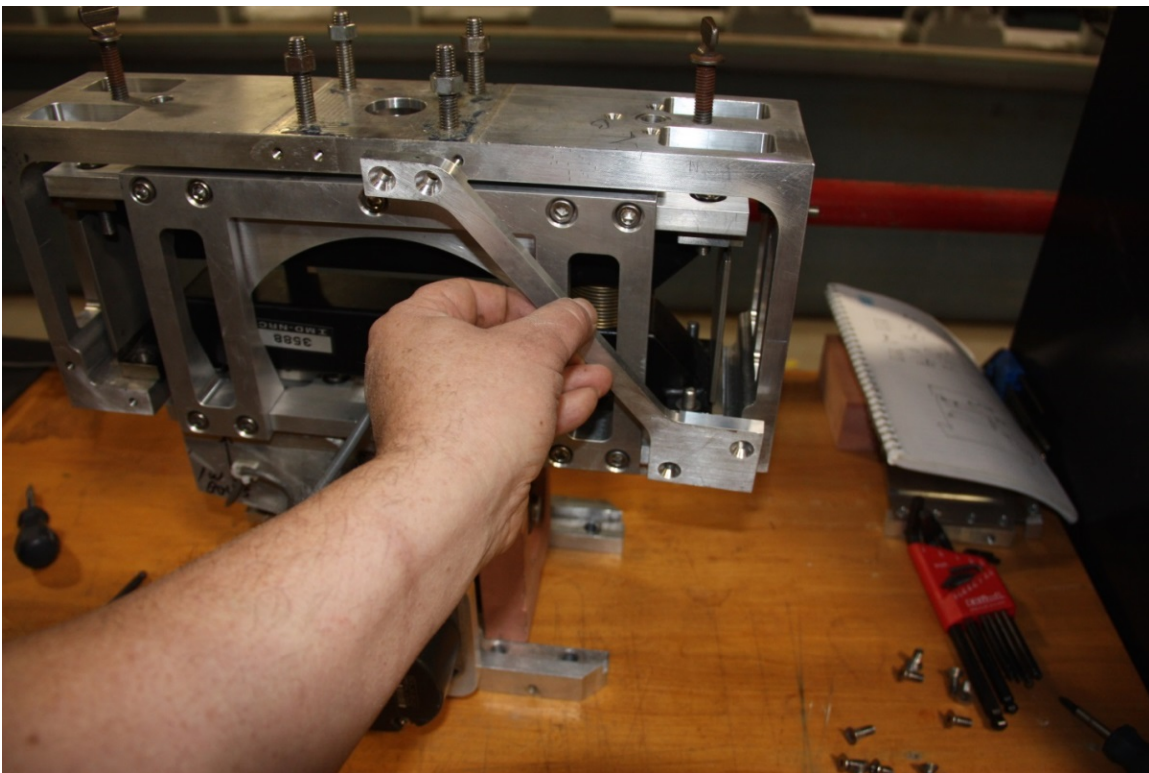
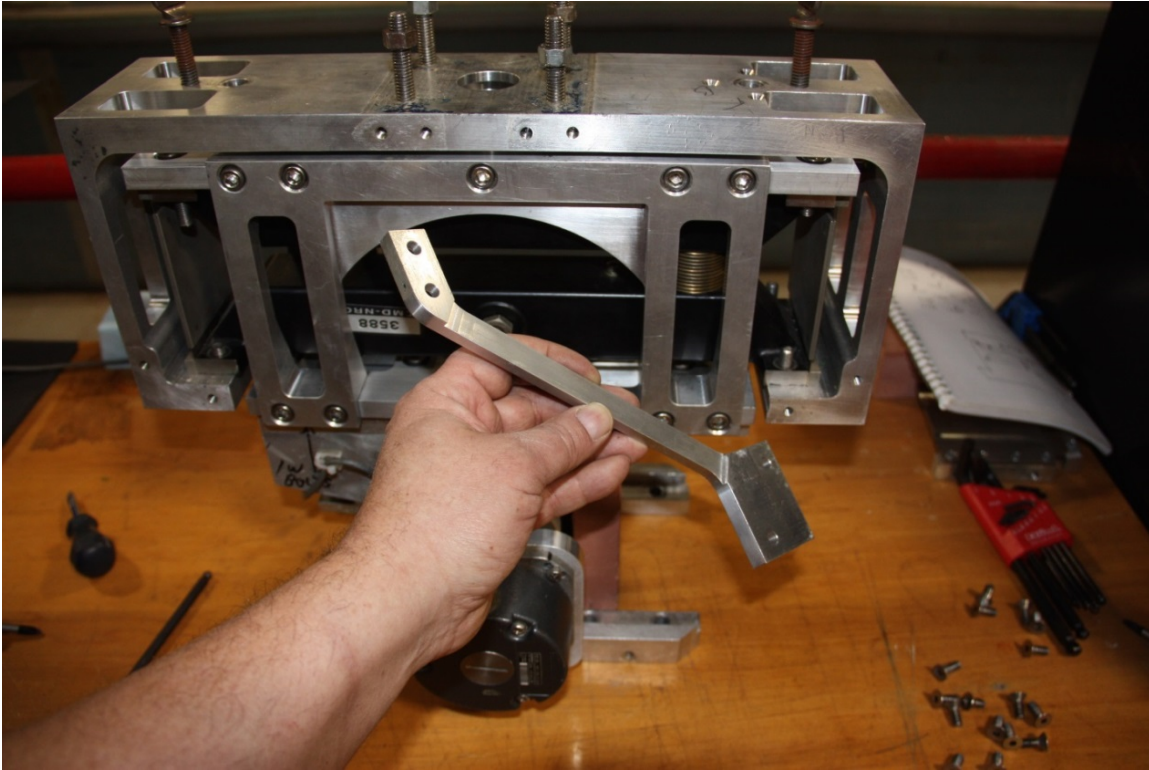

- 11) Dyno assembled. Limit stops should be set as outlined in Appendix C.

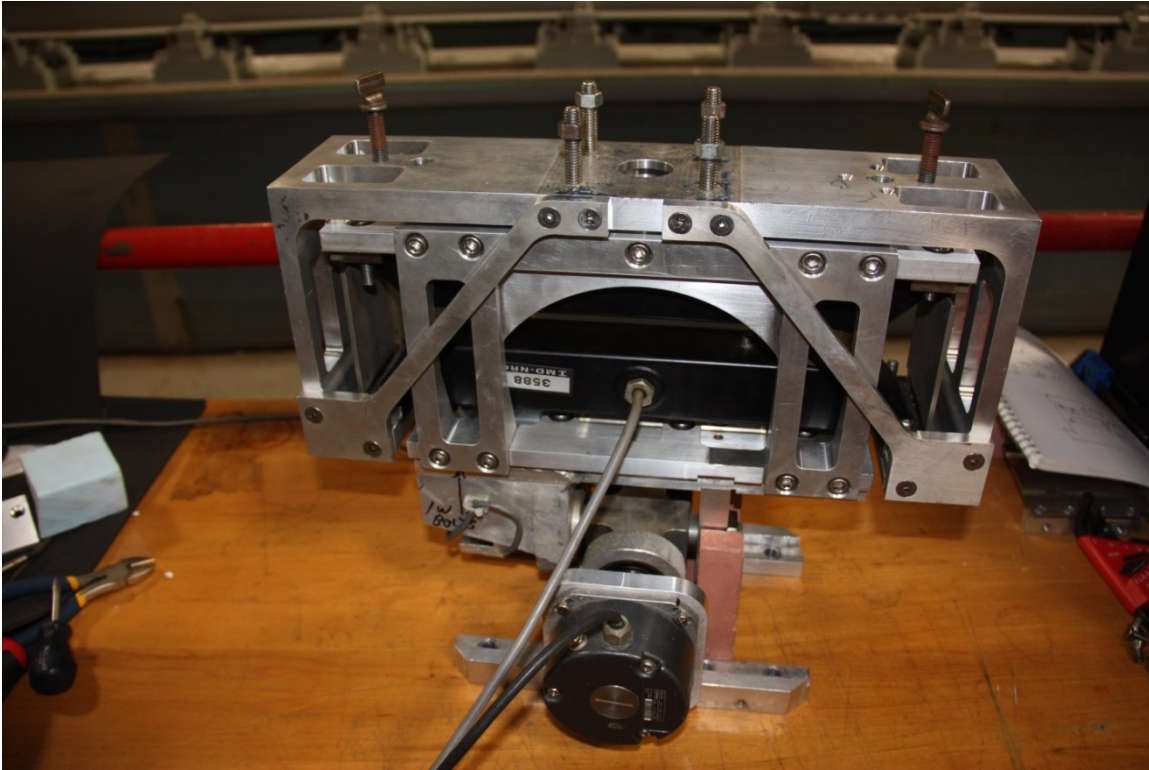

- 12) Install dyno Thumb screw locks before moving or installing dyno in model

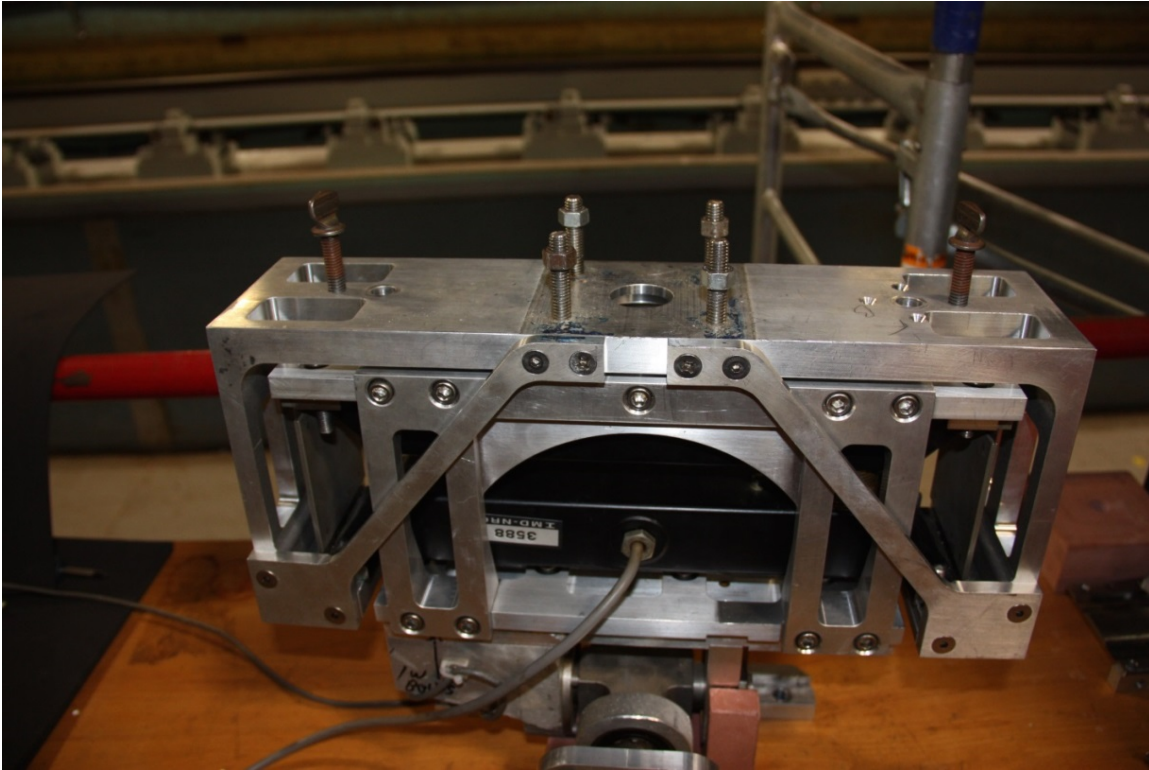

B Procedure 2 – Interface SM Load Cells

Configure gimbal for the Interface SM load cell.

Available ranges are 10, 25, 50, 100,150 lb. load cells.

- 1) Install Flex plates onto outer shell assembly



Flex-plates should be oriented with undercuts facing inward with attachment block on the bottom facing

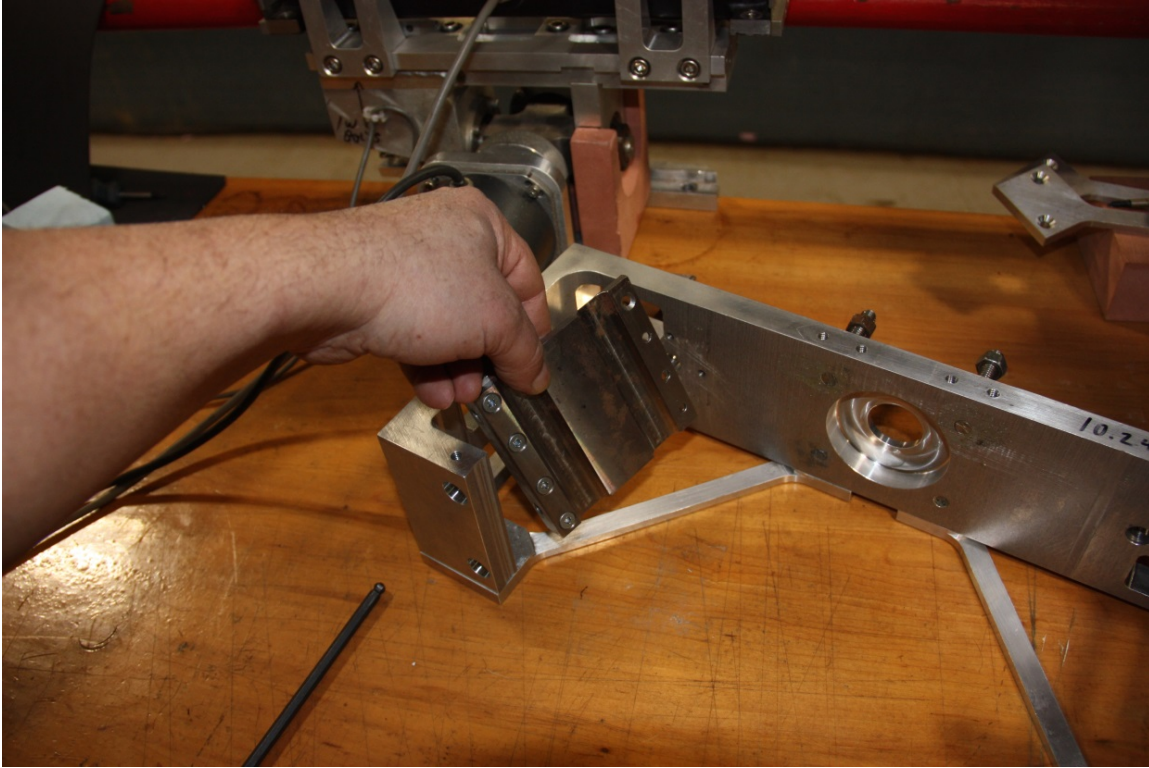

Leave (4) cap screws size: 5/16-18-1 1/2 slightly loose until final assembly and alignment. Set the outer casing aside

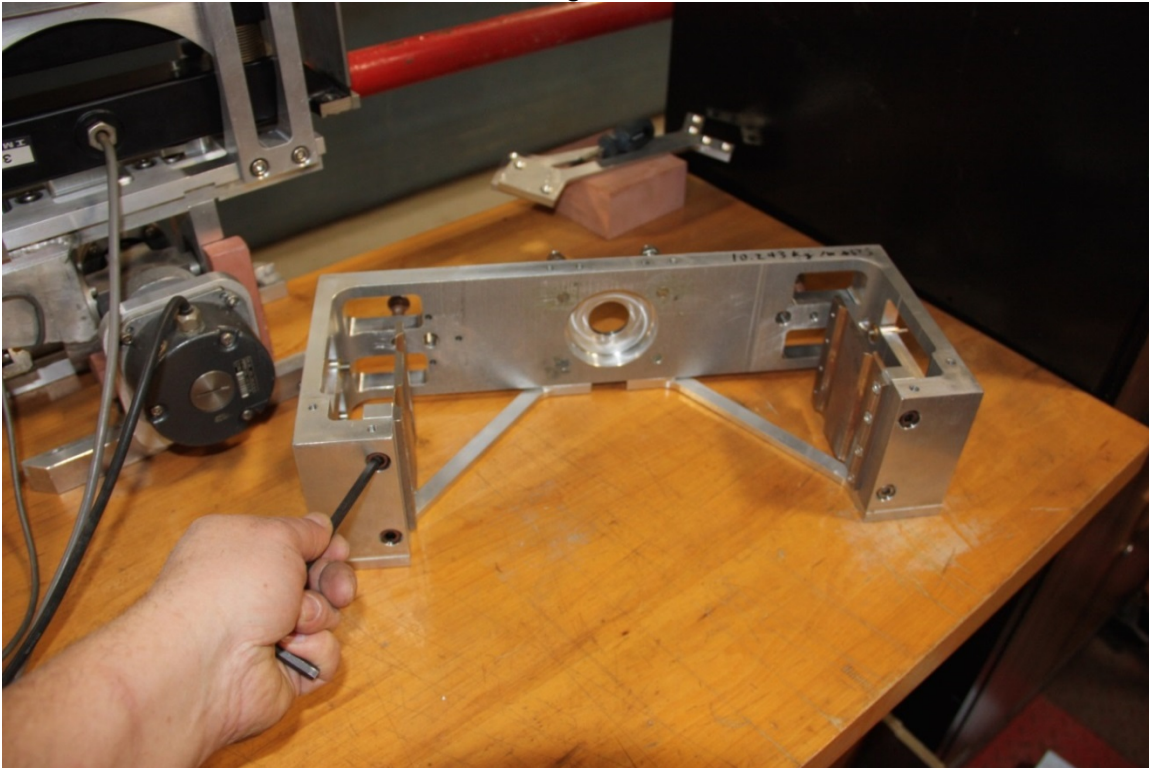

2) Block gimbal U-joint for installation (See Appendix A.)

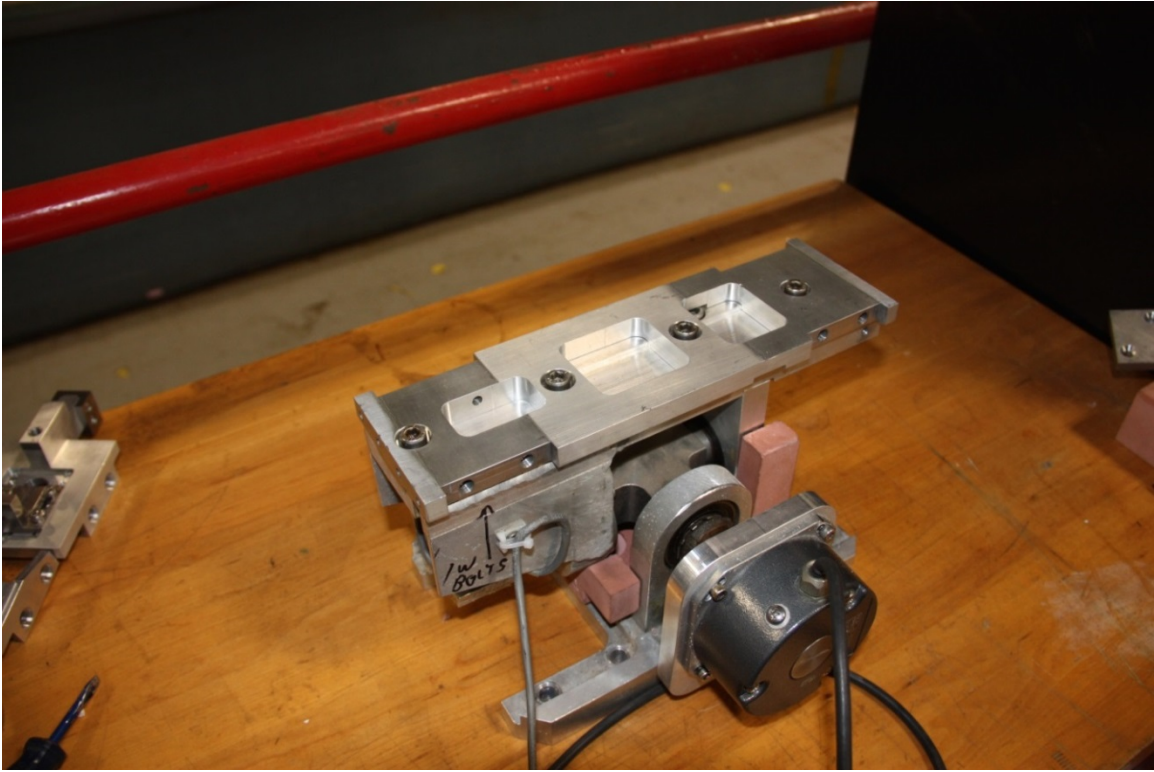

3) Interface SM Brackets required

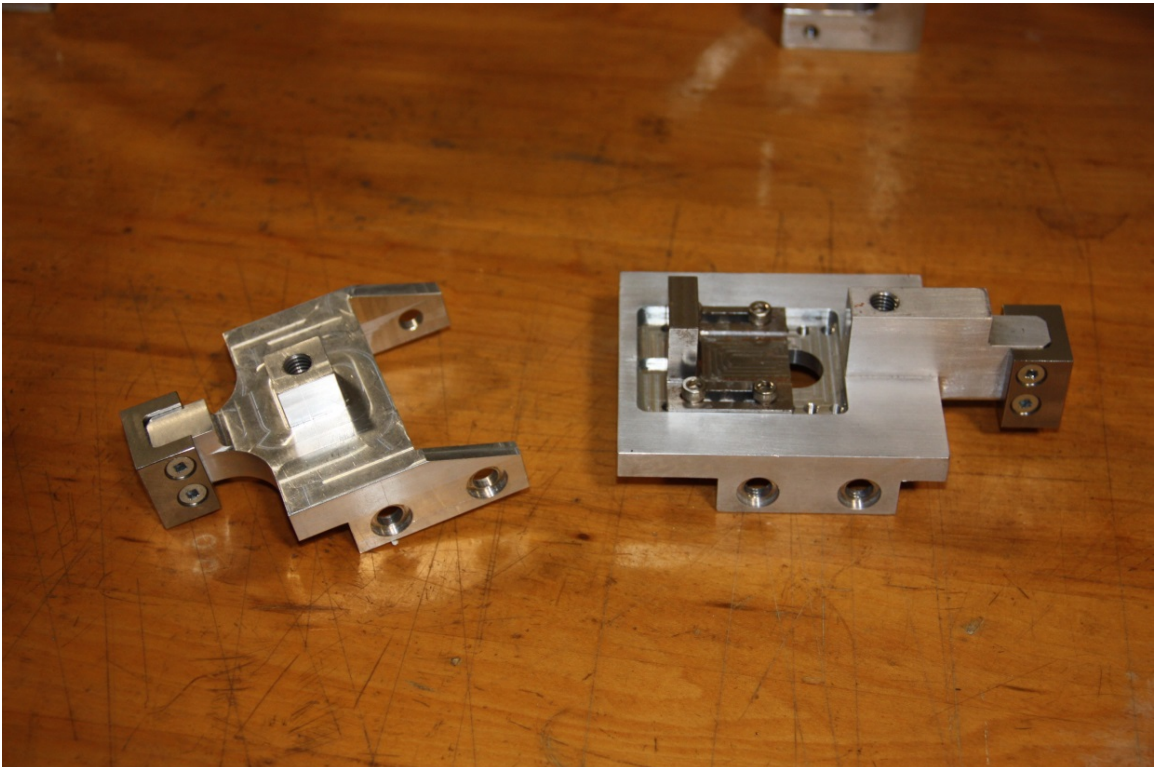

- 4) Install flex link bracket on gimbal in orientation shown:

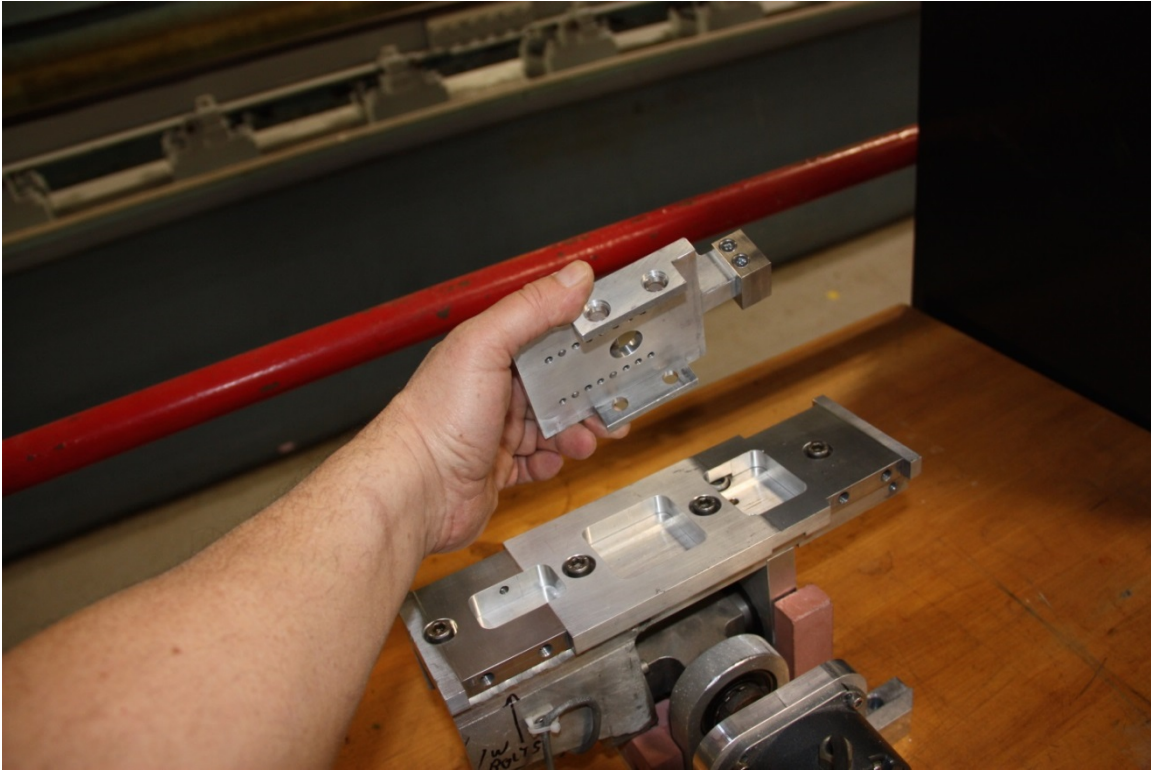

- 5) Install Load cell bracket on gimbal as orientation below:

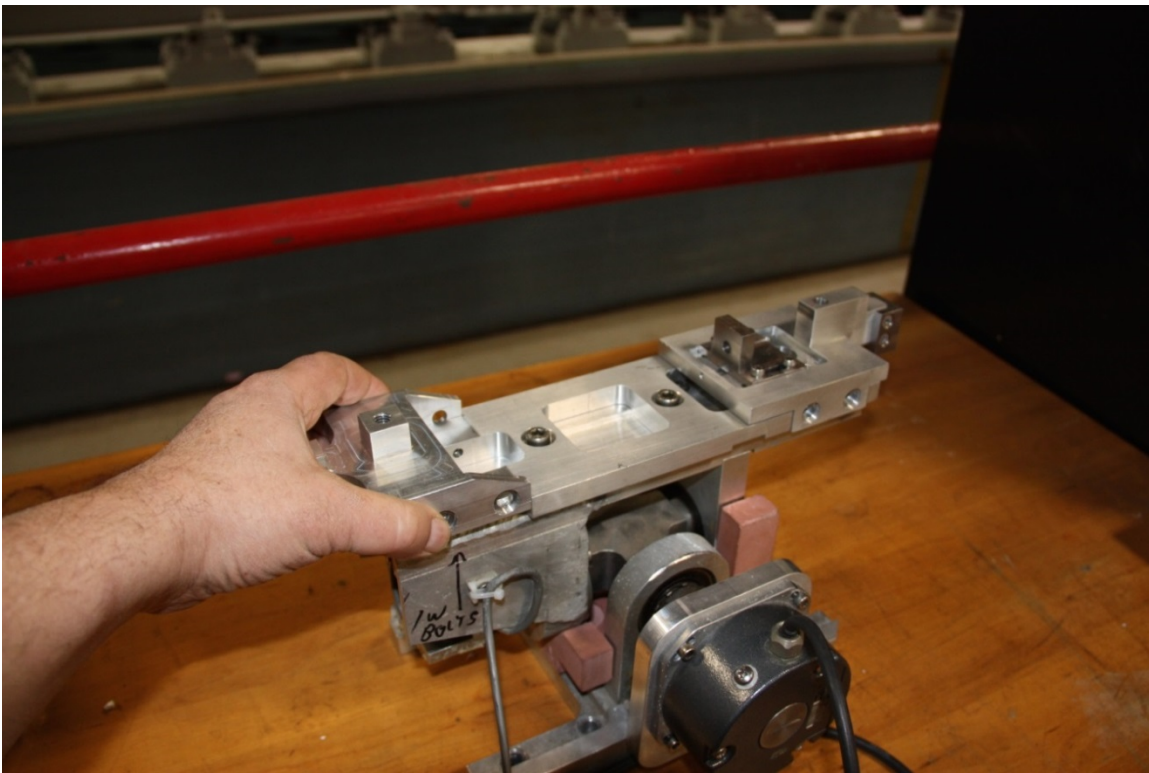
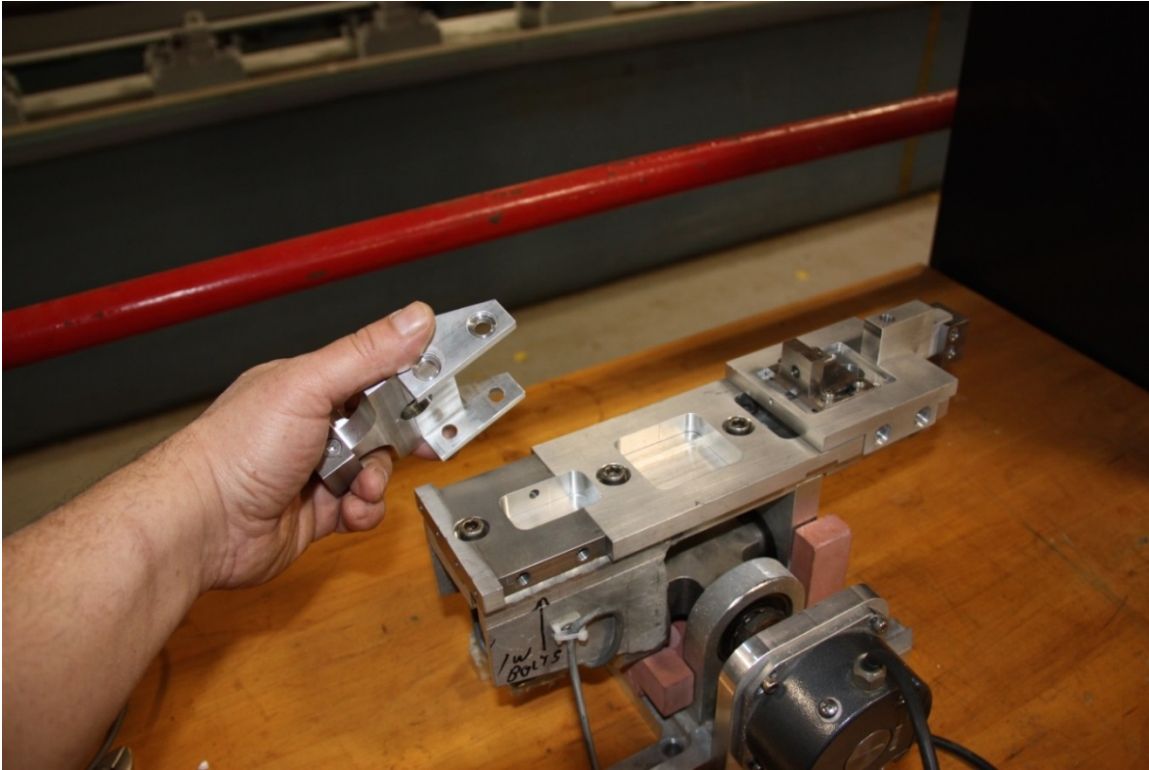

- 6) Install (8) cap screws size: 5/16-18-1/2 and set aside

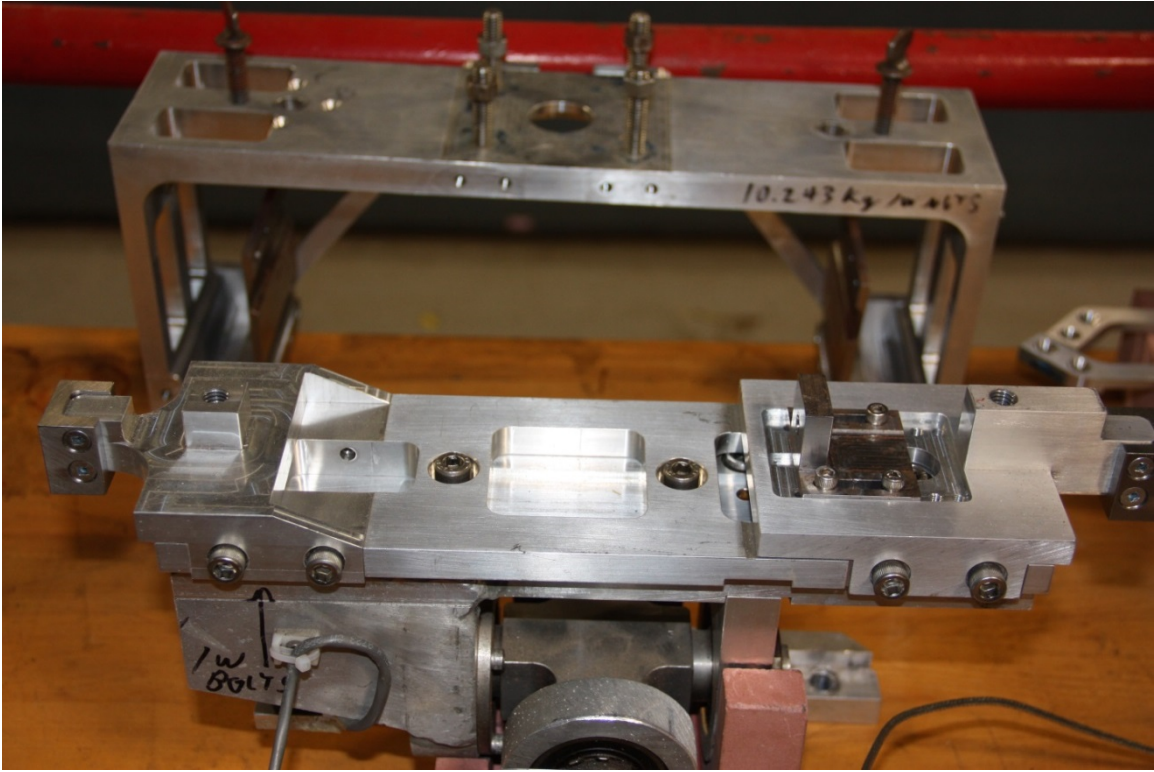

- 7) A) Connect the mounting block to the Interface SM load cell with countersunk hex screw size: 1/4-20-1/2(ensure the load cell body is running parallel with the mount and the wire is on the grounded or dead side) using (1) countersunk hex size:

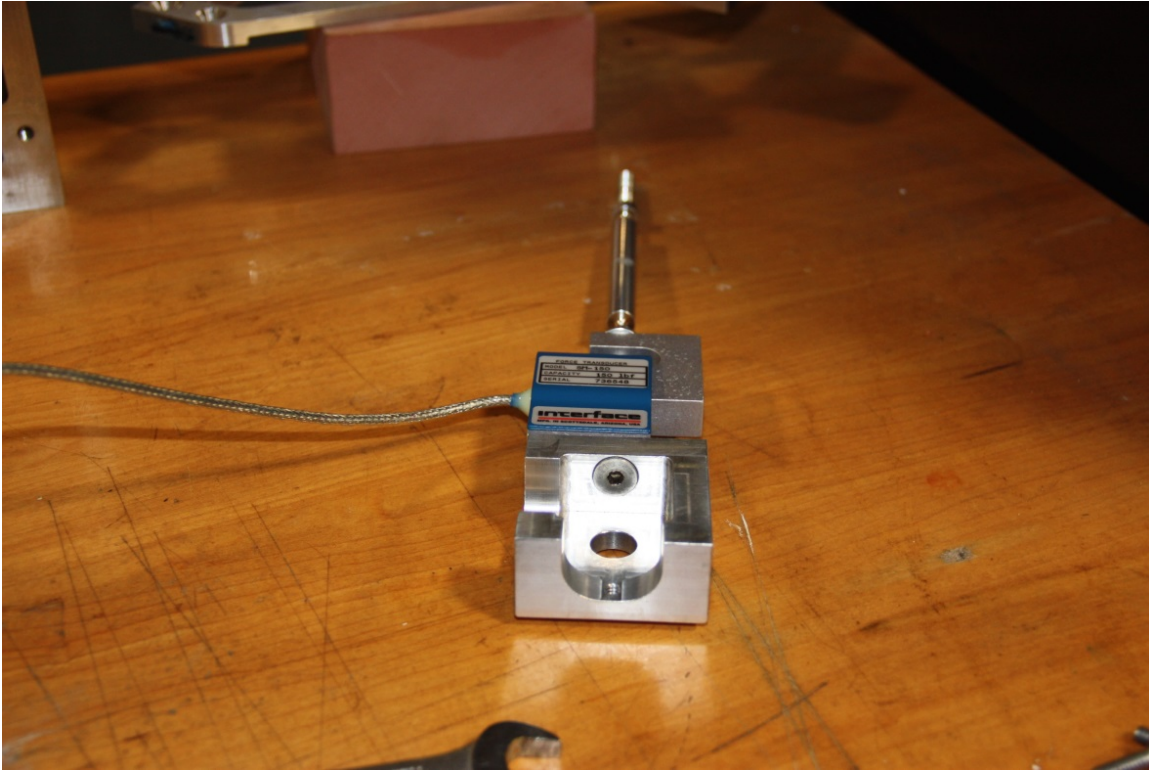

B) Connect the live side of the load cell to the flex link (**ensure that the washer spacers are in the correct place as noted when disassembled**) else see: Procedure 3

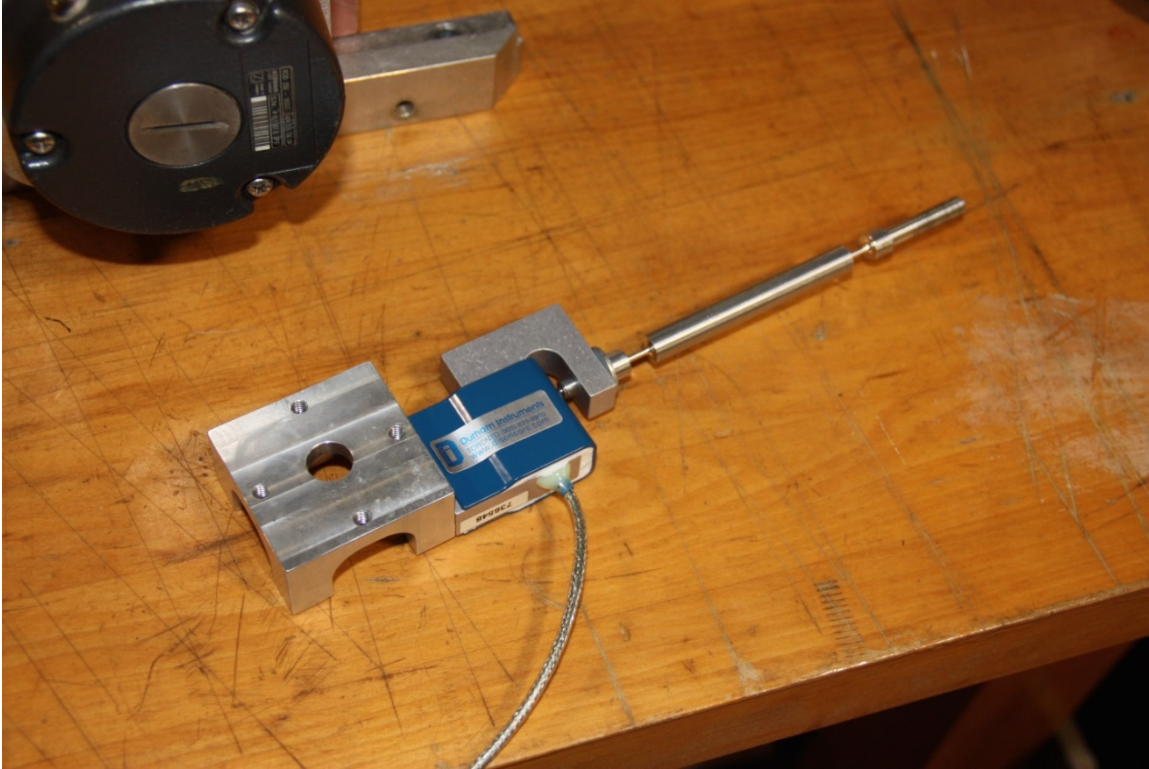

- 8) Place the load cell assembly on the live side of the dyno gimbal with the flex link through its mount

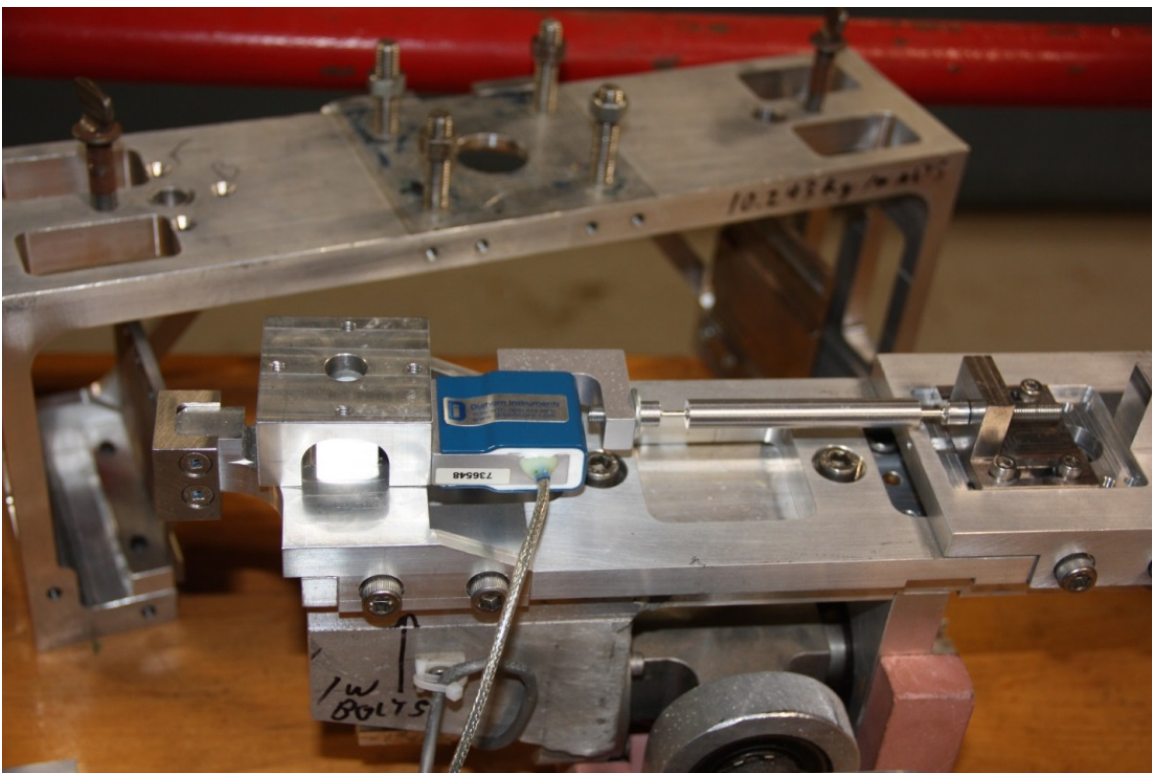
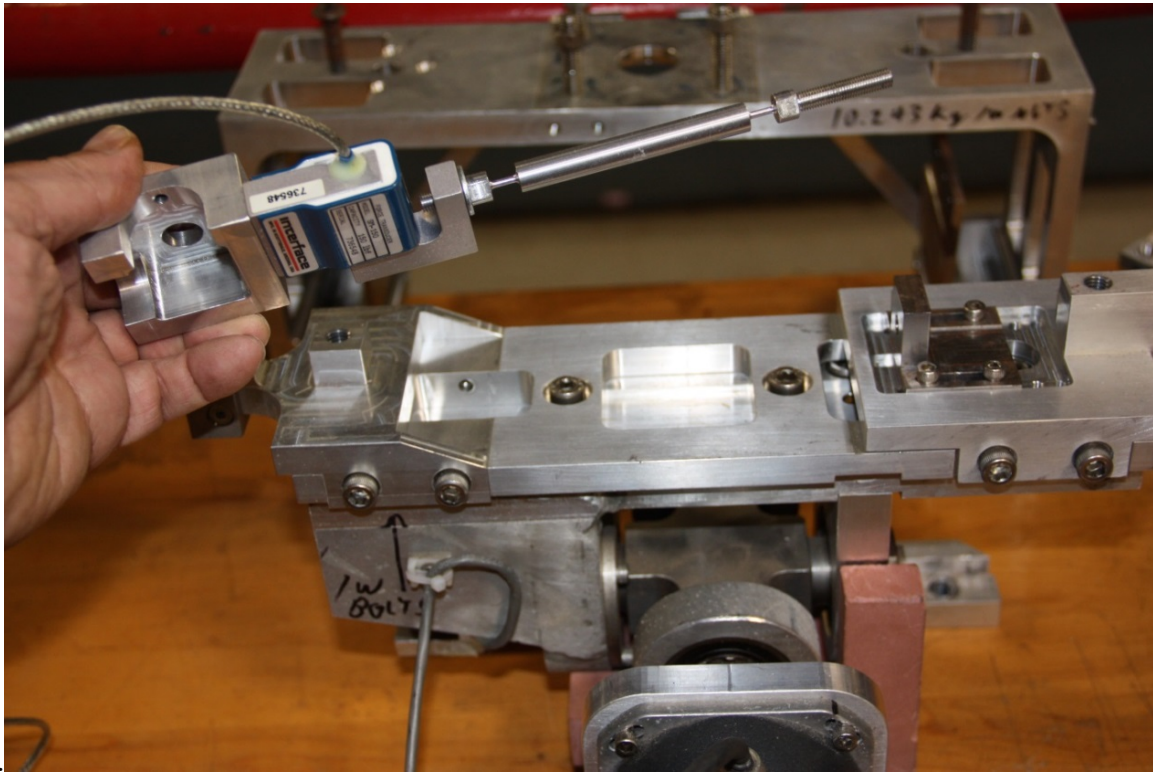

- 9) Put the loadcell blocking spacers in place. See Appendix B

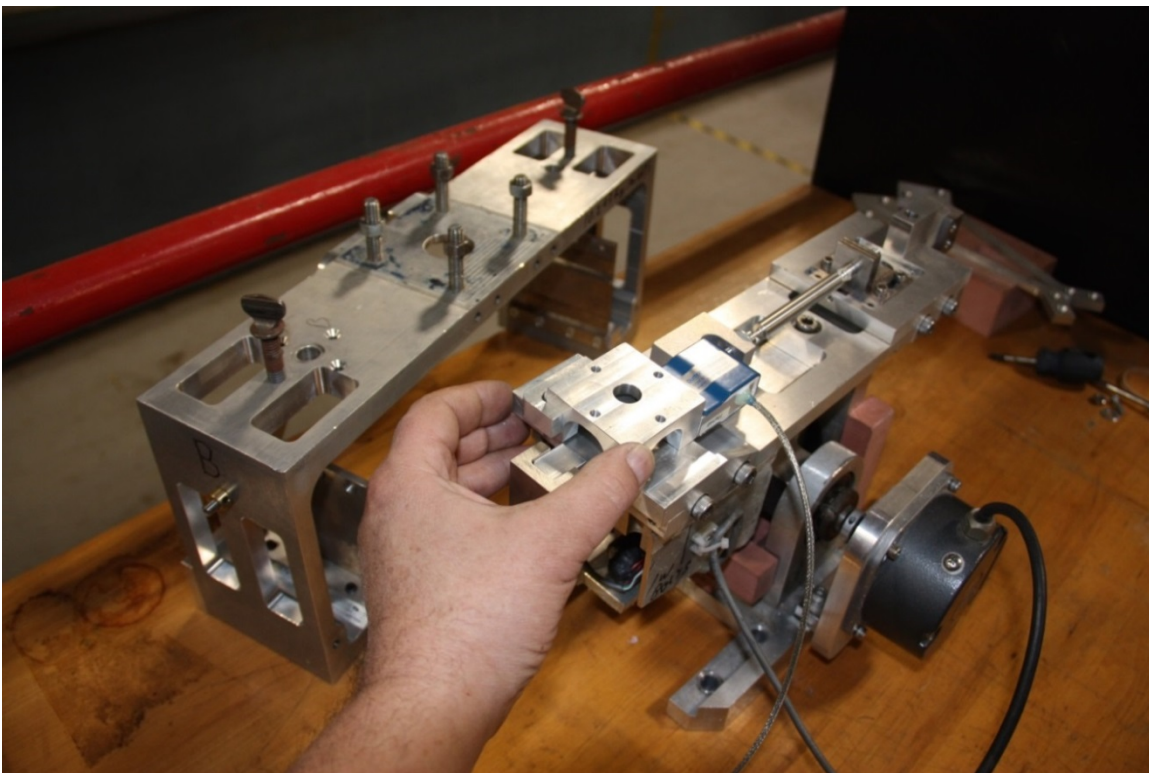
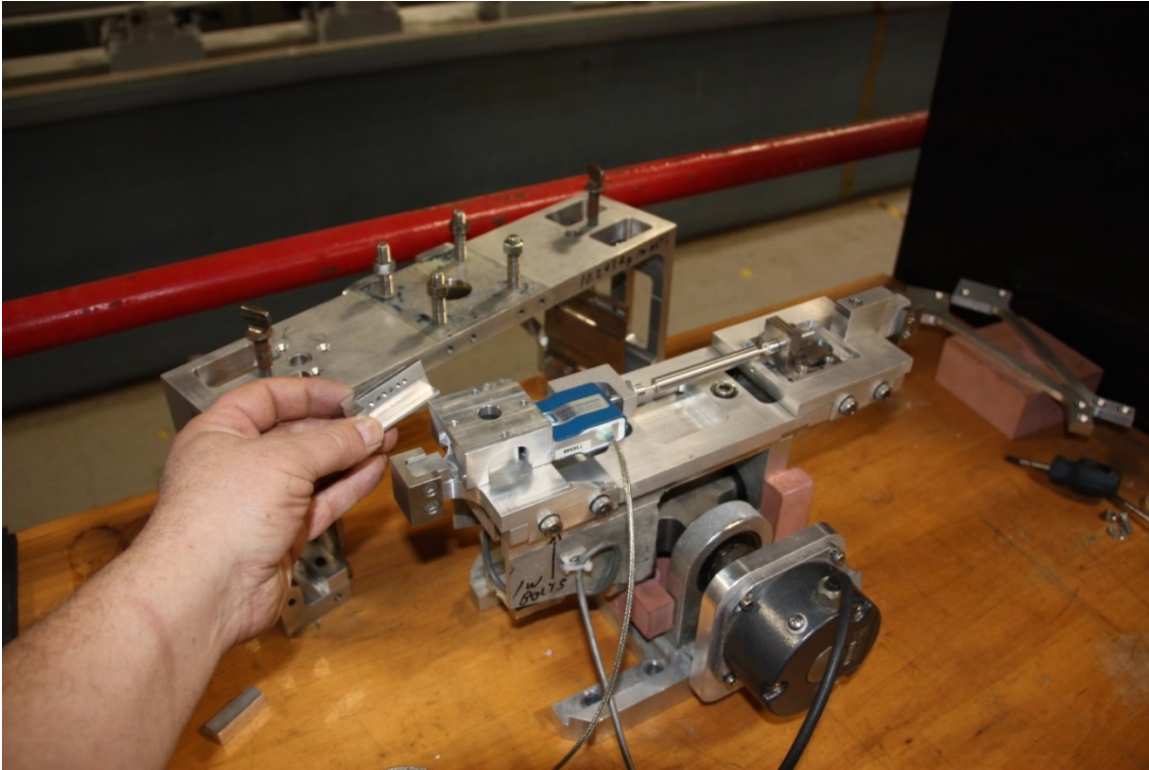

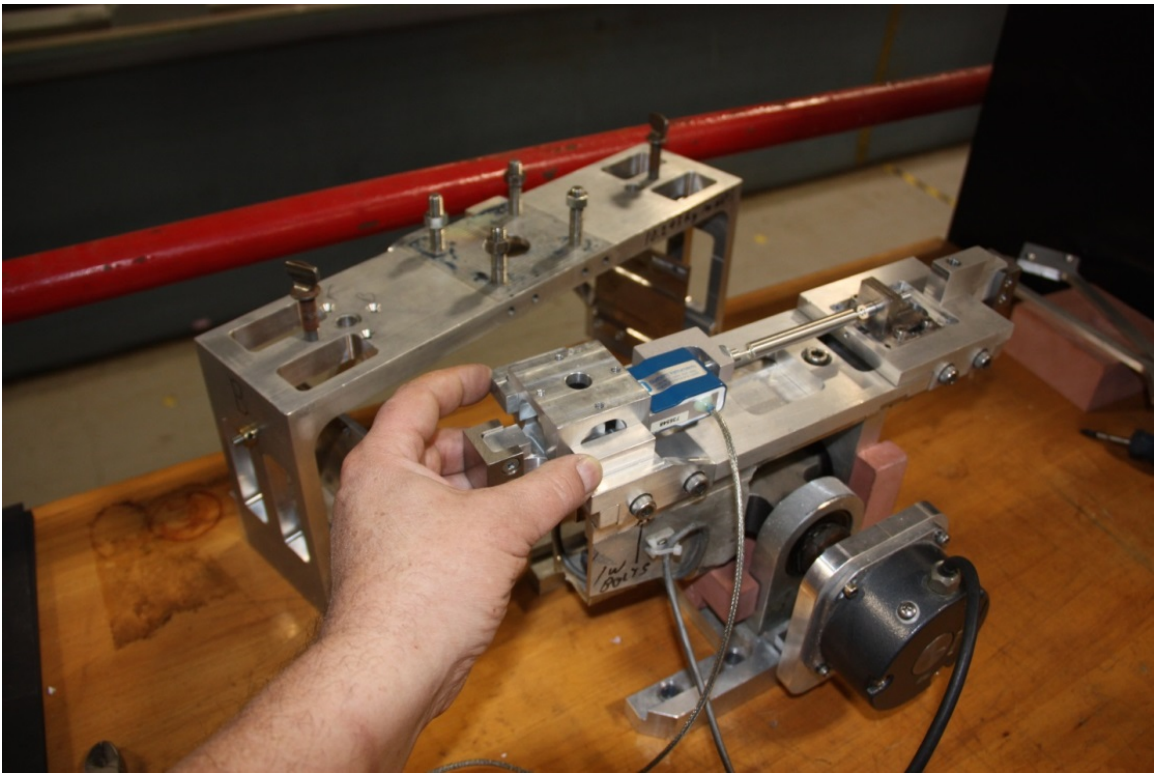
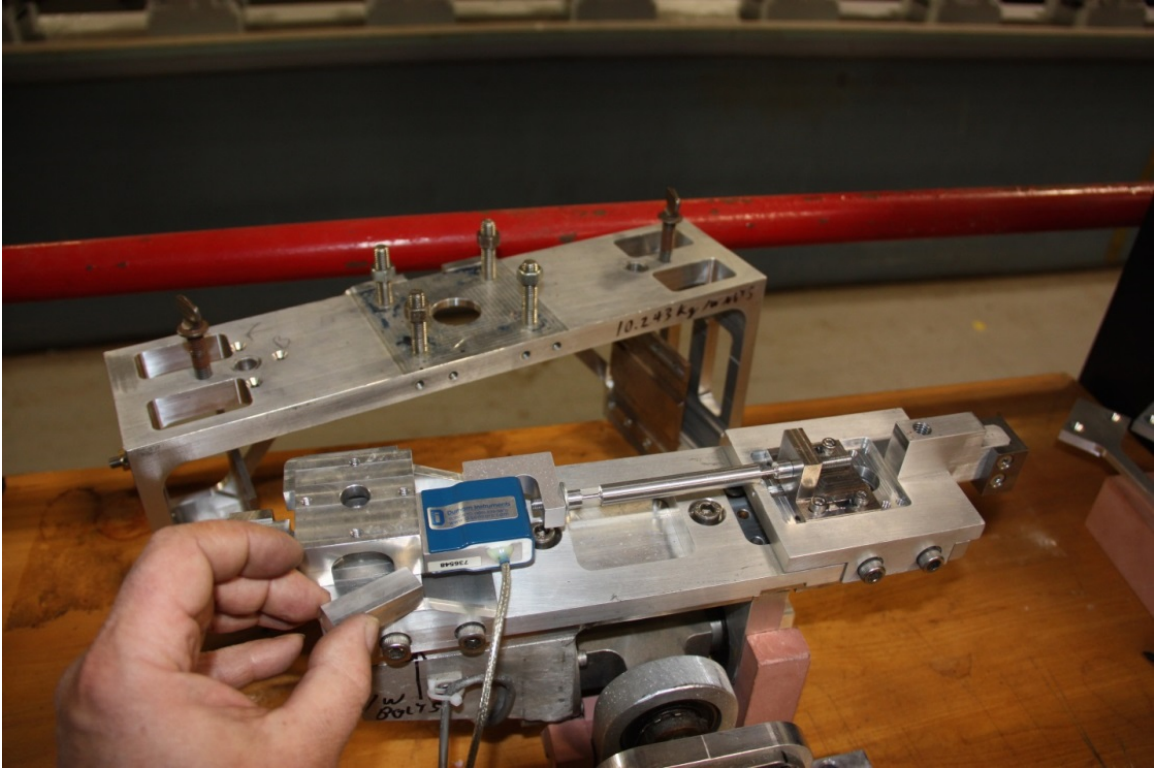

- 10) An elastic band will aid in keeping the unit together.

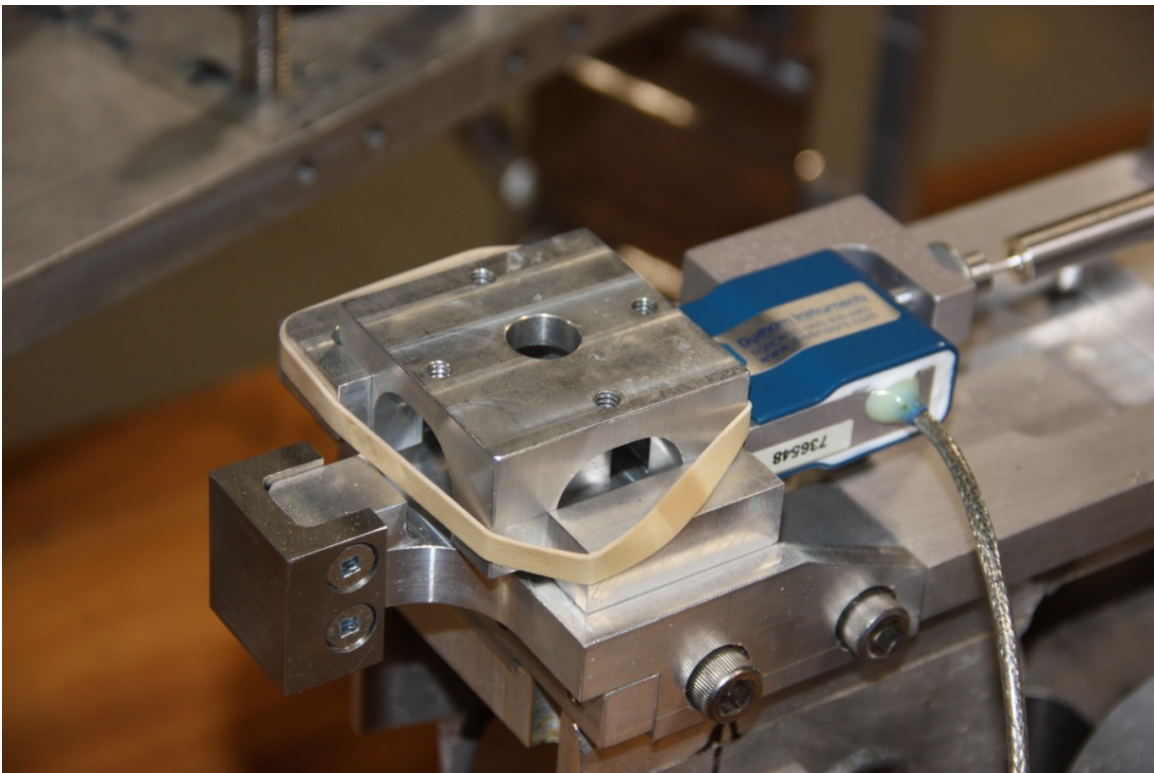
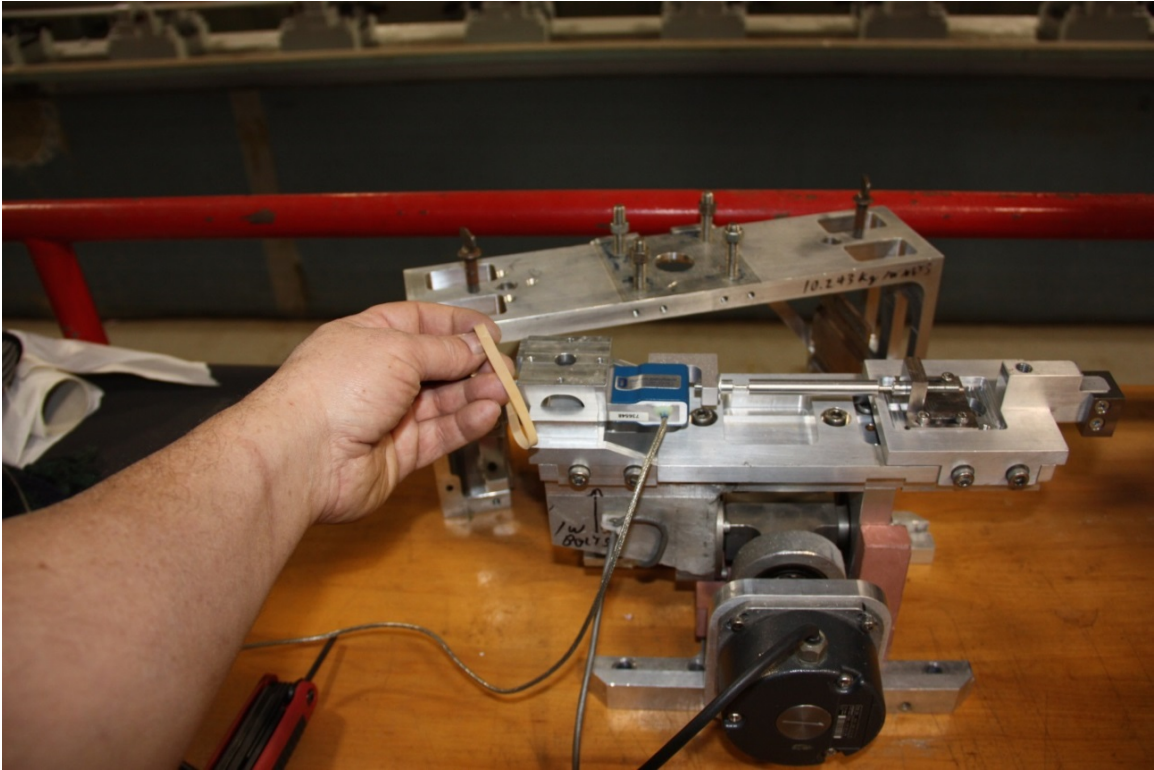

- 11) Install and tighten the $\frac{1}{4}$ -28 nut on the flex-link

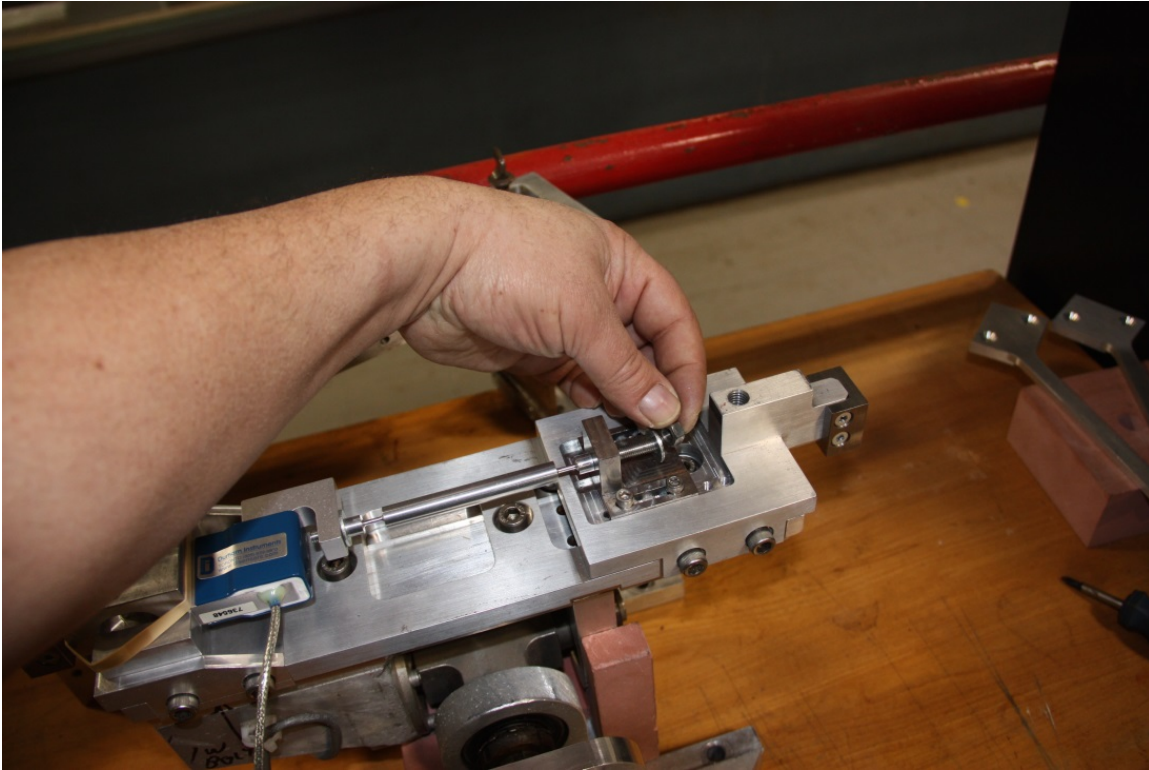

- 12) Check the load cell mount is fitting properly in the block spacers and the spacers are fitting correctly to the dyno live side. If there are visible gaps the flex link washer spacers are not in the correct position and need to be fixed to the correct position, or see **Trouble shooting: Load cell flex link adjustment**. Then tighten flex link nut size:. **DO NOT TWIST FLEX LINK.**

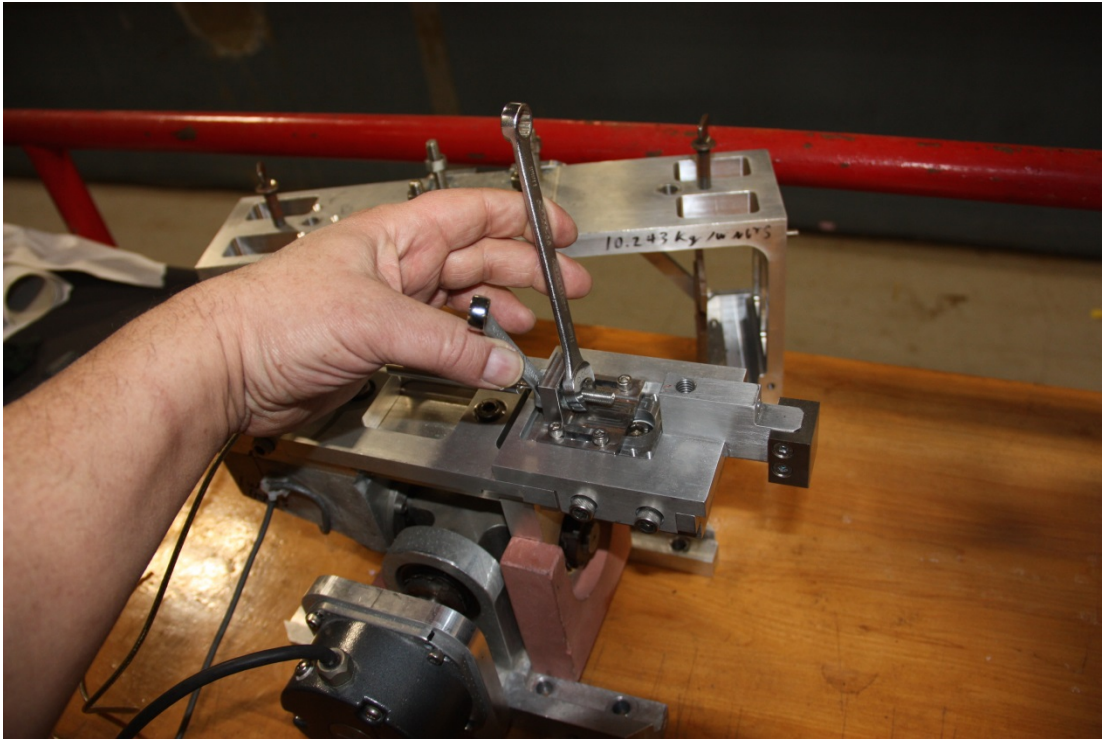

- 13) Carefully slide the outer housing on over the assembly until centered. (Blocking the outer housing may help with flex plate hole alignment)

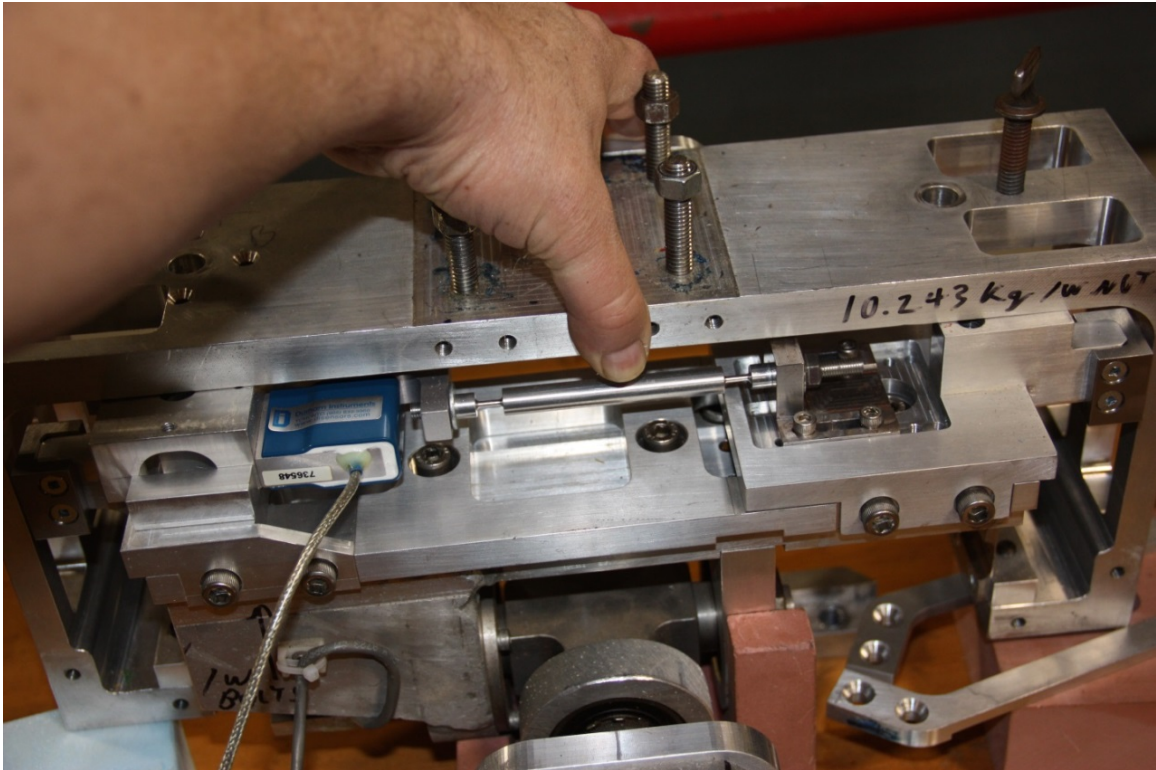

- 14) Install all the counter sunk Robinson screws size: #10-24-1/2 fastening the flex plates to the dyno live side

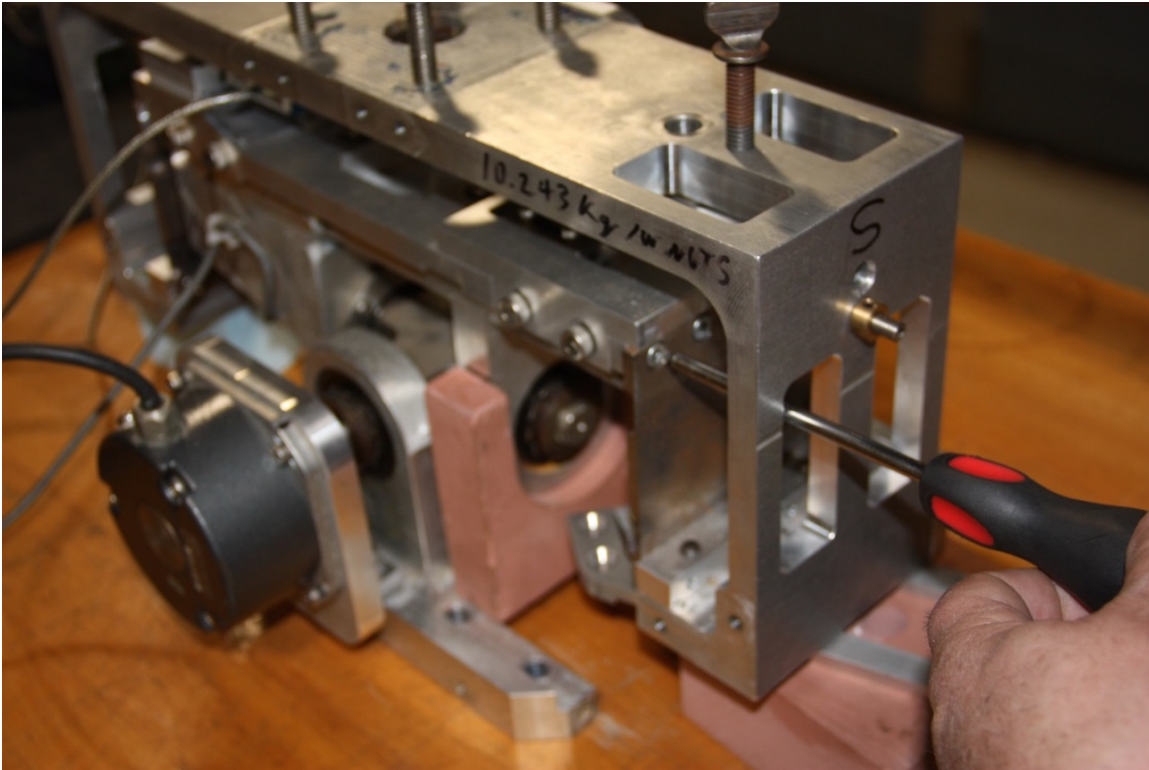

Gently tighten the screws.

- 15) Install the screws size: #10-24-3/4 to fasten the load cell mount to the dead side of the dyno. If the holes do not align then the flex link was incorrectly installed and needs to be corrected. See: Load cell flex link adjustment

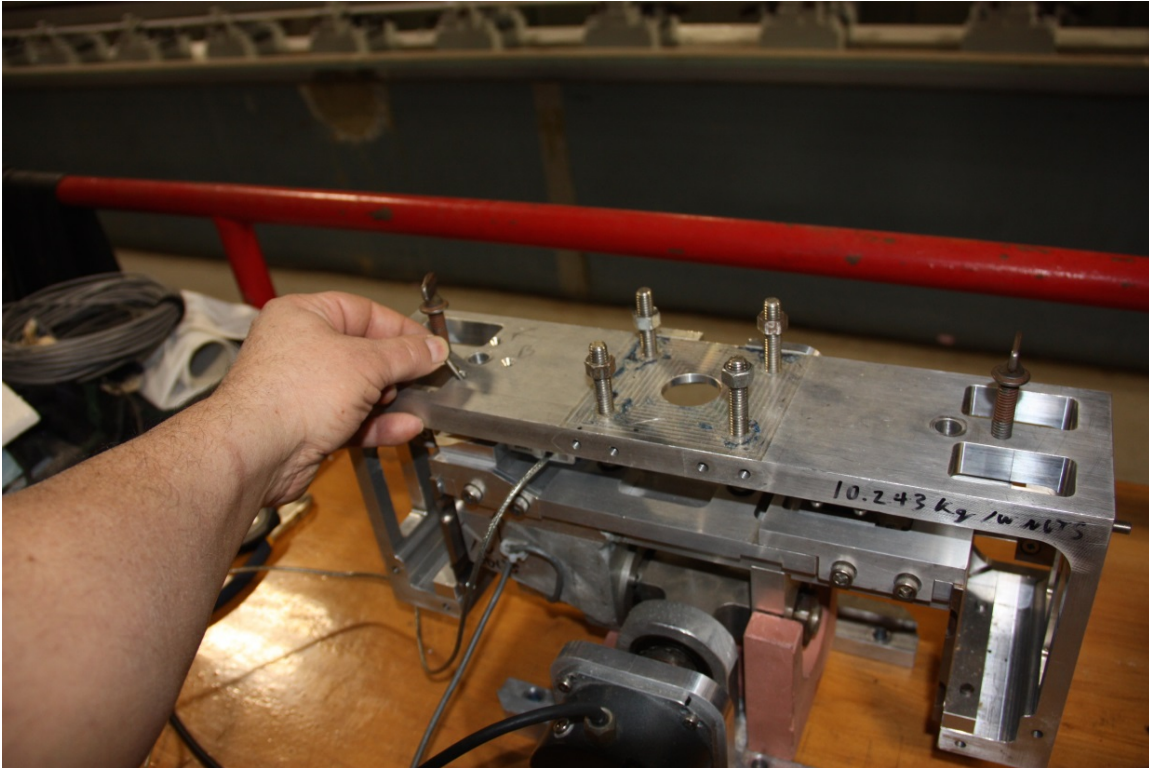

16) Cut remove elastic band and two spacer blocks.

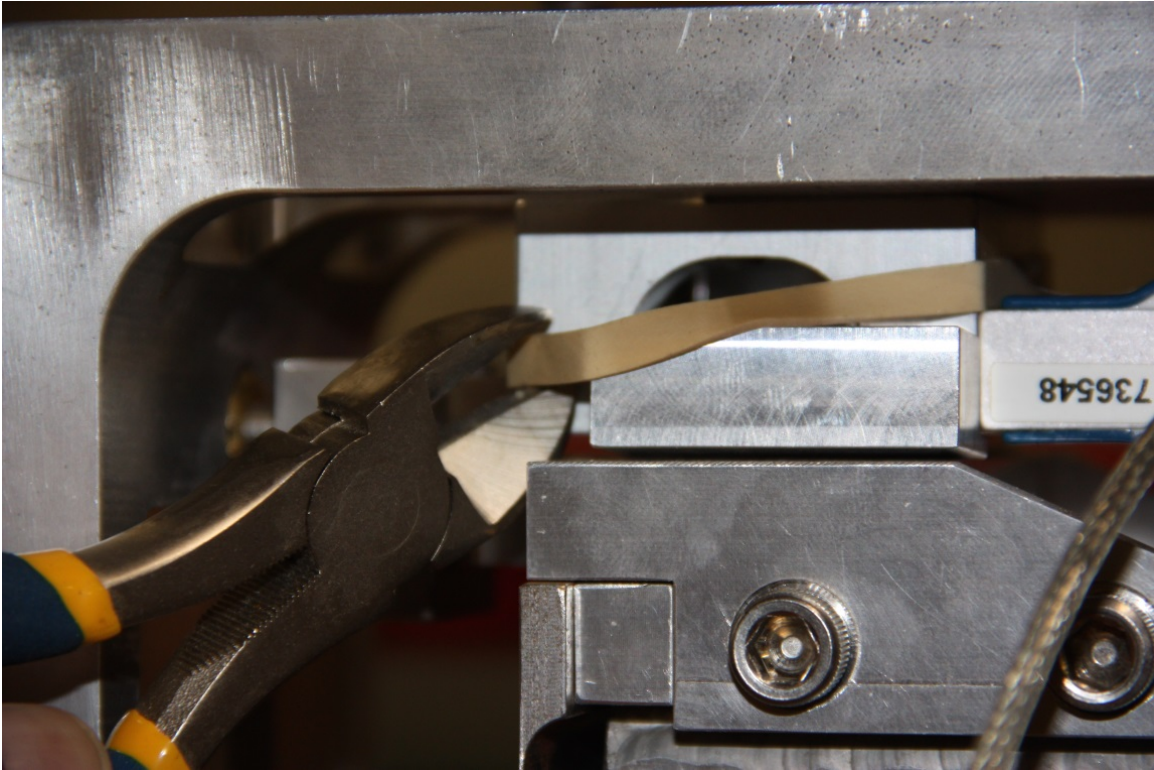

17) Carefully adjust alignment of unit and tighten the (4) Flex plate hex bolts

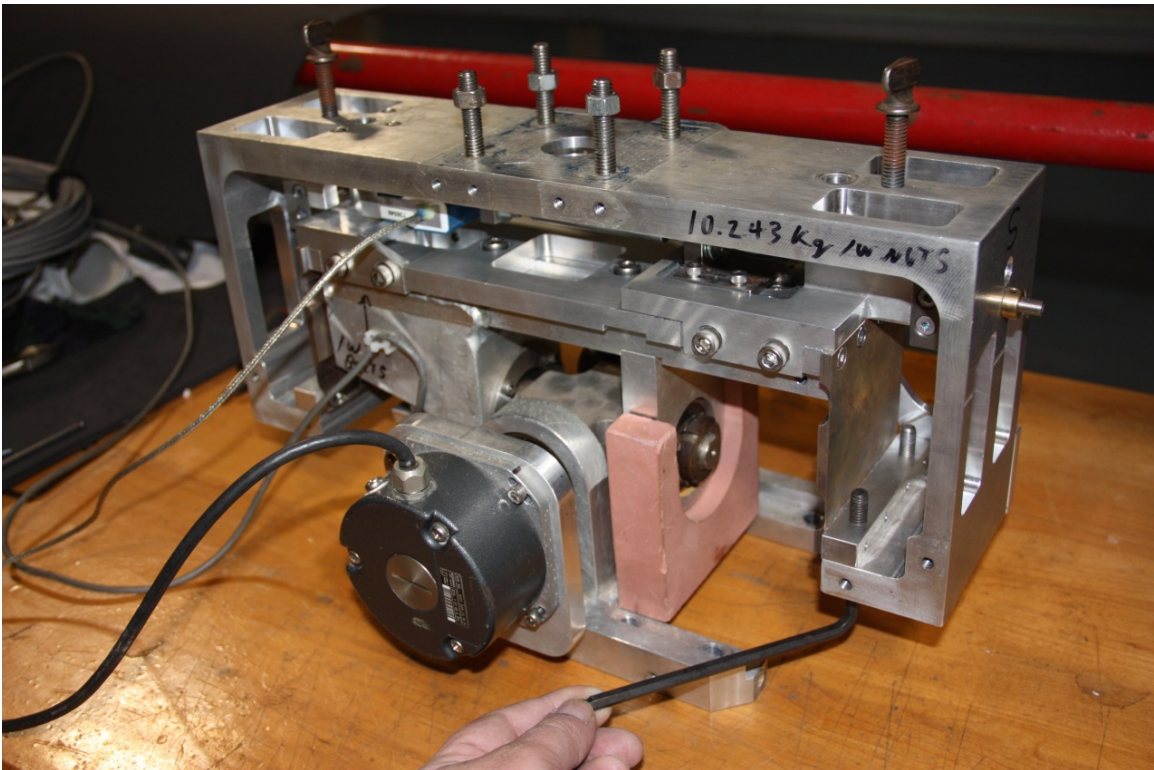

- 18) Install the two braces from the dyno outer frame using (8) countersunk hex size: $\frac{1}{4}$ -20-1/2

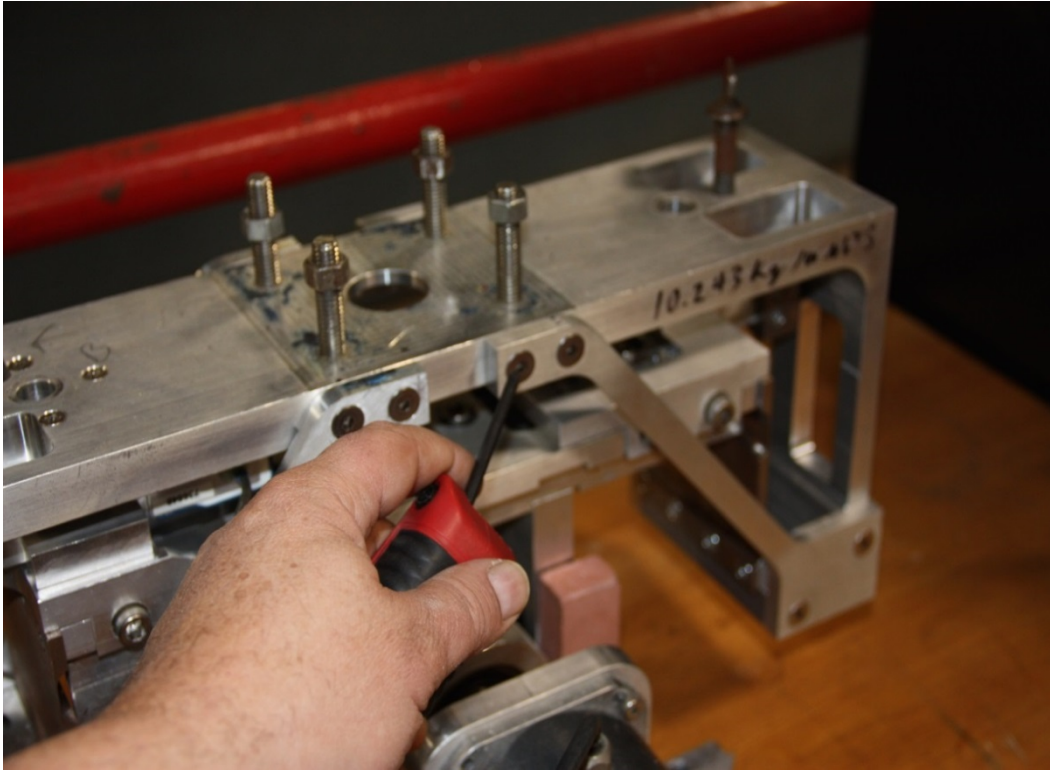

Dyno assembled ready for calibration. See Appendix C for setting limit stops

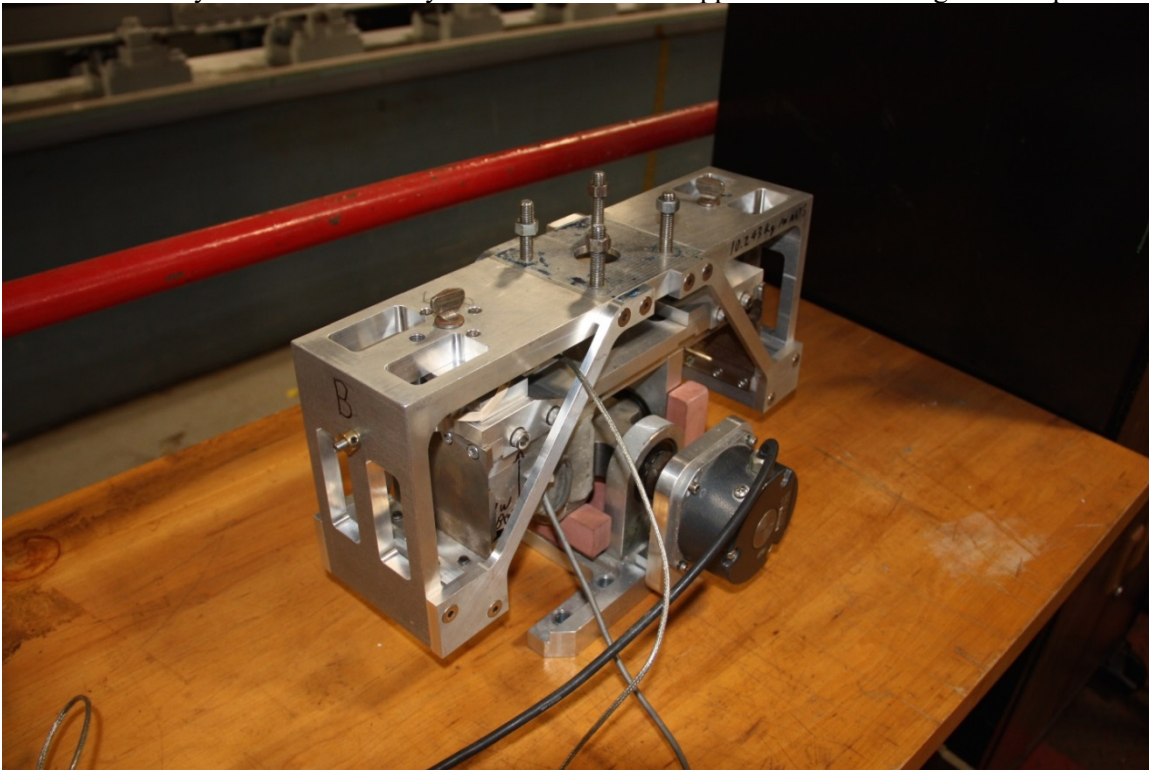

B.1 Troubleshooting

B.1.1 Load Cell Flex link Adjustment Procedure

The only time this procedure should have to be undertaken is if the flex link has to be replaced, washer spacers were lost/changed, the load cell blocking spacer adjustment slipped or the form factor of the load cell is not of the Interface Technology SM design. Check to make sure the spacer washers are in the correct configuration as below.

Determine which of the issues above is most likely then follow procedure for most likely case

Proceed with assembly or disassembly to get the outer dyno shell removed as below

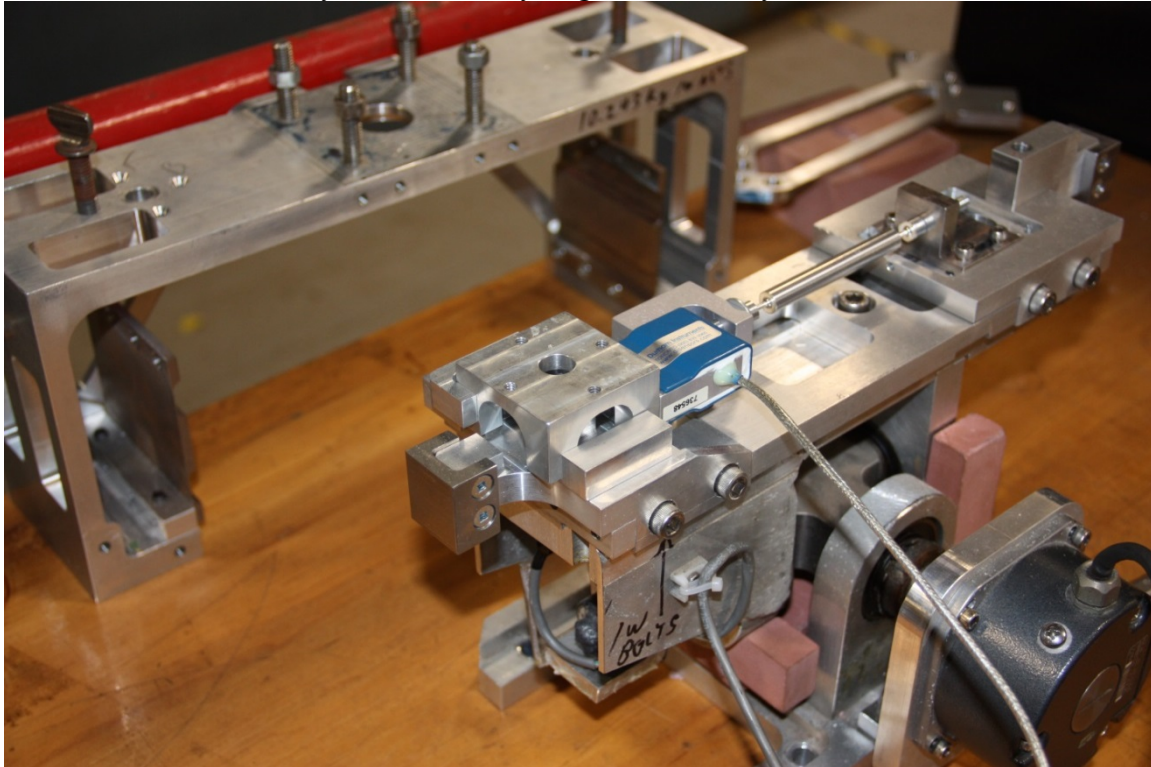

B.1.1.1 Lost or replaced flex link or washer spacers

A) Loosen the four bolts

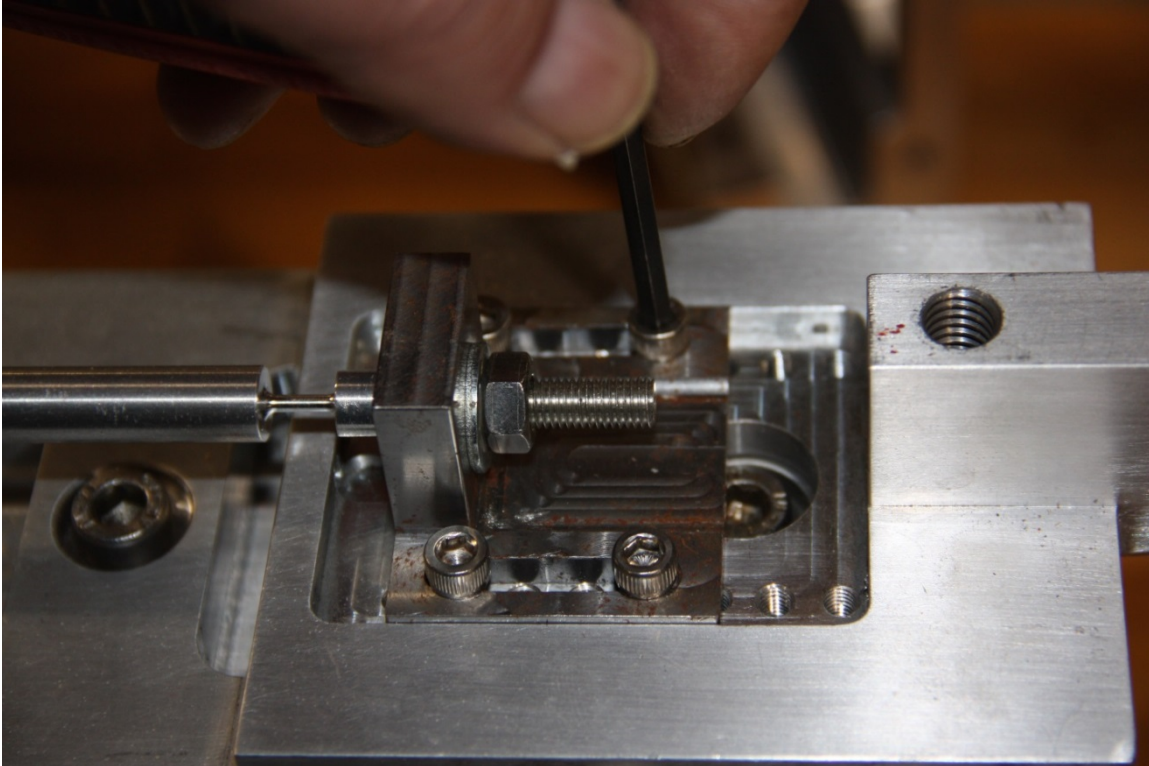

B) Put the loadcell blocking spacers in place.

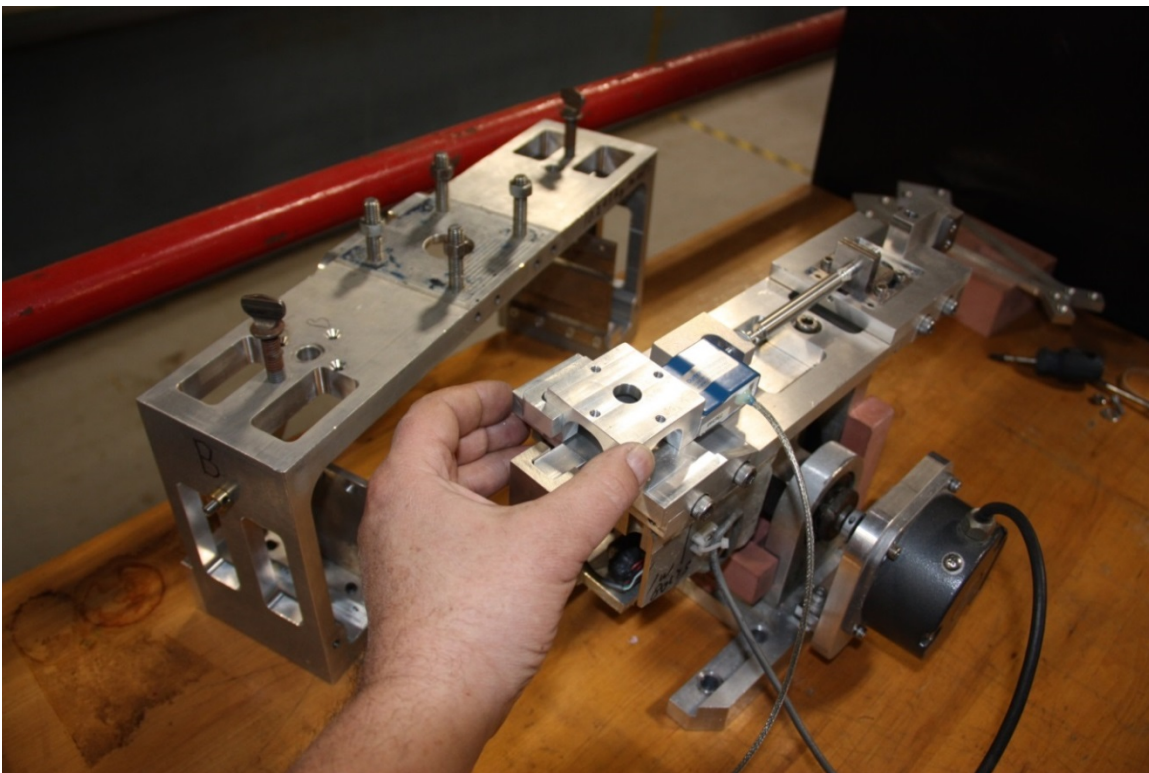
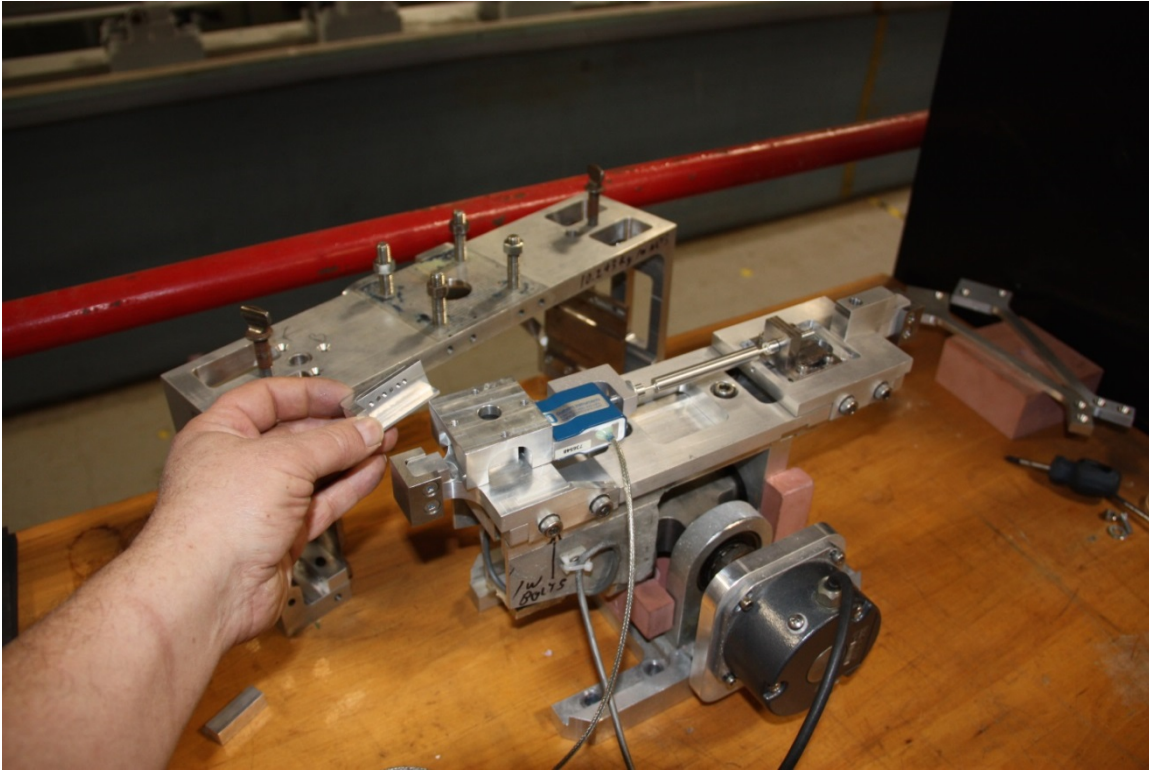

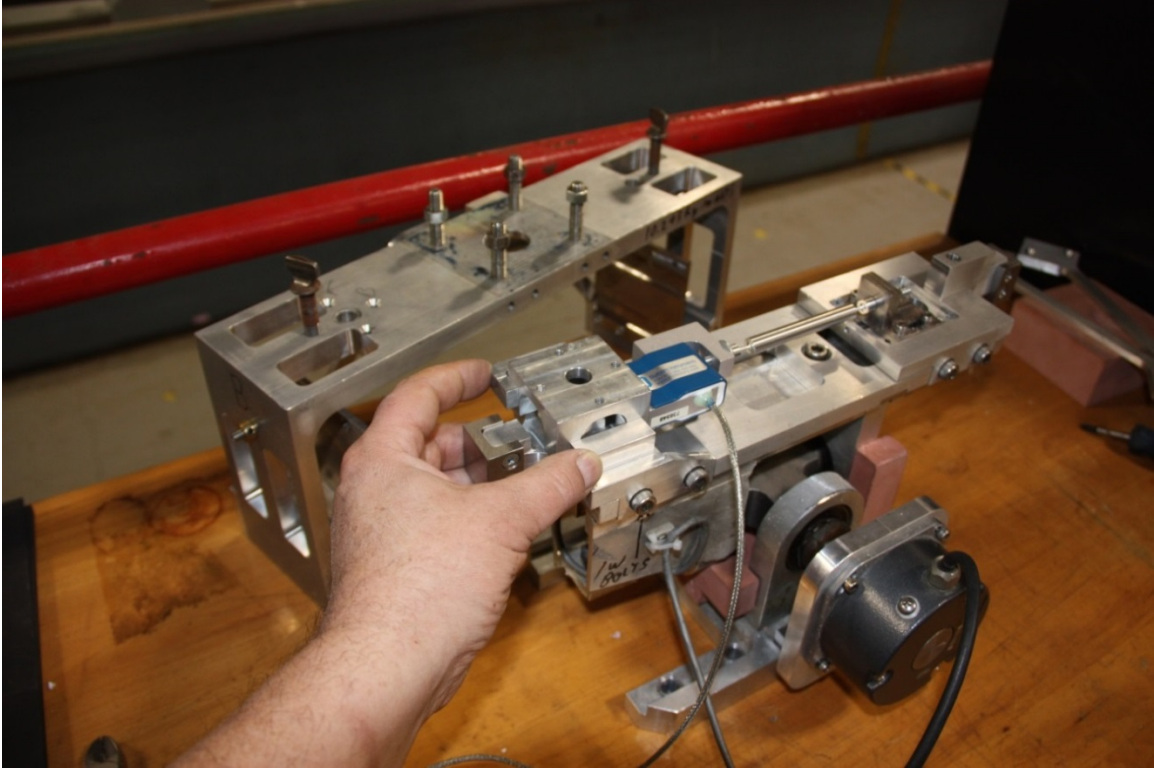
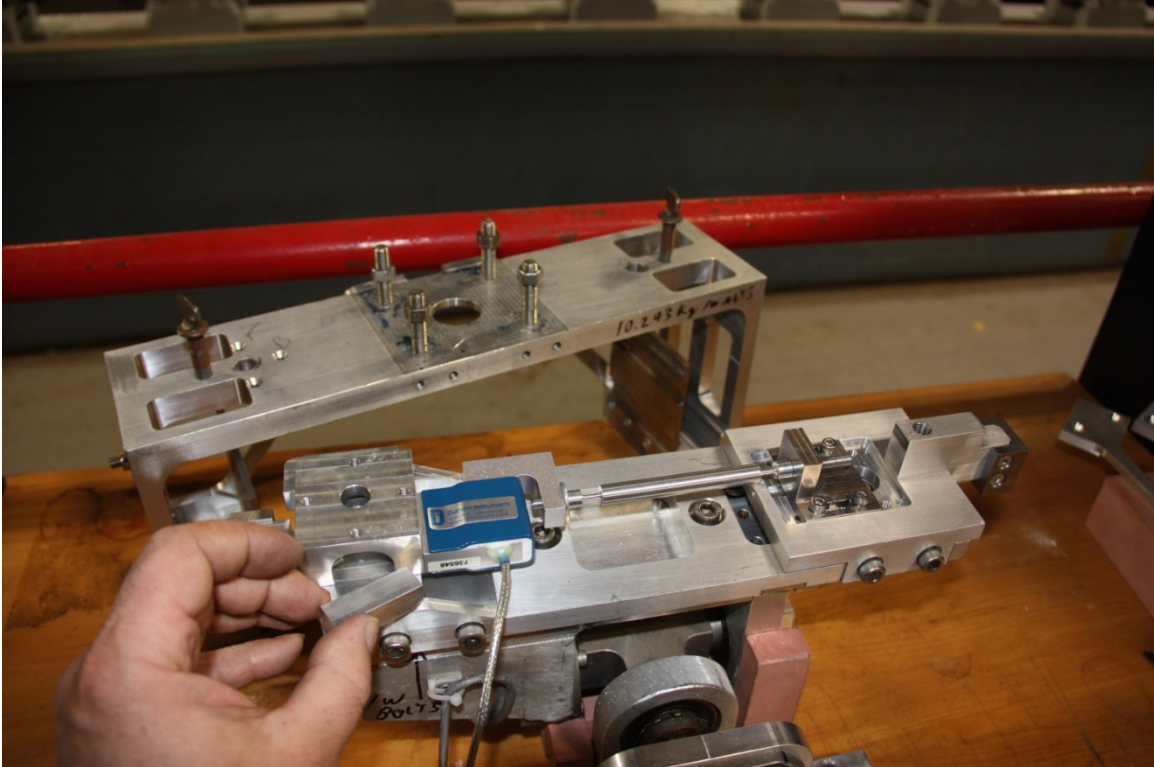

An elastic band will aid in keeping the unit together.

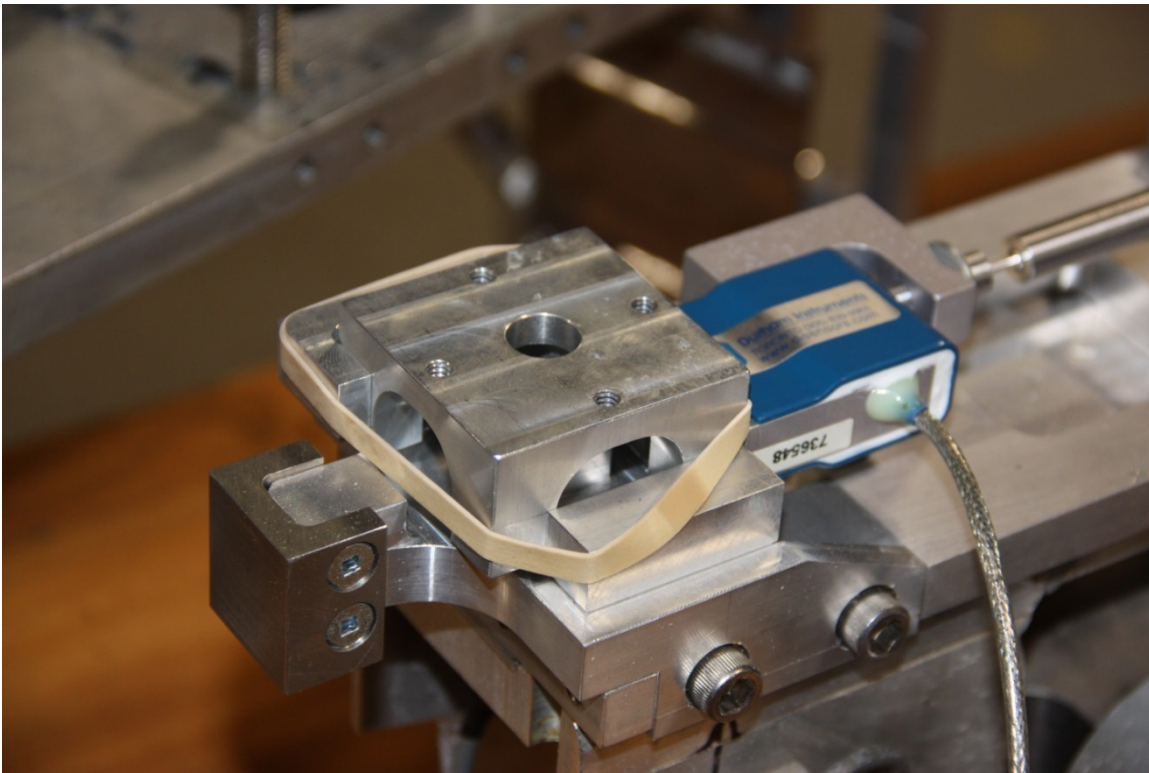
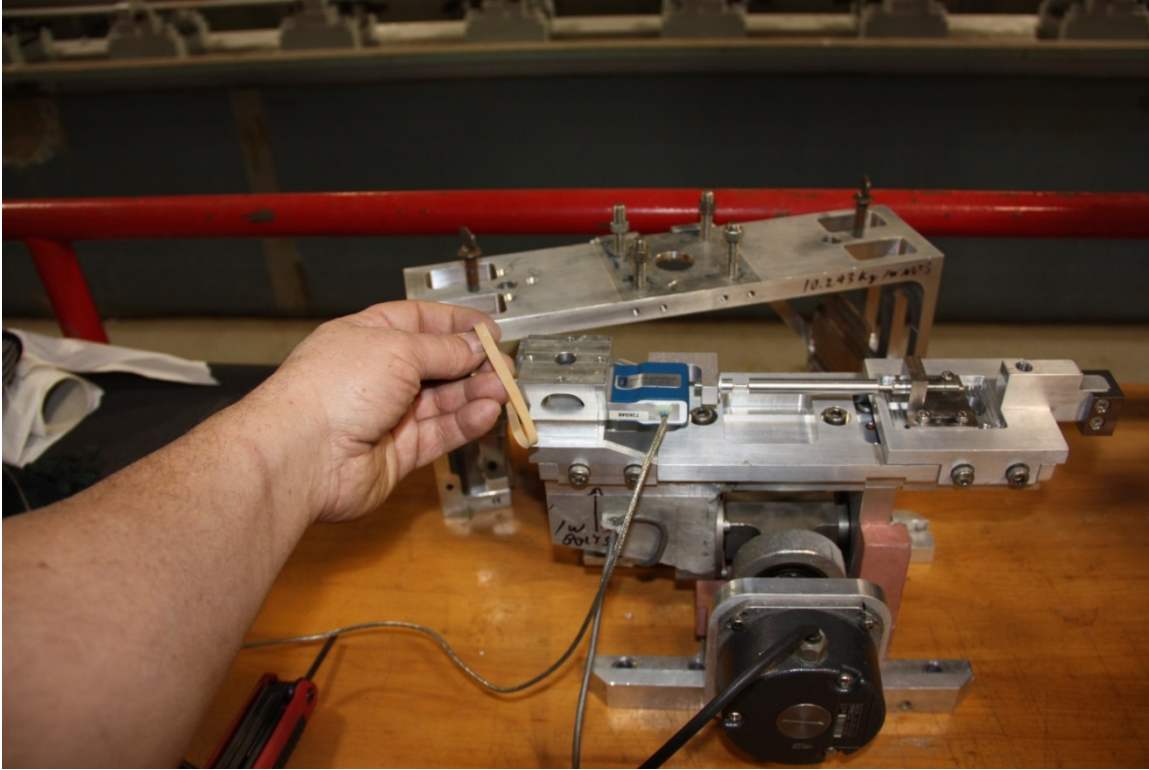

Ensure blocking spacer is tight against live side of the dyno and retighten the four bolts

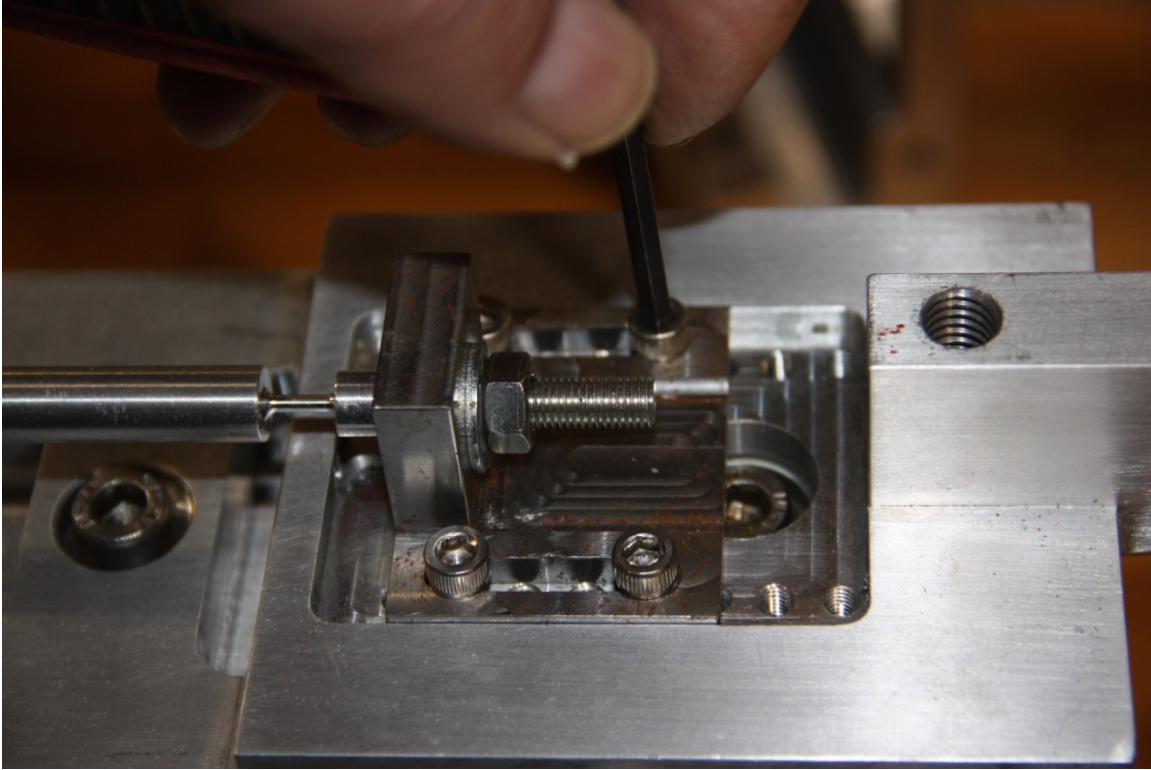

Proceed with reassembly

B.1.1.2 Load cell blocking spacer adjustment slipped

A) Loosen four bolts on flex link attachment

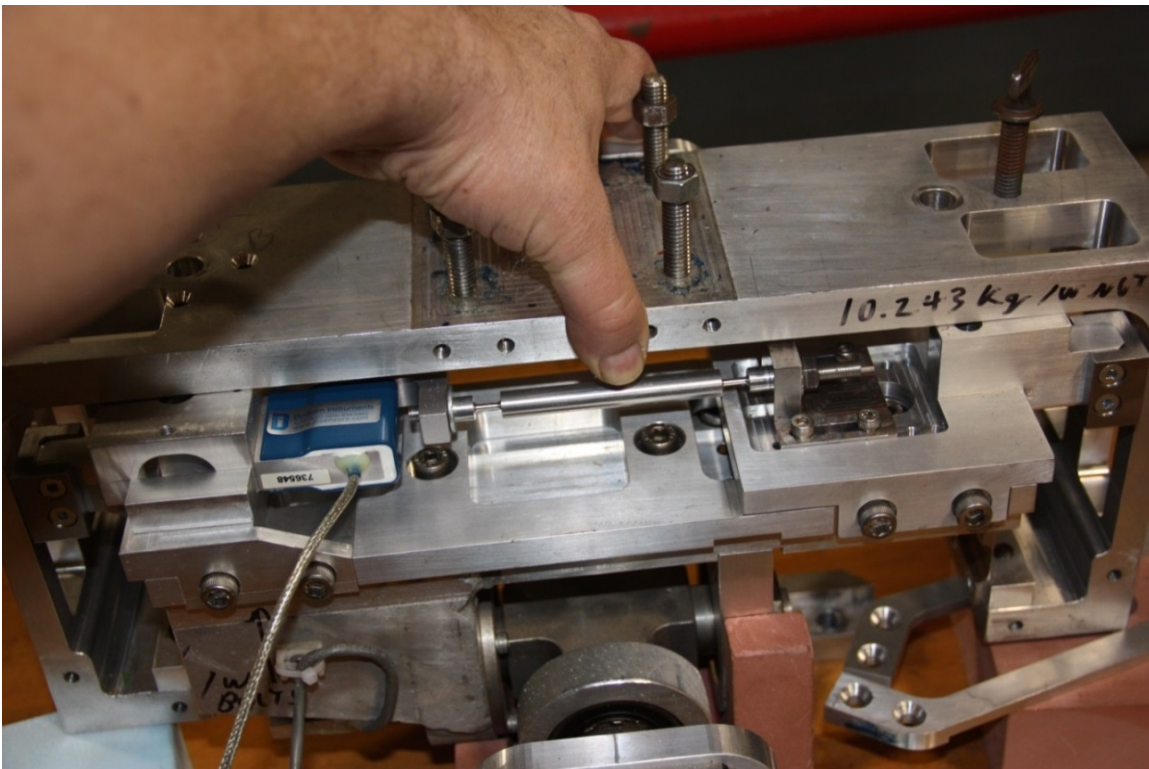
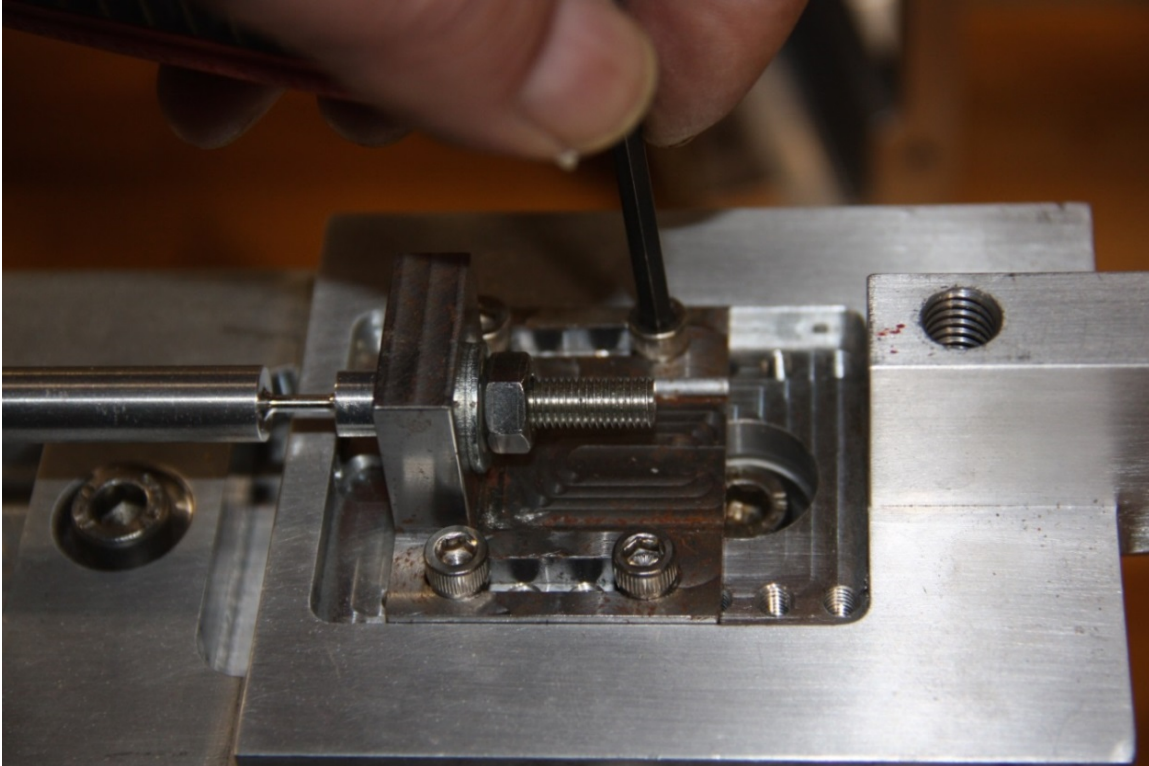

- 1) Install all the screws fastening the flexplates to the dyno live side loosely.

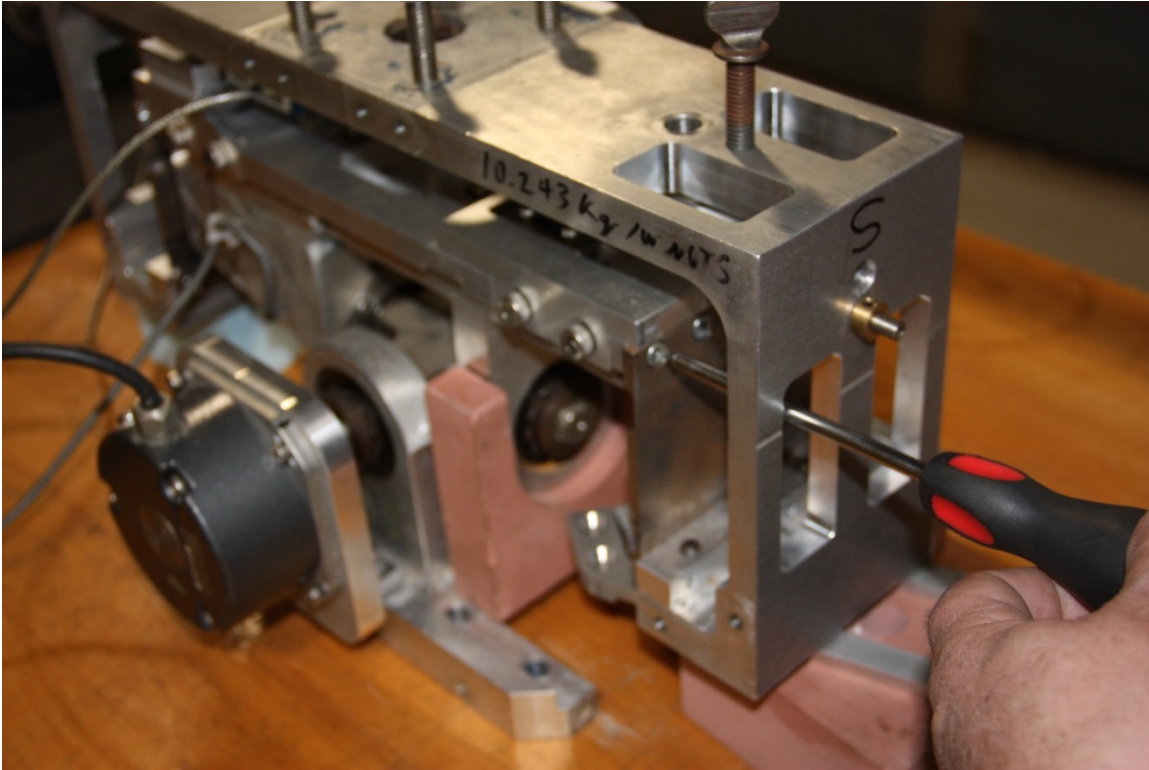

Gently tighten the screws.

- 2) Adjust load cell block and install the screws to fasten the load cell mount to the dead side of the dyno.

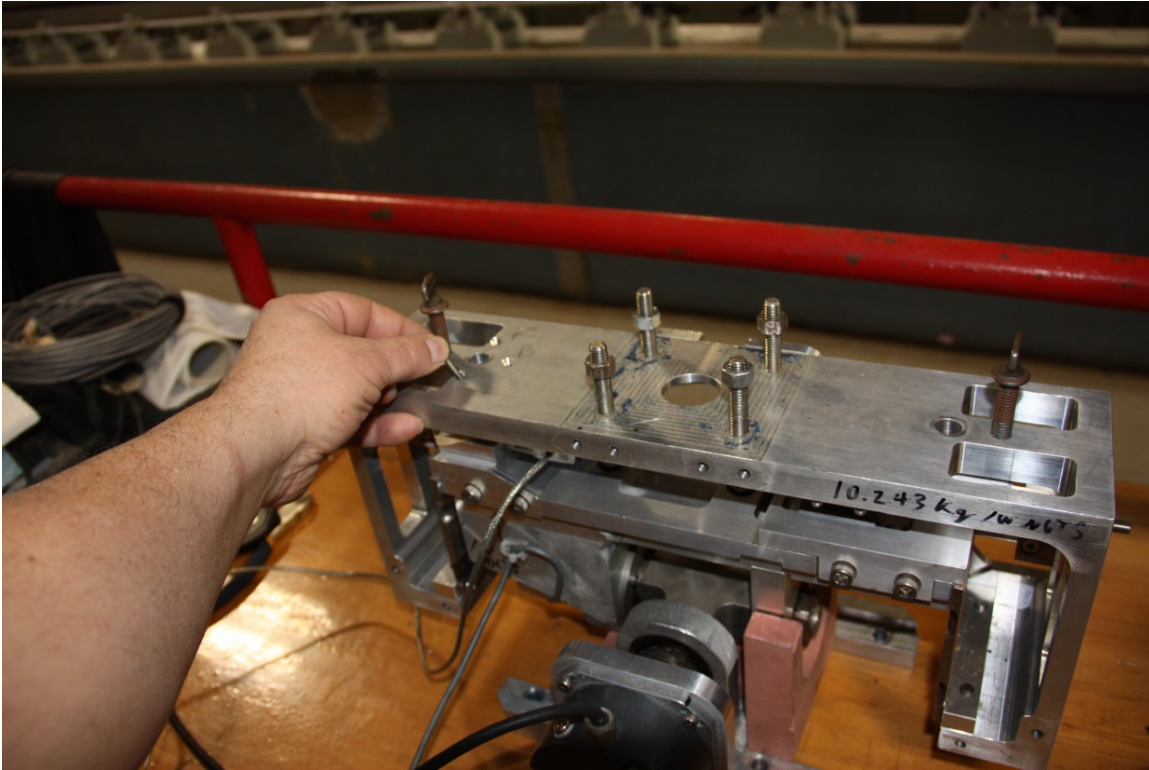

Tighten screws in flex link bracket.

Loosen screws in block adjuster install to fit install adjust and tighten screws. Remove spacer block Dyno is ready for use and spacer block is reset.

B.1.1.3 Load Cell with Different Form Factor

For any other load cell type being used in this device a flex link of required size to span from the load cell to the flexlink bracket while allowing for final adjustment of the bracket will have to be produced .

B) Loosen four bolts on flex link attachment

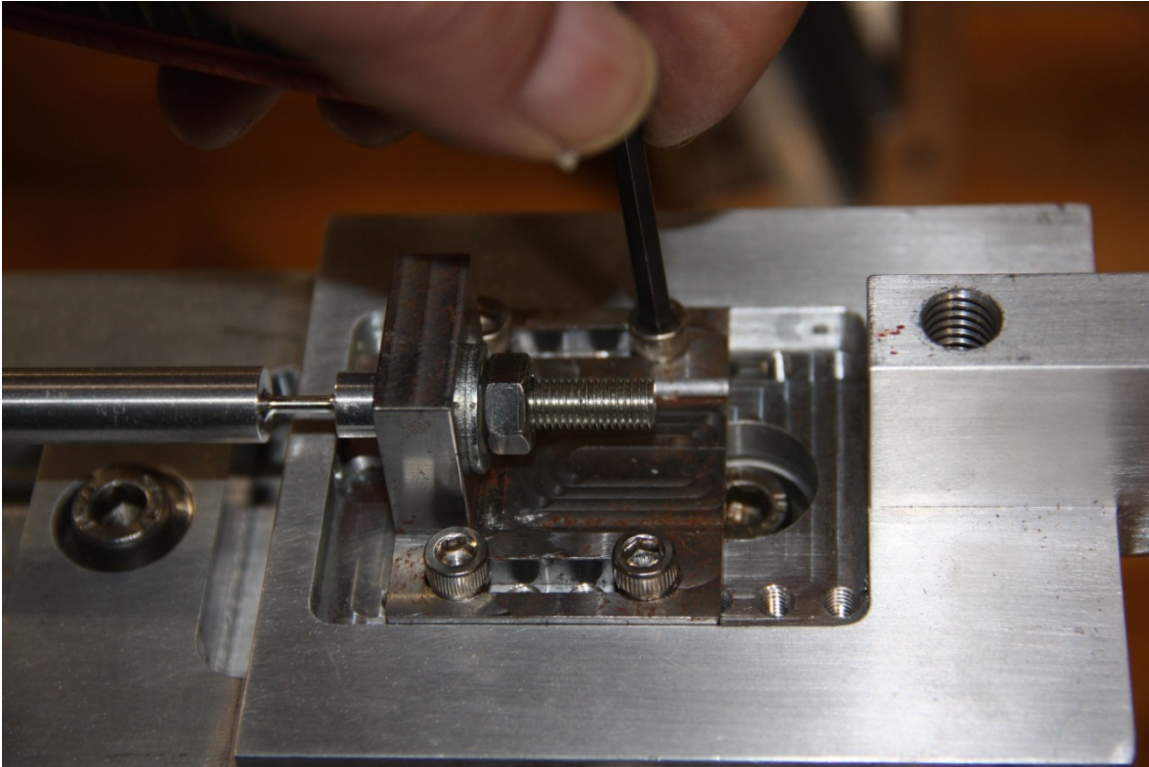

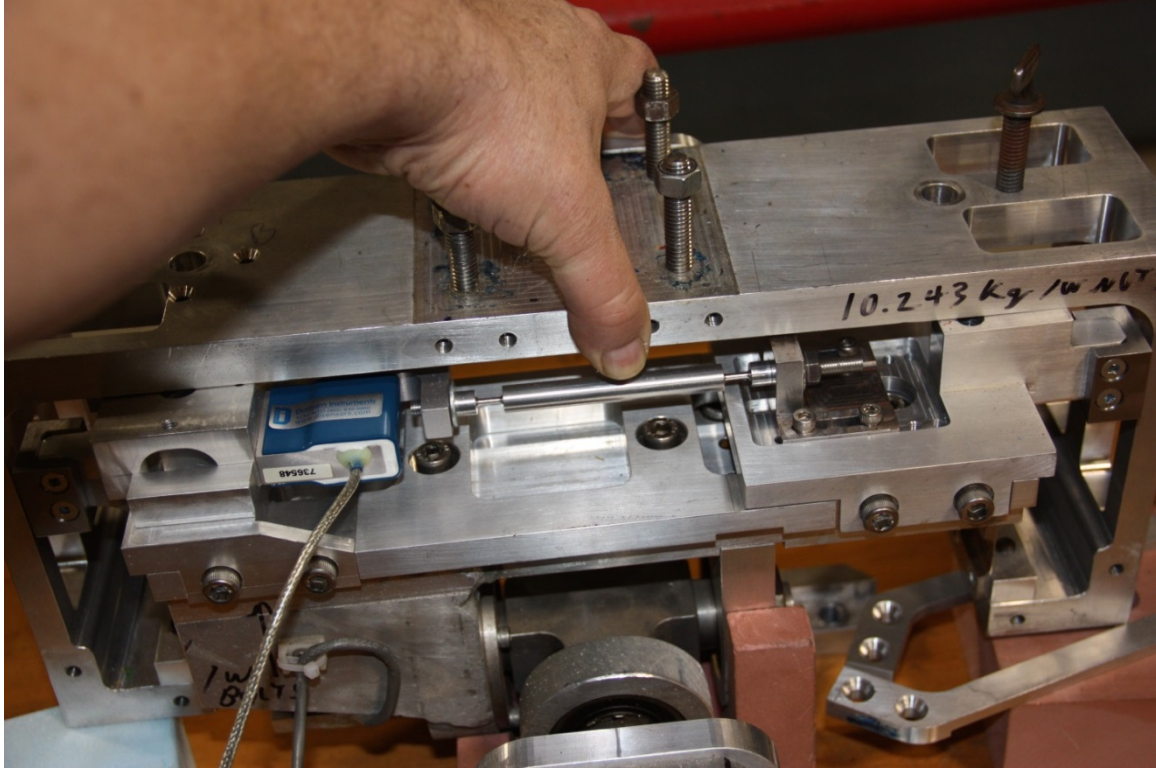

- 3) Install all the screws fastening the flexplates to the dyno live side loosely.

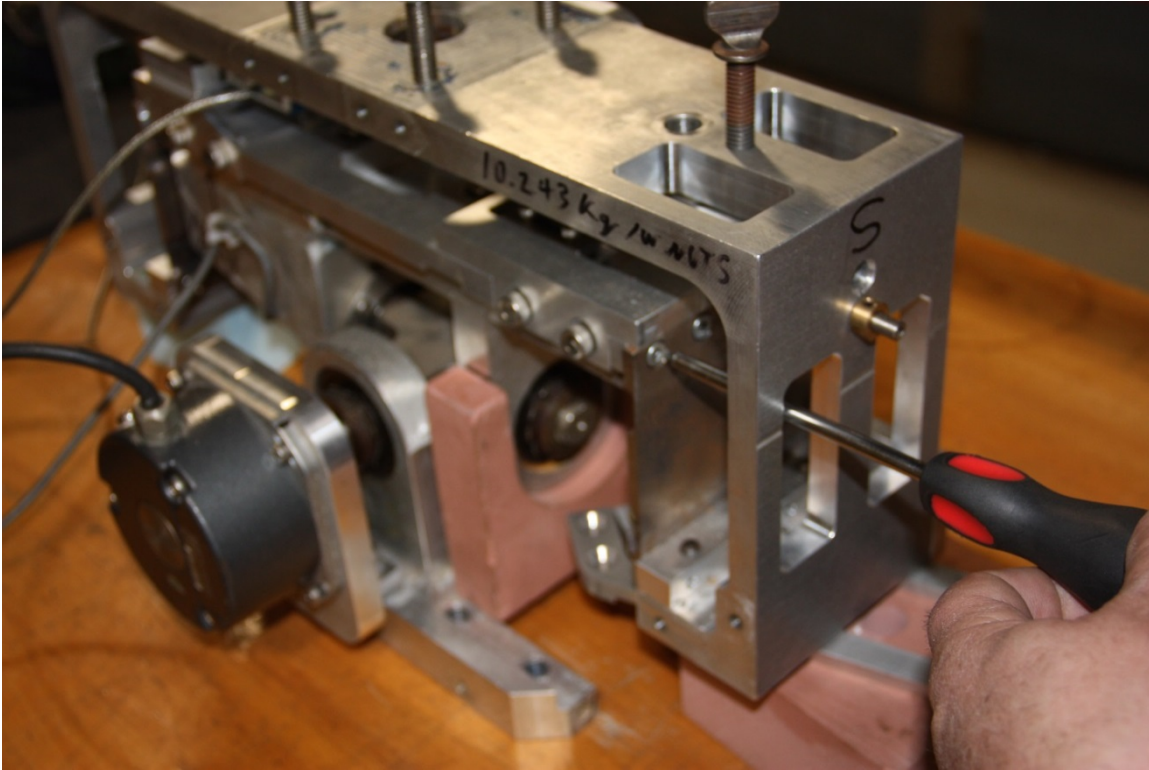

Gently tighten the screws.

- 4) Adjust loadcell block and install the screws to fasten the load cell mount to the dead side of the dyno.

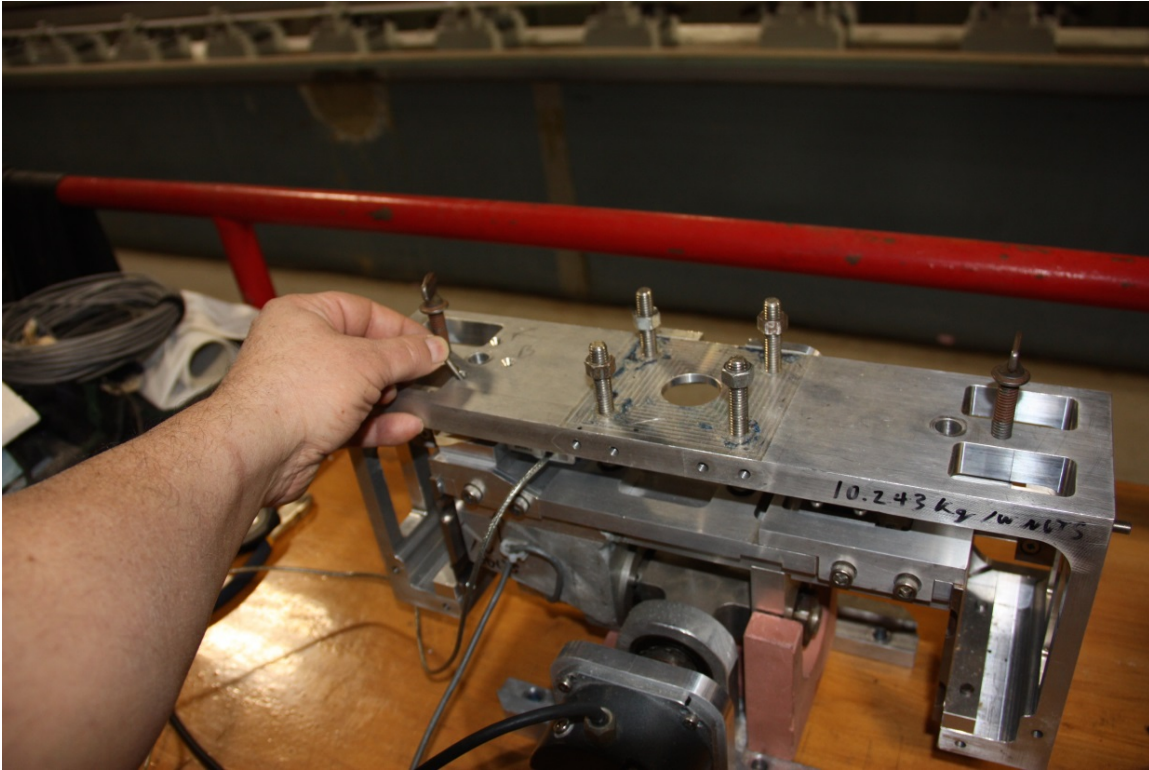

Tighten screws in flex link bracket.

C Procedure 3- Configuration Change

Should the need arise for a change of configuration or repair, use the reverse of **procedure 1** or **2** dependent on current setup to tear down the gimbal to the required point of change and then proceed with the re-assembly procedure required.

Acknowledgements

Project manager	Darrell Sparkes
Project Planning Consultation	Andy Wallace, Ian Robbins
Design concept	Darrell Sparkes
Design consultation	Rob Pallard, Scott Reid, Mathew Garvin
Final Design	Darrell Sparkes
Mechanical drawings, CAD Models	Darrell Sparkes
Data Analysis	Rob Pallard
Structural analysis	Mathew Garvin
Lab Report	Darrell Sparkes
Lab Report Contributions	Rob Pallard
Manufacture	DFS (Scott Reid, Nick Cantwell, Blair Parsons, Enos Harnum)

Standard Uncertainty of Calibration (SEE) Analysis of SM-25 Load cell

Resistance 25		SJS-TOWDA	Channel	13			Chauvenet	2.10017
Data Point	Physical Value (N)	Measured Value [volts]	Fitted Curve Value (N)	Error (N)				
1	28.108	0.0071033	28.10804	4.29E-05				0.00787
2	36.637	0.0095467	36.64332	0.006321				1.160348
3	47.714	0.0127159	47.71397	-2.6E-05				0.004857
4	62.977	0.0170867	62.98173	0.004729				0.868148
5	78.254	0.0214606	78.26046	0.006458		C0	3.295287 N	1.185589
6	97.7	0.027024	97.6943	-0.0057		C1	3493.15 N/volt	1.046216
7	117.38	0.0326588	117.3772	-0.00276				0.506898
8	-8.57	-0.003397	-8.57009	-9.3E-05				0.017018
9	-17.099	-0.005838	-17.099	2.58E-05				0.004741
10	-28.108	-0.008993	-28.118	-0.01	<== Max Error			1.835675
11	-47.714	-0.014602	-47.7112	0.002799				0.513783
12	-62.977	-0.018974	-62.9845	-0.00746				1.37037
13	-78.254	-0.023346	-78.2567	-0.00273				0.501832
14	-117.368	-0.03454	-117.36	0.008402				1.542386
			SEE	0.005447 N				
			Max Error	0.01 N				
			Cal Range	-117.368	117.38 N			

Standard Uncertainty of Calibration (SEE) Analysis of SM-10 Load cell

Tow Force		SJS-TOWDA	Channel	17			Chauvenet	2.31099
Data Point	Physical Value (N)	Measured Value [volts]	Fitted Curve Value (N)	Error (N)				
1	-47.0784	-0.032675	-47.0724	0.006035				1.599363
2	-43.155	-0.029919	-43.1513	0.003688				0.977177
3	-39.232	-0.027162	-39.2293	0.002695				0.714092
4	-35.3088	-0.024406	-35.309	-0.00023				0.062177
5	-31.3856	-0.021645	-31.381	0.00459		C0	-0.59129 N	1.216283
6	-27.4624	-0.018888	-27.4602	0.00222		C1	1422.5 N/volt	0.588423
7	-23.5392	-0.016133	-23.5405	-0.00129				0.34316
8	-19.616	-0.013377	-19.6201	-0.00405				1.073411
9	-15.6928	-0.01062	-15.6985	-0.00571				1.513745
10	-11.7696	-0.007862	-11.7751	-0.00549				1.453627
11	-7.8464	-0.005104	-7.8513	-0.0049				1.298021
12	-3.9232	-0.002346	-3.9284	-0.0052				1.37826
13	3.9232	0.0031712	3.919799	-0.0034				0.90138
14	7.8464	0.0059308	7.845396	-0.001				0.266029
15	11.7696	0.0086886	11.76835	-0.00125				0.330162
16	15.6928	0.0114466	15.69163	-0.00117				0.31031
17	19.616	0.0142067	19.61788	0.001882				0.498761
18	23.5392	0.0169643	23.54055	0.001354				0.358698
19	27.4624	0.0197235	27.4656	0.0032				0.847939
20	31.3856	0.0224838	31.39217	0.00657	<== Max Error			1.740993
21	35.3088	0.0252345	35.30503	-0.00377				0.99912
22	39.232	0.0279942	39.23081	-0.00119				0.31545
23	43.1552	0.0307546	43.15747	0.002271				0.601764
24	47.0784	0.0335139	47.08256	0.004156				1.10136
			SEE	0.003774 N				
			Max Error	0.00657 N				
			Cal Range	-47.0784	47.0784 N			

Standard Uncertainty of Calibration (SEE) Analysis of K&R R35-I Load cell

Resistance		Cav Tunne	Channel	5			Chauvenet	2.39398
Data Point	Physical Value (N)	Measured Value [volts]	Fitted Curve Value (N)	Error (N)				
1	4.296	0.000261	4.250719	-0.04528				1.233408
2	8.57	0.000464	8.5114	-0.0586				1.596208
3	17.099	0.00087	17.04932	-0.04968				1.353179
4	28.108	0.001393	28.05711	-0.05089				1.386057
5	36.637	0.001799	36.59482	-0.04218		C0	-1.24439461 N	1.148856
6	39.144	0.001918	39.0997	-0.0443		C1	21031.67687 N/volt	1.206753
7	47.714	0.002326	47.67335	-0.04065				1.107245
8	56.243	0.002732	56.2148	-0.0282				0.768055
9	62.977	0.003053	62.9596	-0.0174				0.473837
10	71.485	0.00346	71.51899	0.033987				0.925757
11	78.254	0.003779	78.22979	-0.02421				0.659455
12	86.824	0.004187	86.81842	-0.00558				0.151988
13	97.792	0.004709	97.78975	-0.00225				0.06116
14	136.906	0.006571	136.9489	0.042924				1.169206
15	176.079	0.008436	176.1885	0.109542	<== Max Error			2.983802
16	-8.57	-0.000346	-8.52108	0.048925				1.332663
17	-17.099	-0.000752	-17.0685	0.030546				0.832037
18	-28.108	-0.001276	-28.0835	0.024478				0.666763
19	-36.637	-0.001682	-36.6229	0.014059				0.382939
20	-39.144	-0.001801	-39.1175	0.026475				0.721161
21	-47.714	-0.002209	-47.7008	0.013151				0.358229
22	-56.243	-0.002615	-56.2352	0.007824				0.213111
23	-62.977	-0.002936	-62.9878	-0.01079				0.29383
24	-71.485	-0.00334	-71.4931	-0.00812				0.221272
25	-78.254	-0.003661	-78.2422	0.011817				0.321895
26	-86.824	-0.004069	-86.8191	0.004891				0.133219
27	-97.792	-0.00459	-97.7848	0.007205				0.19625
28	-136.906	-0.00645	-136.895	0.011396				0.310402
29	-176.079	-0.008312	-176.056	0.022766				0.620111
30	-195.656	-0.009243	-195.638	0.018127				0.493758
			SEE	0.036712	N			
			Max Error	0.109542	N			
			Cal Range	-195.656	176.079	N		

Standard Uncertainty of Calibration (SEE) Analysis of K&R R35-I Load cell after removal of outlier determined using Chauvenet's Criterion for rejection.

Resistance		Cav Tunne	Channel	5			Chauvenet	2.38152
Data Point	Physical Value (N)	Measured Value [volts]	Fitted Curve Value (N)	Error (N)				
1	4.296	0.000261	4.256382	-0.03962				1.342972
2	8.57	0.000464	8.517538	-0.05246				1.778373
3	17.099	0.00087	17.05641	-0.04259				1.443674
4	28.108	0.001393	28.06543	-0.04257				1.443004
5	36.637	0.001799	36.60409	-0.03291		C0	-1.23934352 N	1.115559
6	39.144	0.001918	39.10924	-0.03476		C1	21034.02075 N/volt	1.178146
7	47.714	0.002326	47.68385	-0.03015				1.021922
8	56.243	0.002732	56.22626	-0.01674				0.567537
9	62.977	0.003053	62.97181	-0.00519				0.175907
10	71.485	0.00346	71.53215	0.047147				1.598199
11	78.254	0.003779	78.2437	-0.0103				0.349218
12	86.824	0.004187	86.83329	0.009285				0.314762
13	97.792	0.004709	97.80584	0.013843				0.469244
14	136.906	0.006571	136.9694	0.063376	<== Max Error			2.14835
								4.554823
16	-8.57	-0.000346	-8.51683	0.053165				1.80221
17	-17.099	-0.000752	-17.0652	0.033833				1.146899
18	-28.108	-0.001276	-28.0815	0.026538				0.899605
19	-36.637	-0.001682	-36.6218	0.015167				0.514131
20	-39.144	-0.001801	-39.1167	0.027306				0.925619
21	-47.714	-0.002209	-47.701	0.013025				0.441529
22	-56.243	-0.002615	-56.2363	0.006746				0.228691
23	-62.977	-0.002936	-62.9896	-0.01262				0.427697
24	-71.485	-0.00334	-71.4959	-0.0109				0.369532
25	-78.254	-0.003661	-78.2457	0.008288				0.280933
26	-86.824	-0.004069	-86.8236	0.000405				0.013727
27	-97.792	-0.00459	-97.7905	0.001497				0.050742
28	-136.906	-0.00645	-136.905	0.001329				0.045053
29	-176.079	-0.008312	-176.071	0.008335				0.282534
30	-195.656	-0.009243	-195.654	0.001514				0.051314
			SEE	0.0295 N				
			Max Error	0.063376 N				
			Cal Range	-195.656	136.906 N			

Appendix B – Stop Blocks for Gimbal Storage, Transport and Maintenance

Once the dyno is installed in the model remove the stop blocks before the tow post is attached. (If space in the model will not allow for removal of the stop blocks after installation remove stop blocks first.)

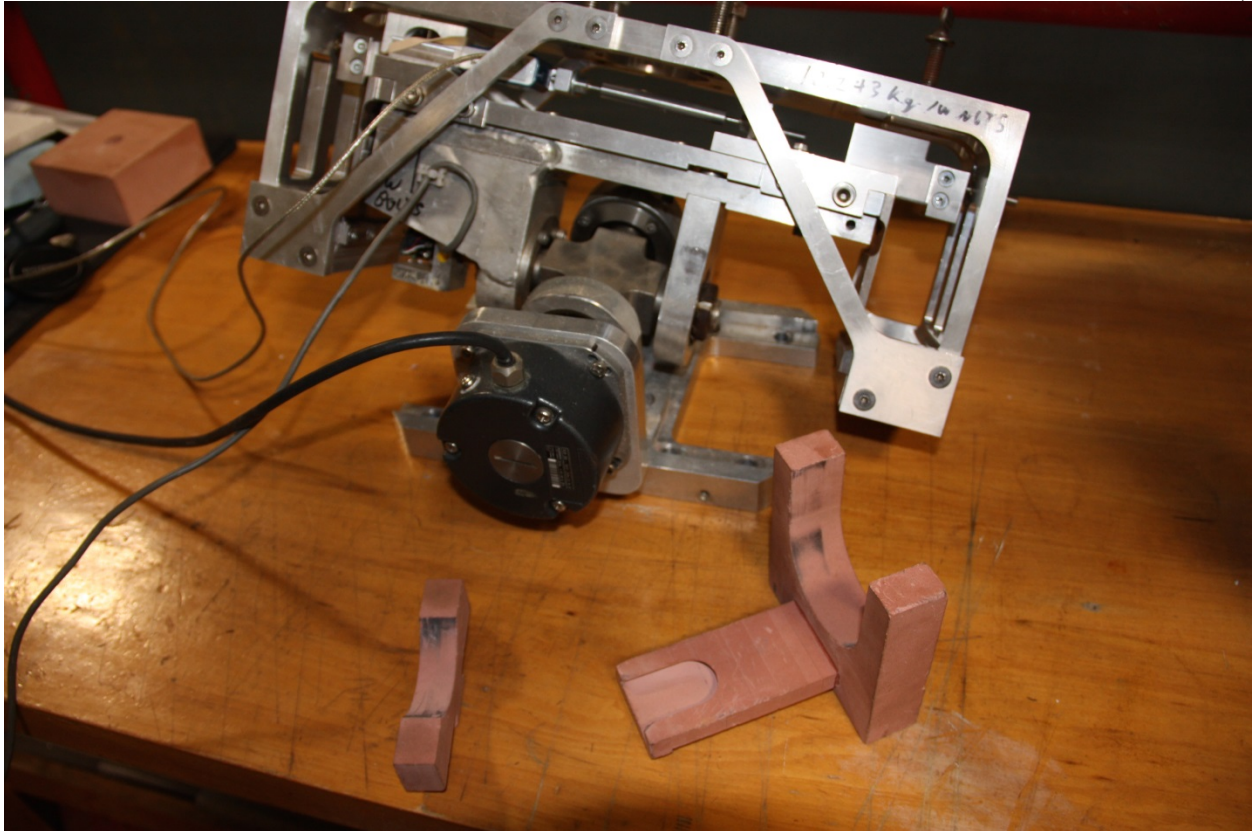

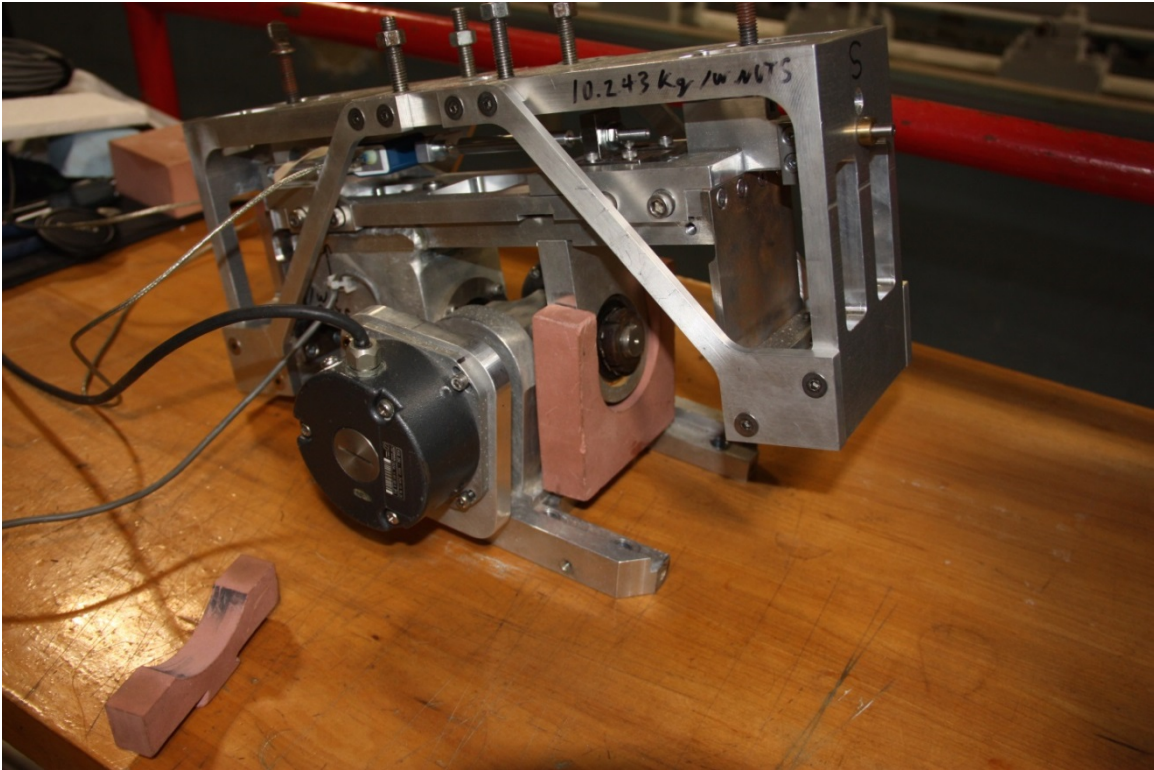
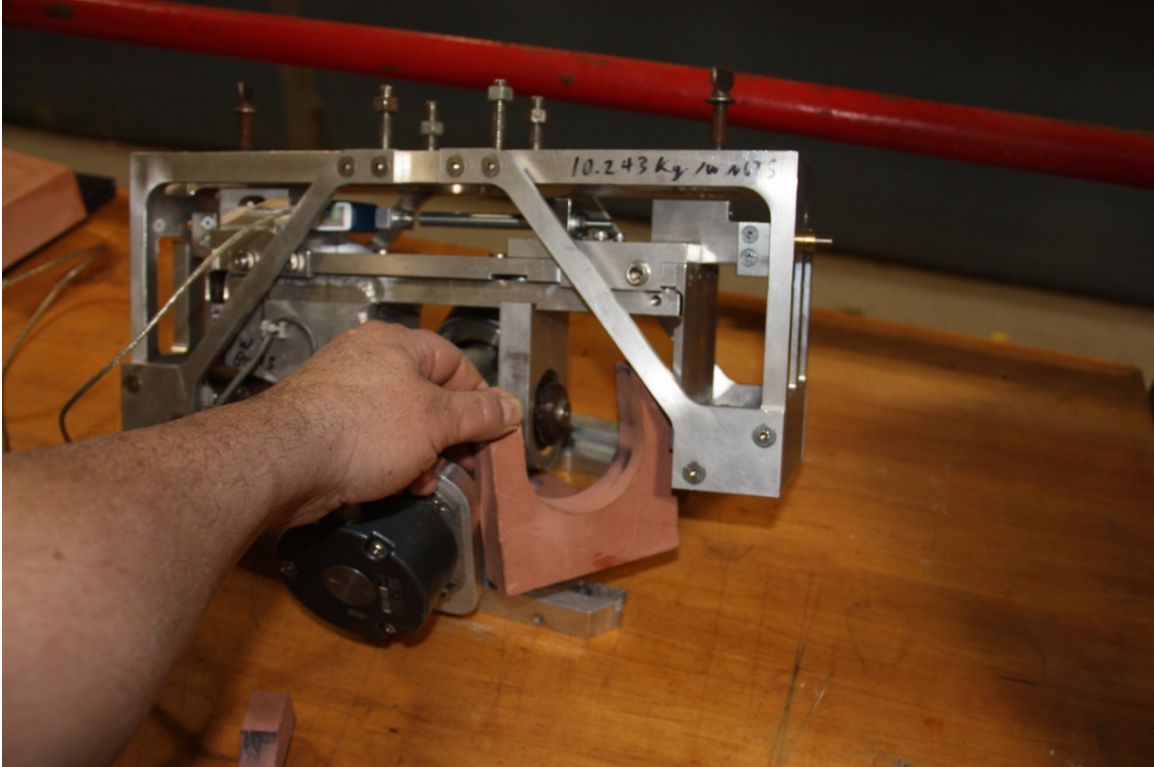

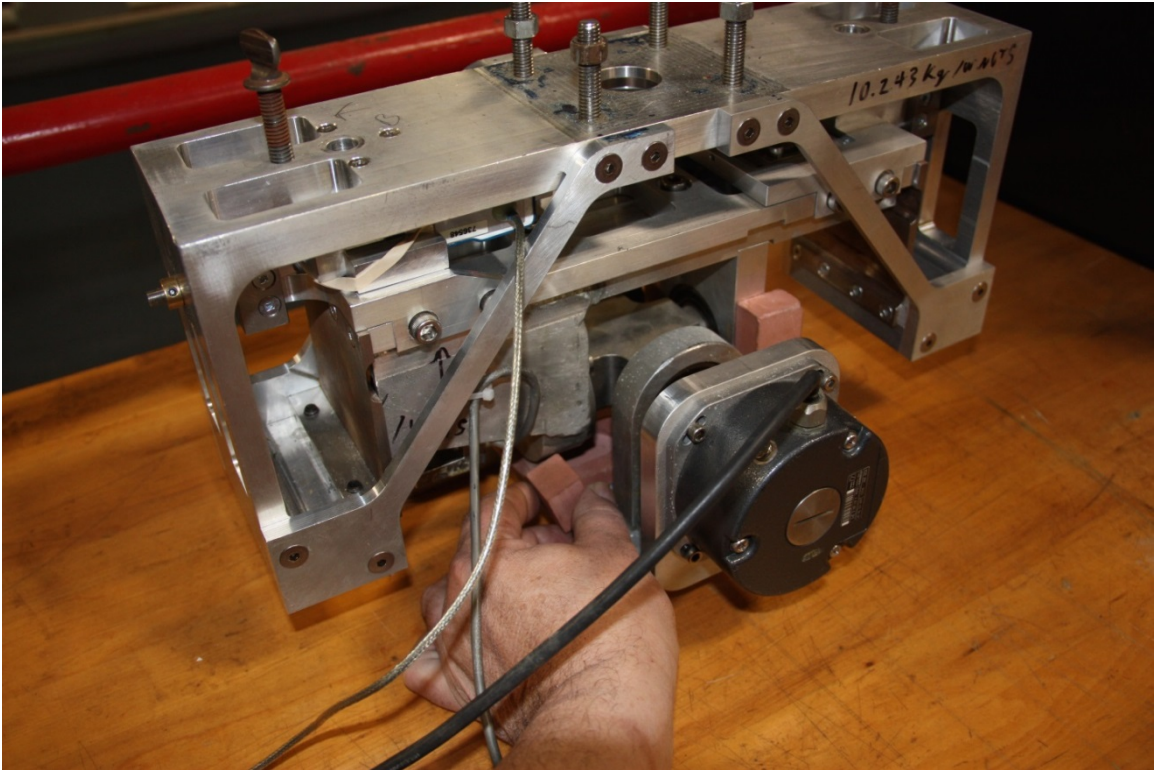
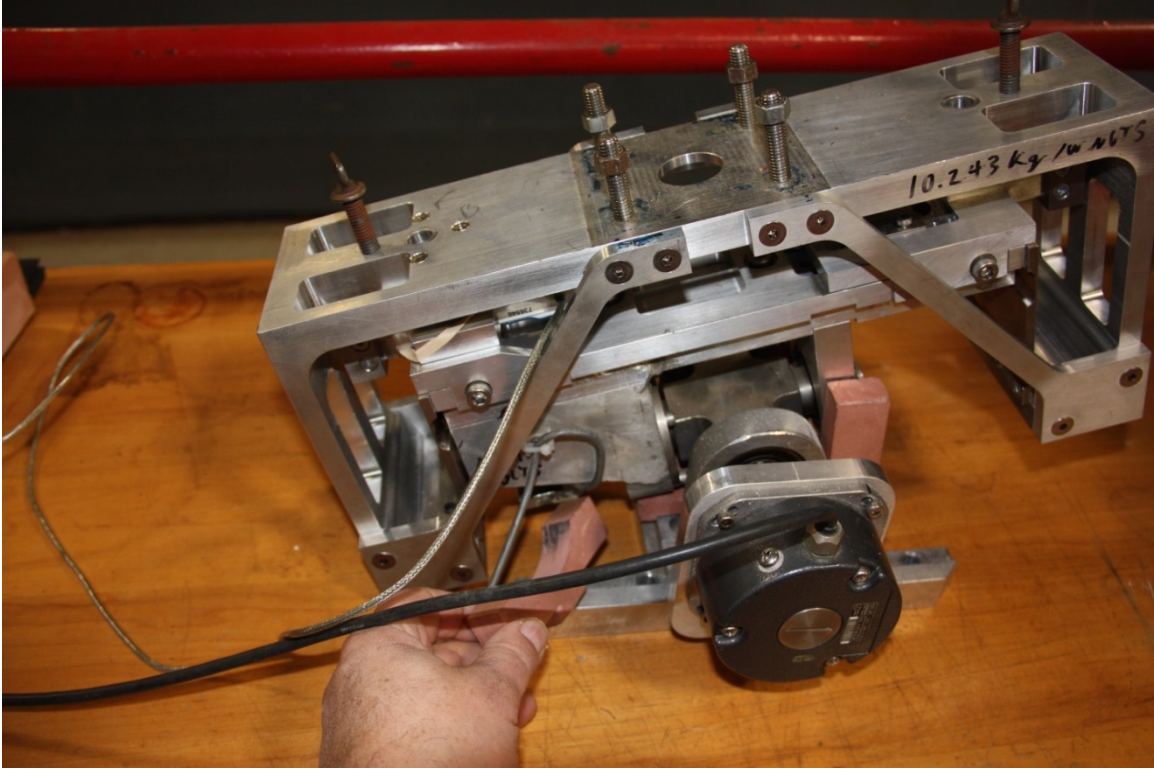

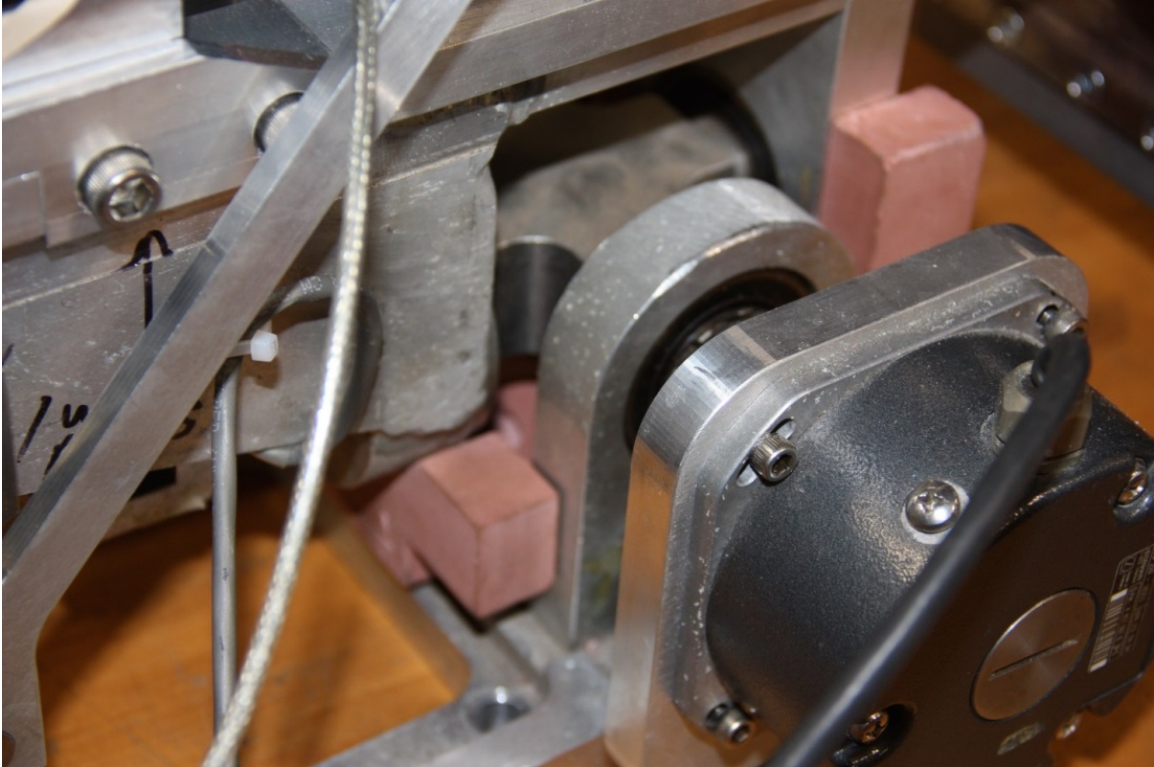

Appendix C – Load cell positioning blocks

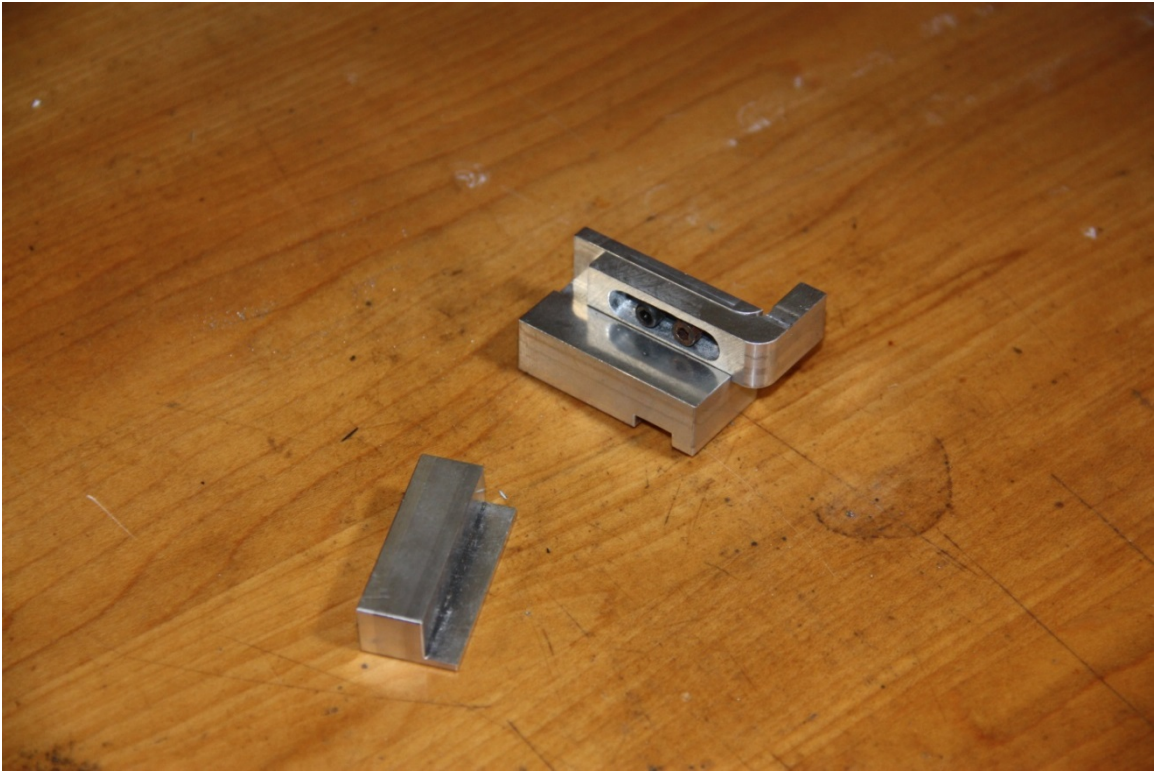

Appendix D – Limit Stops

Limit stops should be set during physical calibration or test loading (for the K&R unit) at the maximum limit of the load cell being used. The stops are an 80 TPI adjuster that are locked with a small hex grub screw. Ensure the grub screw is loosened before adjusting threaded stop.

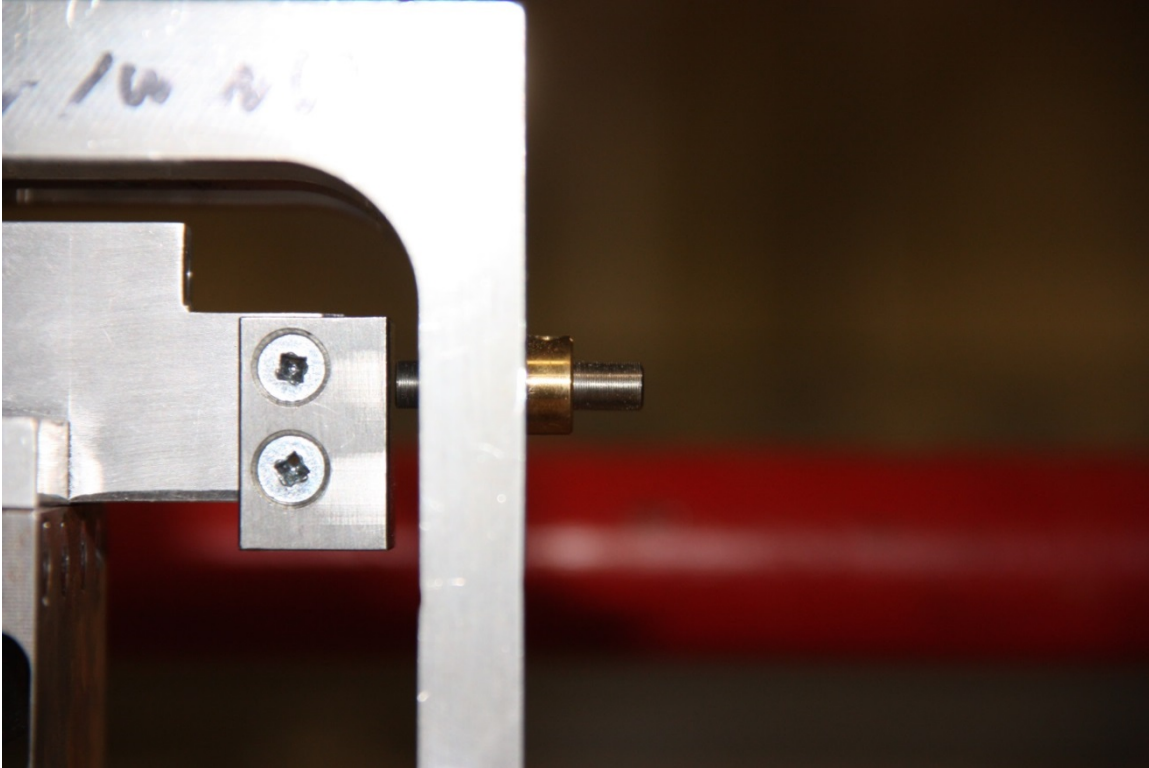

Appendix E –Mounting to Cussons Moment Arm Calibrator

Calibration and setting of the limit stops of the scalable resistance dynamometer should be performed with the unit inverted on the moment arm Cussons K&R moment balance as below. Attach the moment arm flex link to the temporary extension ling of the scalable resistance unit.

