



## NRC Publications Archive Archives des publications du CNRC

### Real-Time Tracking of Objects for Space Applications Using a Laser Range Scanner

Blais, François; Couvillon, R.A.; Rioux, Marc; MacLean, S.G.

This publication could be one of several versions: author's original, accepted manuscript or the publisher's version. /  
La version de cette publication peut être l'une des suivantes : la version prépublication de l'auteur, la version acceptée du manuscrit ou la version de l'éditeur.

#### **NRC Publications Record / Notice d'Archives des publications de CNRC:**

<https://nrc-publications.canada.ca/eng/view/object/?id=5d14b4ca-c65e-4cc4-b365-3fdd278afc18>

<https://publications-cnrc.canada.ca/fra/voir/objet/?id=5d14b4ca-c65e-4cc4-b365-3fdd278afc18>

Access and use of this website and the material on it are subject to the Terms and Conditions set forth at

<https://nrc-publications.canada.ca/eng/copyright>

READ THESE TERMS AND CONDITIONS CAREFULLY BEFORE USING THIS WEBSITE.

L'accès à ce site Web et l'utilisation de son contenu sont assujettis aux conditions présentées dans le site

<https://publications-cnrc.canada.ca/fra/droits>

LISEZ CES CONDITIONS ATTENTIVEMENT AVANT D'UTILISER CE SITE WEB.

**Questions?** Contact the NRC Publications Archive team at

PublicationsArchive-ArchivesPublications@nrc-cnrc.gc.ca. If you wish to email the authors directly, please see the first page of the publication for their contact information.

**Vous avez des questions?** Nous pouvons vous aider. Pour communiquer directement avec un auteur, consultez la première page de la revue dans laquelle son article a été publié afin de trouver ses coordonnées. Si vous n'arrivez pas à les repérer, communiquez avec nous à PublicationsArchive-ArchivesPublications@nrc-cnrc.gc.ca.





National Research  
Council Canada

Conseil national  
de recherches Canada

Institute for  
Information Technology

Institut de technologie  
de l'information

# **NRC - CNRC**

---

## ***Real-Time Tracking of Objects for Space Applications Using a Laser Range Scanner \****

Blais, F., Couvillon, R.A., Rioux, M., and MacLean, S.G.  
March 1994

\* published in the Proceedings of the AAAI Conference on Intelligent Robots in Field, Factory, Service and Space. Houston, Texas, USA. March 20-24, 1994. Vol. II, pp. 464-472. NRC-37109.

Copyright 1994 by  
National Research Council of Canada

Permission is granted to quote short excerpts and to reproduce figures and tables from this report, provided that the source of such material is fully acknowledged.

# REAL-TIME TRACKING OF OBJECTS FOR SPACE APPLICATIONS USING A LASER RANGE SCANNER<sup>1</sup>

F. Blais, R.A. Couvillon, M. Rioux  
Institute for Information Technology  
National Research Council of Canada  
Ottawa, Ontario, Canada K1A 0R6

S.G. MacLean  
Canadian Astronaut Program  
Canadian Space Agency  
St-Hubert, Québec, Canada J3Y 8Y9

## Abstract

Real-time tracking of multiple targets or geometrical features of an object using a variable resolution laser scanner is presented. The scanner is characterized by its robustness to ambient illumination, even the sun shining directly into the sensor, and its tracking resolution. The sensor to extract registered range and intensity information for each scanned point on the object at a rate of 18 kHz uses two high-speed galvanometers and a collimated laser beam. Three-dimensional real-time tracking using Lissajous patterns proves to be very attractive for space applications. Integration with the existing photogrammetry-based Advanced Space Vision System (ASVS) is discussed.

## Introduction

It is now well accepted that vision will play a major role in both supervised and unsupervised operations for the automation of several space-related activities. Specifications state that the Artificial Vision Unit will support rendez-vous and proximity operations including payload tracking, capture, and berthing in both teleoperation and adaptive control modes.<sup>1,2</sup> It is also recognized that vision will play a major role during the assembly and maintenance operations of the space station.

The current Artificial Vision Function (AVF) is based on the Space Vision System (SVS) that was demonstrated on CANEX-2. The SVS analyzes video signals from the closed circuit television system of the

space shuttle and provides real-time position and orientation information about an object with a cooperative target array.<sup>2</sup> The baseline requirements for the Artificial Vision Function are as follows:

- To identify a suitably illuminated object (target) from its video image.
- To estimate the position, attitude, translation, and rotational rate of the object.
- To provide appropriate camera control to track the object.
- To be able to track objects before capture by manipulators and berth objects/payloads handled by manipulators.

To achieve robust adaptive control, supervision, and inspection, the vision system must be 100% operational throughout the changing illumination conditions in orbit. Unfortunately, the quality of the images produced by standard video-camera-based systems is adversely affected by the presence of the sun or any other strong source of light. Poor contrast between features on the object and background, and saturation of the photo-detector array often make it difficult to analyze the video images. Video camera reliability during normal operation is questionable and can compromise the success of the operation or at least seriously limit its practical use.

Although camera-based systems are very attractive because of their ease of use and simplicity of integration with existing equipment, it is highly desirable to offer a complementary vision system that will not be restricted by operational conditions such as sun interference. The proposed laser scanner approach offers the advantage of being almost 100% operational throughout the changing illumination conditions in

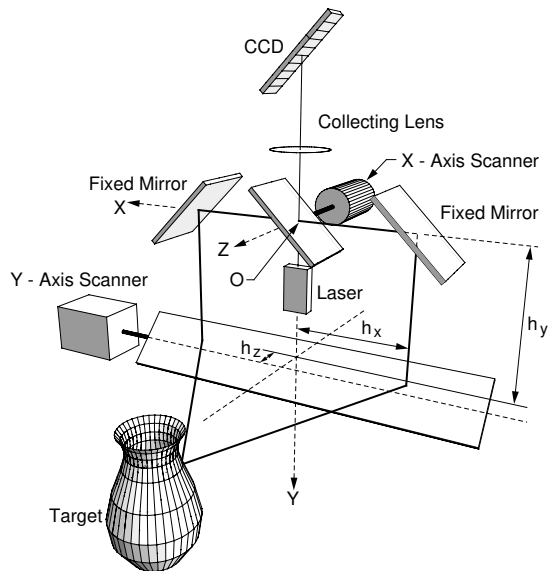
---

<sup>1</sup> Copyright © 1994 by National Research Council Canada. Published by the American Institute of Aeronautics and Astronautics, Inc. with permission. NRC 37109

orbit. The technique, developed at NRC in collaboration with the CSA, is designed to be insensitive to background illumination such as the earth albedo and the sun radiation and most of its reflections.<sup>3,4</sup> Immunity to background interference is the result of the very narrow band of frequencies emitted by the laser light that can be tuned by optical filters, by special optical design to extract range information, and by proprietary real-time signal processing techniques used to distinguish between the laser beam and any remaining sources of interference (e.g., specular reflections).

### The Laser Scanner

Figure 1 shows the geometry of this prototype based on the auto-synchronized time-flying single-point technique.<sup>5</sup> The system is comprised of two orthogonally mounted scanning mirrors: the X-axis scanning mirror, used for range triangulation, and the Y-axis mirror. The two mirrors are driven by accurate galvanometers. The light beam generated by the laser is deflected by a mirror and scanned on the object. A camera, consisting of a lens and a position-sensitive photodetector, measures the location of the image illuminated point on the object. By simple trigonometry, the three-dimensional coordinates of that point are calculated.<sup>6,7</sup>

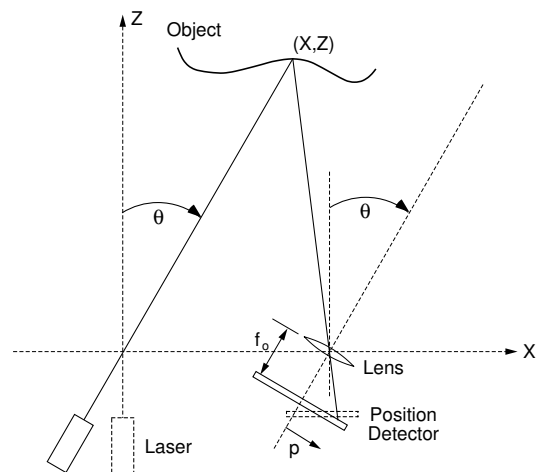


**Figure 1:** Schematic representation of the dual-axis auto-synchronized range scanner (reprinted from Reference 7).

Some of the advantages of the auto-synchronized technique are a large field of view, high accuracy, and immunity to ambient illumination.<sup>8</sup> A conventional camera must continuously monitor the whole field of view, making it very susceptible to sun interference. The laser scanner technique has a small instantaneous field of view limiting the undesired interference. Such a system is optically light efficient because the received laser power is focused onto a small spot thereby increasing the signal-to-noise ratio of the returned signal. Automatic control of the laser power source further extends the dynamic range of the scanner.

Figure 2 illustrates the equivalent optical geometry. The basic concept is that the projection of the light spot is synchronized with its detection. The instantaneous field of view of the position sensor follows the spot as it scans the scene. An external optical perturbation can interfere with the detection only when it intercepts the instantaneous field of view of the scanner. At this level, electronic signal processing is used to filter these false readings to obtain the correct 3-D measurement. The total field of view of the laser camera is related only to the scanning angles of the galvanometers and mirrors as opposed to a conventional camera where field of view and image resolution are intimately linked, the larger field of view the smaller pixel resolution achievable.

Although laser scanners are usually slower than their

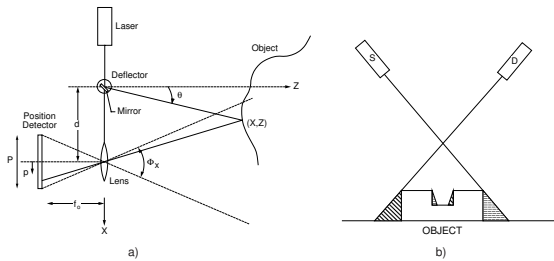


**Figure 2:** Basic principle of synchronized scanner, second axis not shown (reprinted from Reference 8).

TV camera counterparts when used in a conventional imaging or raster scan mode of operation, the same laser scanner can obtain refresh rates of more than 130 Hz with a pointing resolution of 15000 elements  $\times$  15000 elements in the tracking mode (single target). Consequently, the resolution and speed of the laser scanner exceed conventional video cameras. The high pointing accuracy of a laser beam and the large depth of field of the scanner enable the acquisition of large 3-D images of 4000 pixels  $\times$  4000 pixels or more. To achieve similar resolution, a video camera would need a high-quality optical lens and specially designed high-resolution CCD cameras.

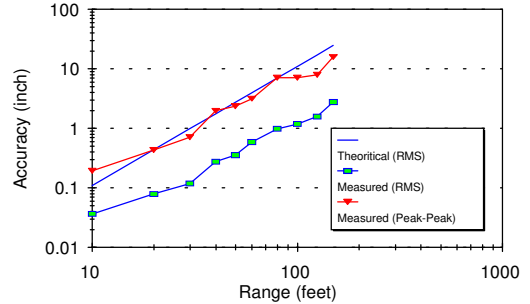
A custom-designed galvanometer controller board gives access to any pixel in the field of view of the range sensor and provides the random access tracking capability.<sup>3,4</sup> The controller permits interrogation of any point in the scene without having to sample the entire field of view of the scanner. This Region Of Interest (ROI) sampling technique offers great potential for rapid and efficient acquisition of dense and accurate 3-D images over a large volume of measurement.

Figure 3 is a photograph of the laboratory prototype of the auto-synchronized laser scanner developed for this application. Tables I and II and Figures 4 and 5 summarize the characteristics of this laser scanner

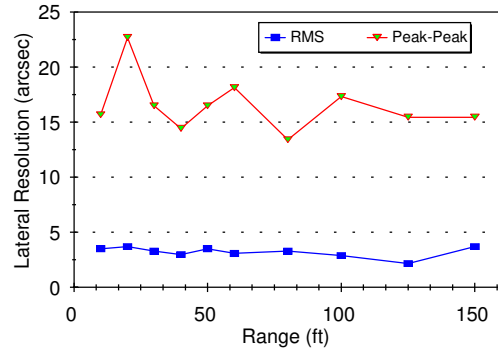


**Figure 3:** Photograph of the laser scanner prototype.

prototype in the triangulation mode of operation.



**Figure 4:** Range resolution (single point).



**Figure 5:** Angular pointing resolution (tracking mode using Lissajous figures).

### Real-time Tracking

Real-time tracking of targets or geometrical features on an object is implemented using Lissajous figures, to obtain good scanning speed and accuracy.<sup>3</sup> A Lissajous figure is mathematically defined by

$$\vartheta(t) = A_{\vartheta} \cos(m\omega t + \delta_{\vartheta}) + \theta_c \quad (1)$$

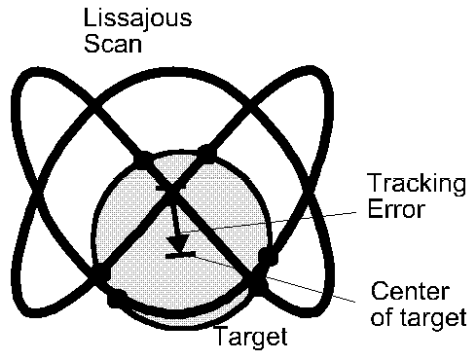
$$\phi(t) = A_{\phi} \cos(n\omega t + \delta_{\phi}) + \phi_c \quad (2)$$

where  $A_{\vartheta}$  and  $A_{\phi}$  are the amplitudes of the Lissajous

**Table I:** Physical characteristics.

Dimensions	10.5 in × 6.25 in × 4 in
Data Type	3-D and Intensity
Field of view	30° × 30°
Working range	0.6 ft to TBD (>150 ft)
Range accuracy	See Figure 4
Acquisition Speed	18 kHz
Scanning System	Galvanometers

pattern,  $\omega$  the refresh rate of the scan,  $\delta_0$  and  $\phi$  the relative phases of the sinewaves,  $t$  the sampling time, and  $\theta_0$  and  $\phi$  the position of the center Lissajous pattern. The pattern shape is defined using parameters  $m:n$ . For example the pattern illustrated in Figures 6 and 7 is a 3:2 Lissajous figure.

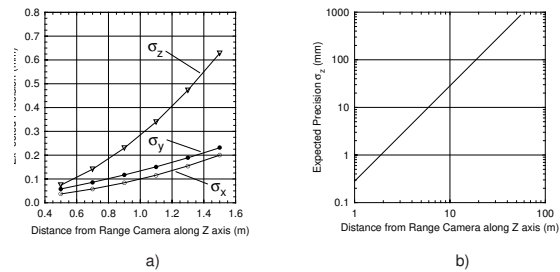


**Figure 6:** Tracking of a circular target using a 3:2 Lissajous pattern.

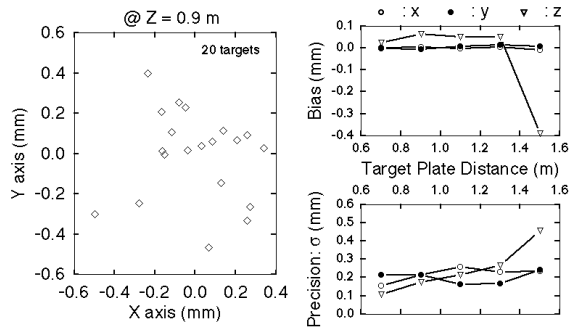
Lissajous patterns are used to scan objects at refresh rates exceeding the frequency response of the mechanical deflection system. The scanning device is not required to stop the acquisition after each trace line as opposed to the raster-type scan illustrated in Figure 8. Instead, the full pattern is used to acquire both range and intensity information. Furthermore, the natural inertia of the galvanometer-mirror structure smooths the scanning pattern and hence increases the pointing accuracy of the tracking

system. As well, Lissajous pattern signals are optimally filtered using the Fourier transform (or notch filter), thus reducing electrical noise, quantization effects, and distortions.<sup>9</sup>

Tracking is implemented using the 3-D range information on the Lissajous pattern, the returned intensity signal from the object, or a combination of both. For example, the location and orientation of the geometrical target is obtained with either the 3-D or



**Figure 7:** Real-time tracking of geometrical targets (e.g., corner or targets) using Lissajous patterns and the laser range sensor.



**Figure 8:** Conventional raster-type acquisition of the 3-D shape of the object.

intensity edges of the object or the intersection of the measured surfaces on an object.

**Table II:** Performances characteristics of the laser scanner.

---

<u>Laser Scanner</u>	<u>Video Cameras</u>
<b>General</b>	
<ul style="list-style-type: none"><li>- Excellent immunity to ambient illumination</li><li>- High-resolution images and large depth of view</li><li>- 3-D and registered intensity images</li><li>- New technology not as widely used</li></ul>	<ul style="list-style-type: none"><li>- Highly susceptible to ambient illumination</li><li>- Low hardware cost</li><li>- Use on-board closed-circuit video cameras system</li></ul>
<b>Optics</b>	
<ul style="list-style-type: none"><li>- Optically efficient, excellent signal-to-noise ratio because all the laser energy is concentrated in a single point</li><li>- Simple on-axis optics</li><li>- Large depth of view (max/min range) and small instantaneous field of view</li><li>- Optical magnification produces good range resolution and large images of the sun to simplify the signal processing and reduce saturation</li><li>- Laser light easily filtered using narrow-bandwidth optical interference filters</li><li>- Eye safety requirements for terrestrial applications (eye-safe if laser at 1.5 <math>\mu\text{m}</math> is used)</li></ul>	<ul style="list-style-type: none"><li>- Simple camera configuration</li><li>- Work typically under ambient illumination or projectors</li><li>- Adversely affected by ambient illumination and sun interference</li><li>- Large instantaneous field of view makes the system susceptible to saturation</li><li>- No optical filtering possible because of the use of ambient illumination (if laser projectors are used large-bandwidth optical filters are required)</li><li>- Compromise between optical magnification and field of view (focal length) and sensitivity and depth of view (f-number)</li></ul>
<b>Scanning devices (galvanometers)</b>	
<ul style="list-style-type: none"><li>- Large scanning angles, high pointing resolution</li><li>- Randomly addressable, almost any scanning patterns can be programmed</li><li>- Mechanically moving devices (relatively slow)</li><li>- Temperature sensitive<sup>2</sup></li></ul>	<ul style="list-style-type: none"><li>- No moving parts except if rotation stage is used for camera pointing</li><li>- Mechanically rugged systems</li><li>- Temperature sensitivity is reduced by years of design and mature technology</li></ul>
<b>Electronics</b>	
<ul style="list-style-type: none"><li>- Simplify the processing of the CCD image</li><li>- Further improve the immunity to ambient illumination</li><li>- Modular architecture easily upgradable</li><li>- Random control and real-time implementation requires good knowledge of the dynamics of the sensor and the application<sup>***</sup></li></ul>	<ul style="list-style-type: none"><li>- 2-D image processing required at video rate</li><li>- Special technique still to be developed to reduce the effect of changing illumination on the targets</li><li>- Modular low-cost electronics</li><li>- All solid-state</li></ul>

---

<sup>2</sup> Temperature compensation is implemented using synchronization photo-detectors.<sup>8</sup>

<sup>\*\*\*</sup> This is valid for any accurate measurement system.

Figure 6 illustrates the tracking principle using a Lissajous figure. The target can be a cylinder, a sphere, or simply a colored target. For long-range measurement a retroreflective target (corner cube or 3M retroreflective tape) is used. Assuming that  $I(t)$  and  $Z(t)$  are, respectively, the intensity and range measurements for each point of the Lissajous pattern defined by equations 1 and 2, the tracking error on the target is computed from the centroid measurements weighted by the intensity of the returned laser signal:

$$\begin{aligned} \Delta r(t) &= I(t) - I_{ref} \\ &\text{if } (I(t) > I_{ref}) \text{ and} \\ &(\Delta r_{min} < (r(t) - r_0) < \Delta r_{max}) \\ &= 0 \quad \text{otherwise} \end{aligned} \quad (3)$$

$$\Delta r = \frac{\sum r(t) I_{val}(t)}{\sum I_{val}(t)} - r_0 \quad (4)$$

$$\Delta \theta = \frac{\sum \theta(t) I_{val}(t)}{\sum I_{val}(t)} - \theta_0 \quad (5)$$

$$\Delta \phi = \frac{\sum \phi(t) I_{val}(t)}{\sum I_{val}(t)} - \phi_0 \quad (6)$$

If a target is lost then

$$\begin{aligned} \Delta r = \Delta \theta = \Delta \phi &= 0 \\ \text{if } \left( \sum I_{val}(t) = 0 \right) \end{aligned} \quad (7)$$

$\theta_0, \phi_0, r_0$  is the position of the scan and consequently the expected position of the target. The intensity threshold  $I_{ref}$  and range validation window  $r_{min}$  and  $r_{max}$  are specific for a target type. Any point outside the range/intensity window is considered not valid and disregarded. Range is extremely useful in equation 3 to make the technique very robust to external perturbations (e.g.,  $r=\infty$  for the sun)

Tracking is implemented in the spherical coordinate system  $(r, \theta, \phi)$  of the laser scanner using the digital feedback structure defined, using the z-transform by:

$$\begin{aligned} \mathfrak{S} &= H_{dir} * \Delta \mathfrak{S} + H_{pred} * \mathfrak{S}_{pred} \\ &\quad + H_{adj} * \Delta \mathfrak{S}_{adj} \end{aligned} \quad (8)$$

$$\mathfrak{S} = [r, \theta, \phi]$$

$$H_{dir} = \frac{\alpha_0 + \alpha_1 z^{-1} + \alpha_2 z^{-2}}{1 - \beta_1 z^{-1} - \beta_2 z^{-2}} \quad (9)$$

$$H_{pred} = \frac{\gamma}{1 - (1 - \gamma) z^{-1}} \quad (10)$$

$$H_{adj}(z) = \frac{1}{1 - \zeta z^{-1}}, \quad \zeta < 1 \quad (11)$$

$z^{-1}$  is the z-transform delay of one sample.  $H_{dir}$  is the direct feedback loop internal to the laser scanner,  $H_{pred}$  is the predicted or expected position of the target, and  $H_{adj}$  is an external user control adjustment.  $H_{adj}$  implements a classical deadbeat controller reducing the tracking error to zero such that the Lissajous pattern is always centered on the target. The predicted or expected position  $H_{pred}$  is used to give an estimate of the position of the target. This estimate is obtained either from the known or calculated position of the object or from the ASVS-laser scanner interface.  $H_{adj}$  allows an immediate fine adjustment of the target position. This is especially useful in the search mode when the target is not found (equation 7) and the predicted position is not accurate enough (e.g., during initial search) to lock the laser scanner pattern on the target. External user control is used to move the pattern over the target. Equation 11, a lossy integrator, gradually removes this external correction and is replaced by the correction  $H_{dir}$ .

The laser scanner automatically adjusts the size of the scan according to the distance of the target from the camera:

$$A_\theta = A_\phi = \frac{A_{ref}}{r} \quad (12)$$

For each target, a set of parameters  $A_{ref}, I_{ref}, \Delta r_{min}, \Delta r_{max}$  is defined. Optimum coverage of the surface of the target and pointing resolution are obtained because the Lissajous pattern is always centered and scaled on the target independently of the distance of the target.



## Multiple Tracking of Targets, Photogrammetry, and the Laser Scanner

The photogrammetry mode of operation of the ASVS to be used on board the space shuttle<sup>1</sup> and the laser scanner are compatible and easily interfaced; the deflection angles of the galvanometers directly provide the angular separation between the targets. Then, with photogrammetry techniques, the object position  $X$ - $Y$ - $Z$  and attitude parameters yaw-pitch-rotation are computed by minimizing the quadratic error between the expected position of the targets computed from the model of the object and the measured positions provided by the laser scanner.<sup>2</sup>

Real-time and physical constraints caused by switching quickly between multiple targets and limited by the inertia of moving mechanical devices must be considered, based on the application requirements. A careful investigation of the complete mechanical, optical, and electrical characteristics of the hardware and software is needed to achieve optimum tracking performance.

The laser scanner is programmed to sequentially scan different sections or targets on one or multiple objects, as illustrated in Figures 7 and 9. A list of all possible scanning strategies used for a given task are pre-defined. Each strategy contains a list of the visible targets to scan and is optimized for a given application. The laser scanner uses this list to sequentially scan the targets on the different objects.

A scenario under study for the assembly of the space station is the berthing of the LAB/A Module on the APN (Aft Port Node) CBM interface in the Space Station using the Remote Manipulator System (RMS) as graphically illustrated in Figure 9. The vision system task is to provide the position and orientation of the LAB/A module relative to the APN and ITA (Integrated Trust Assembly, not shown) modules as well as visual guidance during berthing operations.

The visible and nonvisible targets on the two main objects are:

<i>Targets</i>	<i>Module</i>
T <sub>1</sub> to T <sub>8</sub>	LAB/A
T <sub>9</sub> to T <sub>16</sub>	APN (Aft Port Node)

Only the visible targets T<sub>1</sub> to T<sub>4</sub> and T<sub>9</sub> to T<sub>12</sub> are shown in Figure 9.

**Figure 9:** Example of tracking for the assembly of the space station.

The following strategies are defined for this visible section of the objects:

*Strategy = Scanning Target List*

$$\begin{aligned}
 S_0 &= T_1, T_2, T_3, T_4 \\
 S_1 &= T_9, T_{10}, T_{11}, T_{12} \\
 S_2 &= S_0, T_9, S_0, T_{10}, S_0, T_{11}, S_0, T_{12}
 \end{aligned}$$

It is important to acquire fast moving targets as often as possible because of the sequential nature of the scanning method. The basic scanning strategies  $S_0$  and  $S_1$  scan only the targets on their respective objects. They are used to initially locate a relatively fast moving object. When the object is locked by the scanner, the scanning strategy is switched to  $S_2$  to measure the relative position of the LAB/A module with respect to the whole structure. In this example the APN module is considered to be almost stationary and therefore  $S_2$  instructs the laser scanner to scan the moving LAB/A module more often than the other objects. All the targets from the LAB/A module are scanned ( $S_0$ ) followed by one target from the APN module. Although only three strategies are shown, any number can be defined, depending on the application.

The approach used for object tracking allows the operator to fully define the tasks required by the tracking system. Instead of having a single "target or object" detection algorithm controlling the scanner, the user can dynamically tune or replace any element for a given application. New modules are easily built to improve system performances.

The tracking refresh rate for the LAB/A module is

currently limited to 15 Hz for this experiment. Geometrical detection and tracking are computationally expensive and need more processing power to achieve faster tracking speed than the current single 68020 VME processor can provide. Integration of parallel processing using multiple TMS320C40 DSP is planned. Furthermore, several key elements of this system, including geometrical target localization algorithms, absolute real-time calibration (vs. relative calibration), and optimized corrector-predictor tracking techniques, are only at their preliminary stage of study. As the system improves in performance, further modifications can be introduced without redesigning the whole software or hardware environment.

### Laser Scanner and Three-dimensional Imagery

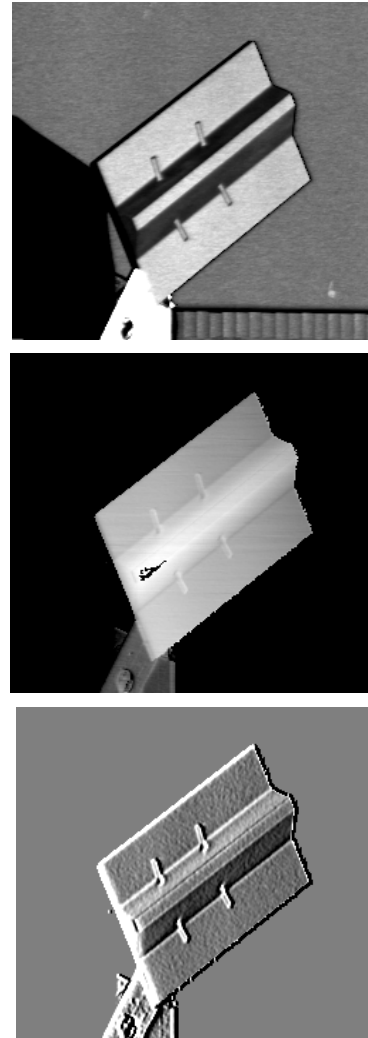
A more conventional imagery method can also be used for tracking, at lower speed than the Lissajous technique. Three-dimensional imagery using a laser scanner has the major advantage of creating high resolution images of the object under inspection. Images of more than 4000 points x 4000 points are easily acquired Figure 8 illustrates the raster-type acquisition mode, similar to conventional video cameras except that 3-D range information and intensity, in perfect registration, are obtained for all the points scanned in the image. Resolution is also higher than with conventional CCD cameras, as discussed previously. It is usually assumed that an object is relatively stationary with respect to the scanner.

Figure 10 shows a 3-D raster image of a copy of the CTA testing module used during testing of the SVS system on board Space Shuttle Flight STS-52. It is used here for evaluation of geometrical tracking algorithms. Other scanning methods have also been proposed based on the random access laser scanner discussed here.<sup>10</sup>

### Conclusion

Real-time tracking of targets on an object and acquisition of high-density three-dimensional images have been demonstrated using a random access 3-D laser scanner. The prototype has the potential of automatically tracking, in three dimensions, either geometrical features of the object itself or targets attached to it. Excellent immunity to ambient illumination and sun interference is obtained.

Real-time tracking of targets on an object is realized using Lissajous-type scanning patterns or raster type images, depending on the speed of the moving object.



**Figure 11:** Raster type image of a model of the CTA used during space shuttle flight STS-52: (top) intensity image, (middle) range image encoded in grey levels, (bottom) pseudo shaded (derivative) of the range image (texture).

The Lissajous scanning figures give high pointing resolution, excellent stability, and good object position refresh rate.

Tracking error feedback is simultaneously obtained from three different sources: (1) direct tracking error based on each individual targets, (2) global predicted target position based on the calculated estimate of the object position, and (3) external feedback control from the human operator. Tracking of multiple targets using Lissajous patterns is based on user defined scanning

strategies pre-programmed in the laser scanner according to the application requirements.

Angular tracking resolution of 20 arcsec RMS at 150 ft, for a field of view of 30° was measured (1/15000). A more complete study of the calibration parameters and of temperature variations on the laser scanner is still required to fully characterize the exact performance of the sensor. To obtain an absolute accuracy measure for the full working volume (16000 yd<sup>3</sup>), the difficult problem of obtaining a reference system more accurate than the laser scanner must be solved. Only resolution is quoted for the moment. Full calibration of the laser scanner/ASVS system combination is currently in progress.

### References

- [1] S.G. MacLean, M. Rioux, F. Blais, J. Grodski, P. Milgram, H.F.L. Pinkney, B.A. Aikenhead, "Vision System Development in a Space Simulation Laboratory", in *Close-Range Photogrammetry Meets Machine Vision*, *Proc. SPIE 1394*, 8-15 (1990).
- [2] H.F.L. Pinkney, "Theory and Development of an on-line 30 Hz Video Photogrammetry System for Real-time 3-Dimensional Control", *Proceedings of the International Society of Photogrammetry Symposium on Photogrammetry Industry*, Stockholm, 1978.
- [3] F. Blais, M. Rioux, S.G. MacLean, "Intelligent, Variable Resolution Laser Scanner for the Space Vision System", in *Acquisition, Tracking, and Pointing V*, *Proc. SPIE 1482*, 473-479 (1991).
- [4] F. Blais, J.-A. Beraldin, M. Rioux, R.A. Couvillon, S.G. MacLean, "Development of a Real-time Tracking Laser Range Scanner for Space Applications", *Proceedings Workshop on Computer Vision for Space Applications*, Antibes, France, 1993.
- [5] M. Rioux, "Laser Range Finder Based on Synchronized Scanners", *Appl. Opt.*, 23(21), 3837-3844 (1984).
- [6] J.-A. Beraldin, M. Rioux, F. Blais, G. Godin, R. Baribeau, "Model-based Calibration of a Range Camera", *Proceedings IAPR*, The Hague, Netherlands, 1992.
- [7] J.A. Beraldin, S.F. El-Hakin, L. Cournoyer, "Practical Range Camera Calibration", in *Videometrics II*, *Proc. SPIE 2067*, 21-31 (1993).
- [8] F. Blais, M. Rioux, J.A. Beraldin, "Practical Considerations for a Design of a High Precision 3-D Laser Scanner System", in *Optomechanical and Electro-Optical Design of Industrial Systems*, *Proc. SPIE 959*, 225-246 (1988).
- [9] S.J. Orfanadis, "Optimum Signal Processing: An Introduction", *Macmillan Publishing Company*, 2nd Edition, 1985.
- [10] Liu Y., Laurendeau D., "Processing of a Multi-scale Triangulated Surface Model of a 3-D Scene for a Robotics Application", in *Geometric Methods in Computer Vision II*, *Proc. SPIE 2031*, 392-403 (1993).

1. S.G. MacLean, M. Rioux, F. Blais, J. Grodski, P. Milgram, H.F.L. Pinkney, B.A. Aikenhead, "Vision System Development in a Space Simulation Laboratory", in Close-Range Photogrammetry Meets Machine Vision, *Proc. SPIE 1394*, 8-15 (1990).
2. H.F.L. Pinkney, "Theory and Development of an on-line 30 Hz Video Photogrammetry System for Real-time 3-Dimensional Control", *Proceedings of the International Society of Photogrammetry Symposium on Photogrammetry Industry*, Stockholm, 1978.
3. F. Blais, M. Rioux, S.G. MacLean, "Intelligent, Variable Resolution Laser Scanner for the Space Vision System", in Acquisition, Tracking, and Pointing V, *Proc. SPIE 1482*, 473-479 (1991).
4. F. Blais, J.-A. Beraldin, M. Rioux, R.A. Couvillon, S.G. MacLean, "Development of a Real-time Tracking Laser Range Scanner for Space Applications", *Proceedings Workshop on Computer Vision for Space Applications*, Antibes, France, 1993.
5. M. Rioux, "Laser Range Finder Based on Synchronized Scanners", *Appl. Opt.*, 23(21), 3837-3844 (1984)
6. J.-A. Beraldin, M. Rioux, F. Blais, G. Godin, R. Baribeau, "Model-based Calibration of a Range Camera", *Proceedings IAPR*, The Hague, Netherlands, 1992.
7. J.A. Beraldin, S.F. El-Hakin, L. Cournoyer, "Practical Range Camera Calibration", in Videometrics II, *Proc. SPIE 2067*, 21-31 (1993)
8. F. Blais, M. Rioux, J.A. Beraldin, "Practical Considerations for a Design of a High Precision 3-D Laser Scanner System", in Optomechanical and Electro-Optical Design of Industrial Systems, *Proc. SPIE 959*, 225-246 (1988).
9. S.J. Orfanadis, "Optimum Signal Processing: An Introduction", *Macmillan Publishing Company, 2nd Edition*, 1985.
10. Liu Y., Laurendeau D., "Processing of a Multi-scale Triangulated Surface Model of a 3-D Scene for a Robotics Application", in Geometric Methods in Computer Vision II, *Proc. SPIE 2031*, 392-403 (1993).